

SHIMANO '91
BICYCLE
SYSTEM
COMPONENT

DEALERS' PRODUCT MANUAL

Getting Closer to the Cyclist

Shimano is refining the bicycle in a way that significantly improves our ability to move faster, farther, and with greater ease under our own power. Shimano continues to pursue advanced concepts in human engineering in order to better interface the cyclist and the bicycle.

One example is Biopace, a computer-designed chainring that improves pedaling efficiency and comfort. The revolutionary Shimano Index System (SIS) lets virtually anybody shift the bicycle's derailleur easily and accurately without practice or experience. Shimano Linear Response brakes provide a new level of braking control. Computer-designed HG sprockets and Shimano SG chainrings enhance SIS shifting. Shimano Pedaling Dynamics (SPD) is the first shoe-pedal interface that achieves clipless pedaling performance from a walkable hiking-type shoe.

These advanced functions stand behind Shimano Total Integration, a breakthrough bicycle control system which allows the cyclist to steer, shift gears, and brake from one unchanging hand position. With Shimano Total Integration, safety, efficiency, and performance are simultaneously enhanced—the ultimate goal of human engineering.

These are the ways in which Shimano is bringing the bicycle closer to the cyclist.

It's the end result of a design philosophy based on creating the most ergonomically efficient relationship between the man and the machine.

1	The Shimano Total Integration Concept
3	Advanced Features
11	Freehub/HG Gear/Freewheel Interchangeability
13	Road Component Groups
15	Dura-Ace
25	Dura-Ace Track
27	Shimano 600 Ultegra
33	Shimano 105SC
39	Shimano RX100
41	Exage EX
45	Nexus
47	Off-Road Component Groups
49	Shimano Deore XT
57	Shimano Deore DX
63	Shimano Deore LX
69	Exage LX
73	Shimano GS
76	Tourney
77	The SPD Concept
78	SPD Functions
79	Shimano Cycling Footwear
82	Small Parts & Tools

SMALL PARTS/TOOLS



SHIMANO
TOTAL
INTEGRATION



The Shimano Total Integration
Concept

Now you can steer, brake, and shift gears without ever taking your hands off of the handlebars.

Traditionally, racing bicycles and many light weight sport bikes used downtube shift levers that force you to let go of the handlebar in order to shift. This makes it difficult to shift while braking, cornering, or climbing without losing speed and balance. But there are times when being able to shift gears during these maneuvers can result in a real advantage—whether riding in competition or not.

The conventional off-road bicycle has its shift lever mounted on top of the handlebar, a position which forces the rider to change or loosen the grip on the bar in order to shift. This results in a certain amount of instability, loss of speed, and diverted attention when shifting.

Shimano took on the challenge of developing a more “rider friendly” bicycle control system that would allow the cyclist to freely apply the brakes and shift gears during any cycling maneuver.

That system is Shimano Total Integration. Shimano Total Integration combines the advanced functions of SIS, HG sprockets, Shimano SG chainrings, and SLR brakes. The result is a dramatic improvement in bicycle control from being able to shift and brake from one hand position. This means you can shift while cornering, climbing, and even while sprinting out of the saddle—without losing speed, balance, or concentration.

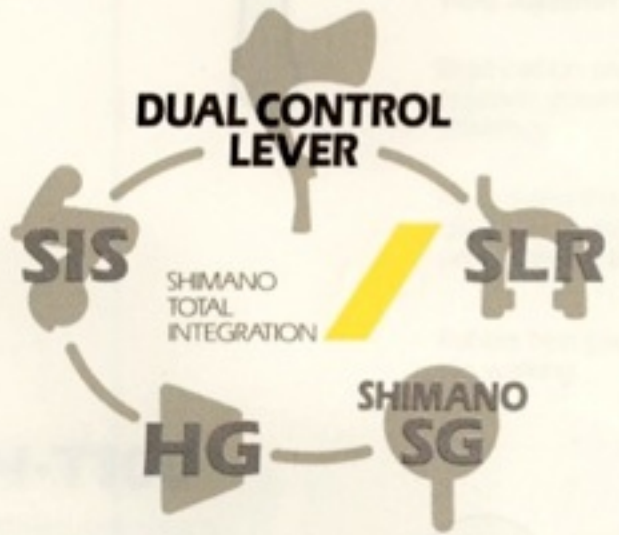

Shimano Total Integration redefines the racing bicycle.

●Just what is the "dual control lever?"

The dual control lever is used for road bike to combine the braking and shifting functions. The brake lever actually has two functions. You apply the brakes in the conventional manner by pulling the lever back. But when you push the brake lever (or main shifting lever) toward the center of the bicycle, you shift the rear derailleur to larger sprocket, or shift the front derailleur to the large chainring.

●How does the dual control lever work?

Just push the dual control lever sideways, toward the center of the bike, to downshift one gear. There's a smaller lever behind it called the "release lever." Push the right side release lever and it "releases" the shift cable, allowing the derailleur to "upshift" to the next higher gear. Push the left side release lever to downshift the front derailleur to the small chainring. Furthermore, the main lever upshifts with a ratchet action, so it always returns to the same position for the next shift.

●What are the benefits for the rider?

The ability to shift quickly and accurately has always been an important factor in bicycle racing. Being in the wrong gear at the wrong time has caused many a rider to lose a race or finish poorly. Shimano Total Integration has eliminated the adverse effect that shifting can have on the performance of a competitive cyclist. With Shimano Total Integration you can...

- ...shift fast and precisely under maximum pedal loads without letting go of the handlebar and without giving up hard-won speed.
- ...punch in the best gear to exit a turn while still cornering in order to save valuable seconds accelerating.
- ...instantly get the best gear when climbing, in or out of the saddle, without releasing the bars and without letting up on pedal speed.
- ...quickly shift into the best gear without letting go of the bars when riding on bad roads.

For the first time, Shimano Total Integration gives the racing cyclist total freedom in gear selection regardless of maneuver, road, or race conditions. Furthermore, it reduces rider indecision, lessens fatigue, and provides a significant competitive advantage for the racing cyclist.

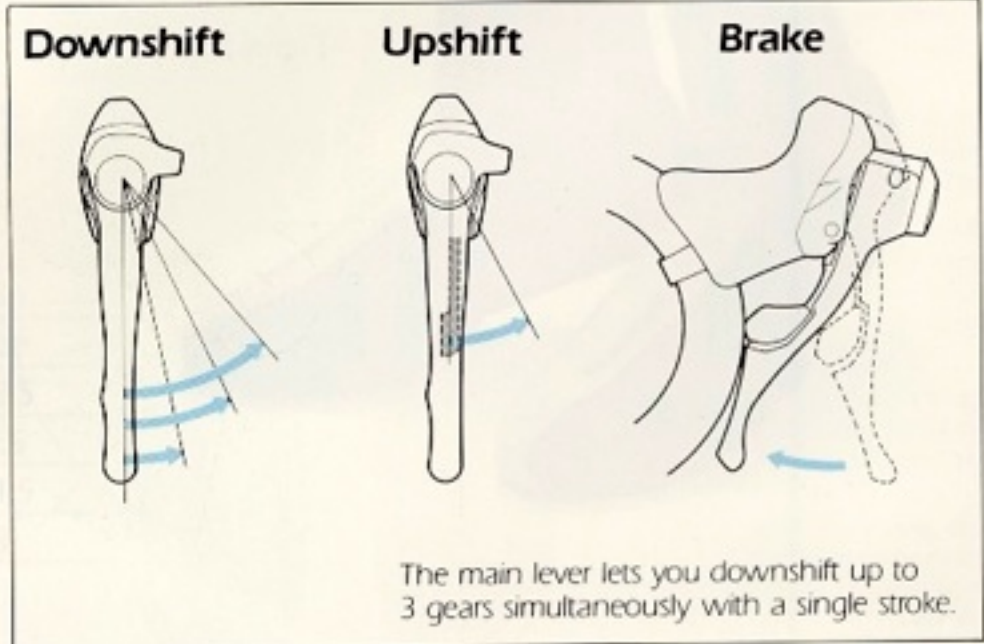
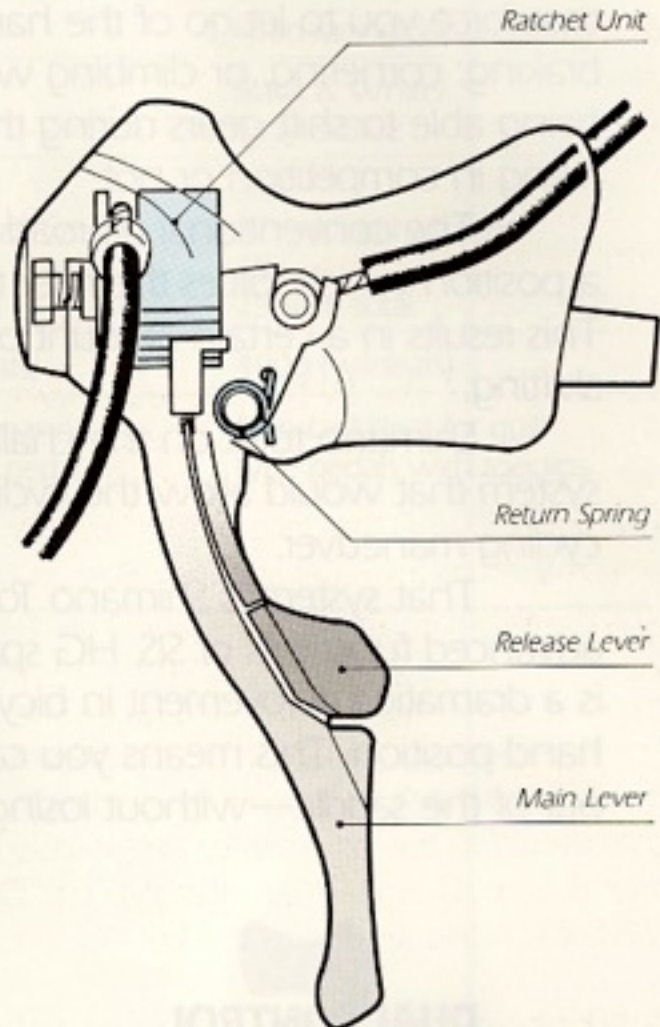

A leading edge function provides a higher level of control for the off-road bicycle.

●Just what is Rapidfire?

Rapidfire is Shimano's new shift lever for off-road bicycles. The Rapidfire shift levers are positioned under the handlebar and in front of the thumb when the hand is in its natural bar-gripping position. The upshift and downshift levers both work with a "push-only" ratchet action. The shifting action is easily executed by the thumb without the need to change hand position on the bar.

RAPIDFIRE

●How does the Rapidfire lever work?

For the rear derailleur, the lower lever is the "main," or "downshift" lever which shifts to a larger sprocket. The upper lever is the "release" or "upshift" lever which shifts to a smaller sprocket. Besides being able to shift one gear at a time, the main lever also lets you shift the full gear range, from the smallest sprocket to the largest, with one quick 90° stroke. The Rapidfire front derailleur shift lever lets you shift triple chainwheels one at a time, or directly from the smallest chainwheel to the largest with an extended push on the lever (Deore XT and DX levers only). The Dual Repeat Mechanism always returns the lever to the same position.

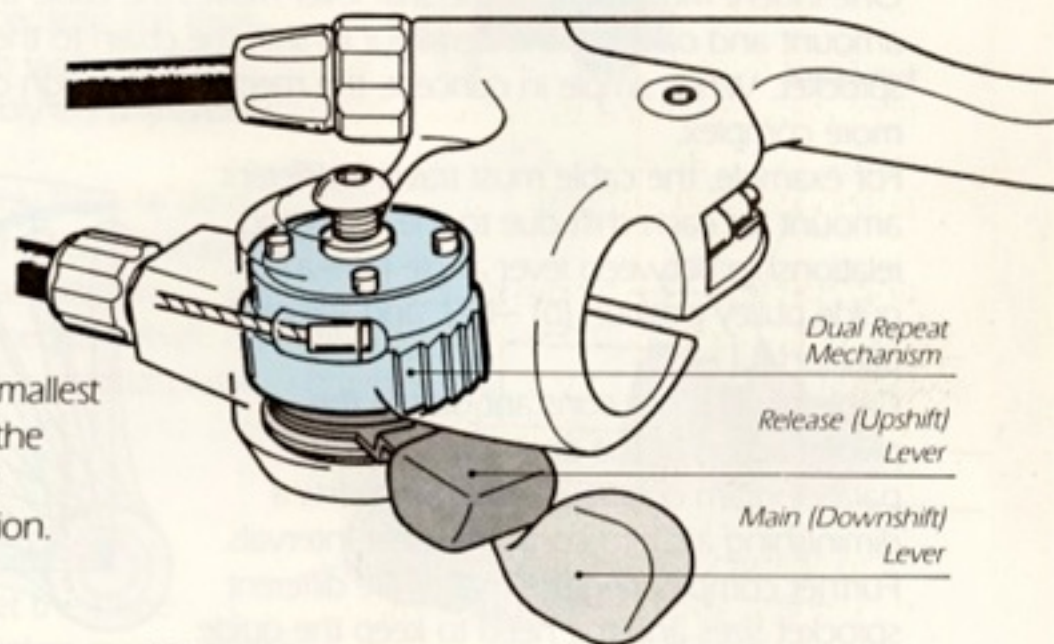

●What are the benefits for the rider?

The advantage of Rapidfire is that it allows you to shift gears quickly and accurately without sacrificing control or diverting attention from terrain ahead. You can shift and brake whenever you want, in the middle of any maneuver, without ever loosening your grip on the bar. The overall result is an off-road cycling experience with a greater feeling of confidence and control. Rapidfire also lets you more easily achieve a higher level of cycling performance because you can finally concentrate on riding—not shifting.

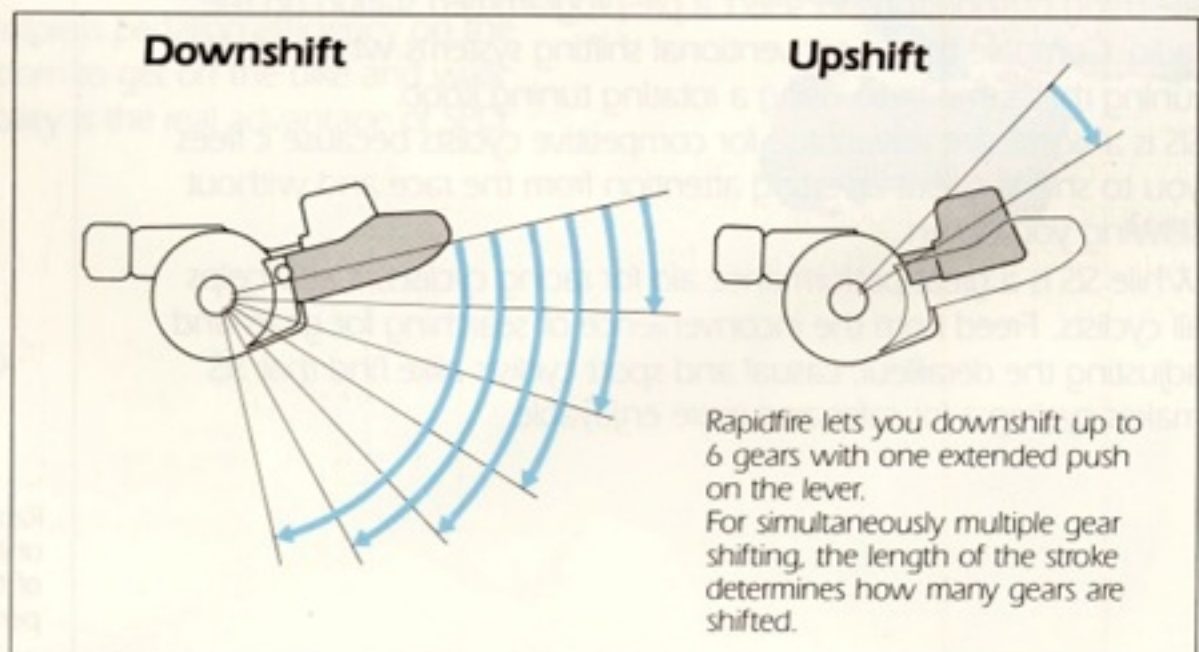



The indexed shifting system that continues to define the state of the art.

●Just what is the Shimano Index System?

The Shimano Index System takes the guesswork out of derailleur shifting by using a shift lever that guides you to the next gear with a built-in indent action. Once the shift lever is moved by the rider, it automatically falls into the next indexed position to complete the shift. There is no need to "adjust" or "trim" the derailleur. SIS does it all for you.

●How does SIS work?

SIS utilizes a ratchet action indexing unit installed inside the lever body. One indent movement of the shift lever moves the cable a specified amount and operates the derailleur to shift the chain to the next sprocket. While simple in concept, the mechanical design of SIS is more complex.

For example, the cable must travel a different amount for each shift due to the changing relationship between lever angle ($a_1 \sim a_7$), guide pulley position ($b_1 \sim b_7$), and sprocket position ($L_1 \sim L_8$).

Cable travel is not constant due to the pivotal action of the dual-pivot parallelogram derailleur which converts a diminishing arc into constant linear intervals. Further complicating the matter are different sprocket sizes and the need to keep the guide pulley as close as possible to each sprocket as it traverses the cluster. The heart of SIS is the indexing unit in the shift lever which must compensate for the changing geometry of the rear derailleur at each shift point.

●What are the benefits to the rider?

With SIS, shifting performance no longer depends on the skill of the rider to manipulating the shift lever. SIS makes derailleur shifting just like using pushbuttons to select a pre-programmed station on the radio. Compare this to conventional shifting systems which are like tuning that same radio using a rotating tuning knob.

SIS is a significant advantage for competitive cyclists because it frees you to shift without diverting attention from the race and without slowing you down.

While SIS is a great performance aid for racing cyclists, it also helps all cyclists. Freed from the inconvenience of searching for gears and adjusting the derailleur, casual and sport cyclists alike find that SIS makes cycling a lot safer and more enjoyable.

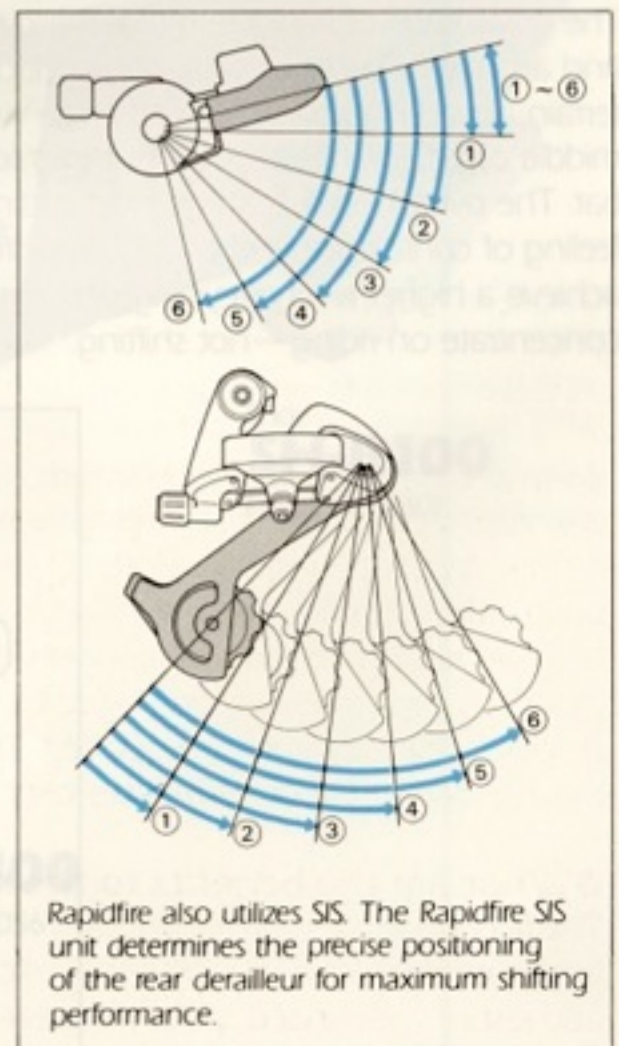
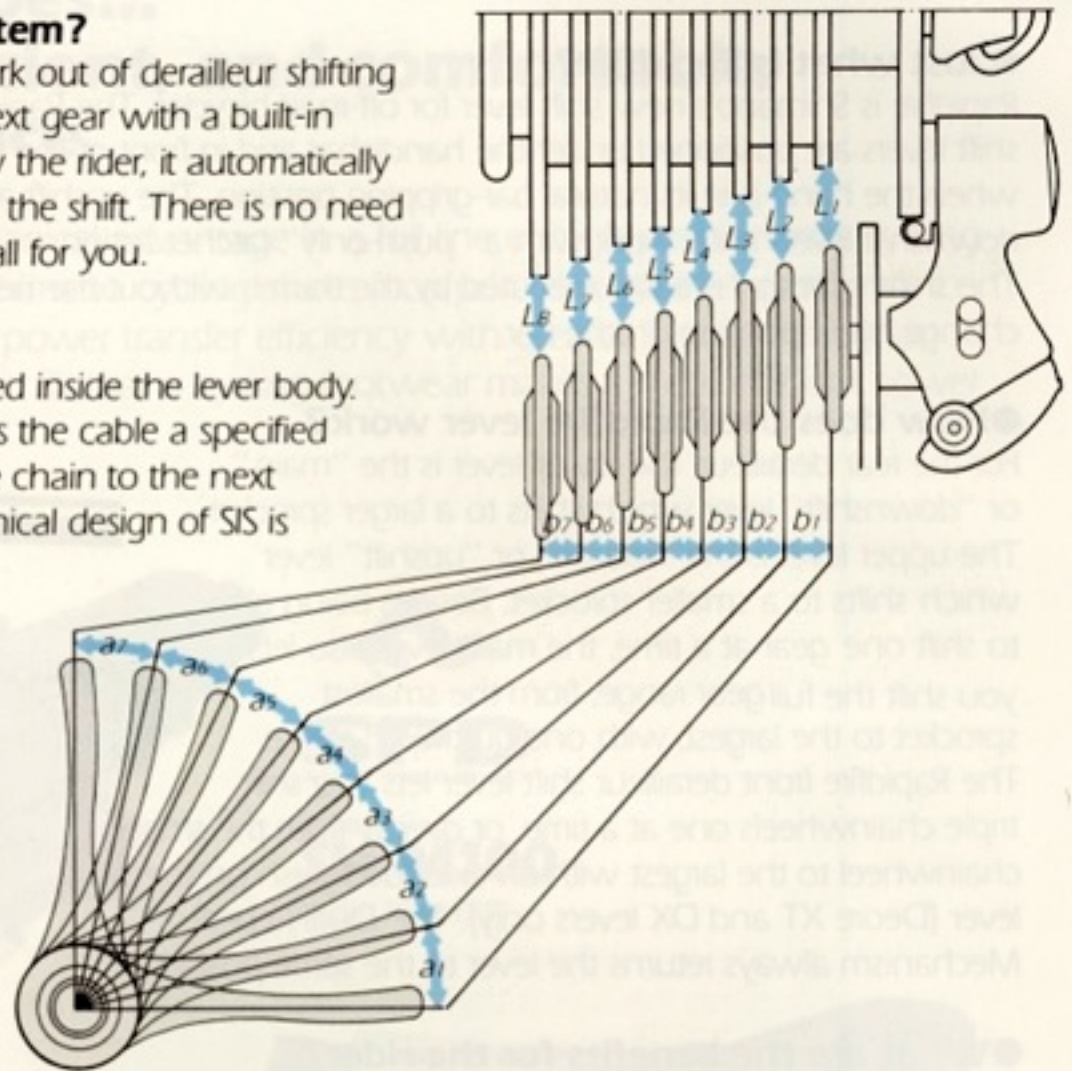

Rapidfire also utilizes SIS. The Rapidfire SIS unit determines the precise positioning of the rear derailleur for maximum shifting performance.

HG

Smoother shifting under any pedaling condition.

●Just what are HG sprockets?

HG sprockets have been computer-designed to upgrade SIS shifting performance through smoother, faster, and more positive chain transfer between cogs on the freewheel. Strategic sprocket positioning and special profiling guide the chain directly from cog to cog with minimal override and no slipping.

●How do the HG sprockets work?

When shifting gears with conventional sprockets, the chain rides on top of the sprocket teeth and sometimes slides over the teeth before fully engaging. This slows down chain transfer between the sprockets and results in sloppy, imprecise shifts.

HG gears use specially shaped teeth and indexed sprocket positioning determined by computer. This allows the chain to move directly from one cog to the next without override and without slipping. Specified chain release and pickup points on the sprockets assure that the chain shifts quickly from one sprocket to the next only at the designated shift points.

●What are the benefits for the rider?

The main advantage of HG sprockets is quick and precise shift under any pedaling load. In other words, gears can be changed quickly and accurately without letting up on pedal pressure and shifting balance. This means that you don't have to synchronize the shift with a release of pedal pressure. HG sprockets realize fast and smooth shifts that are not affected by chain tension.

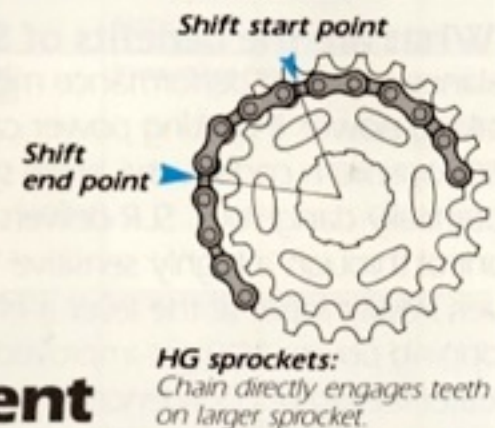
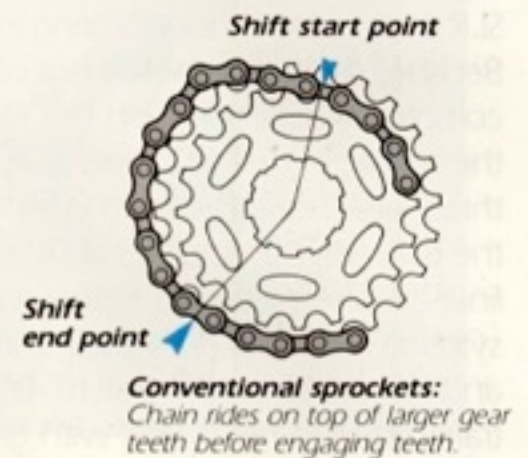
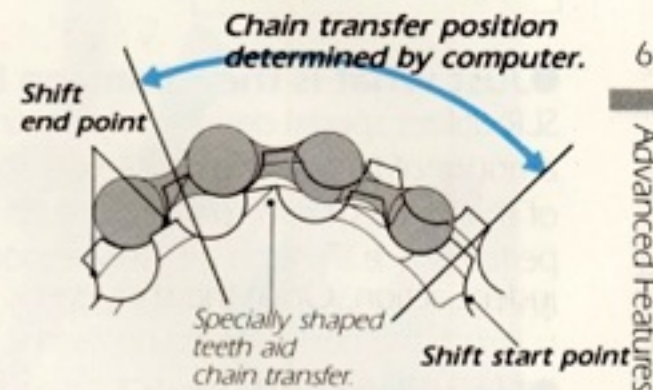

THE SHIMANO FREEHUB

A significant improvement of rear hub design.

●Just what is the freehub?

The freehub integrates the rear hub and freewheel mechanism into a single unit design. Cassette sprockets slip on and off the splined freehub for fast and easy gear changes.

●How does the freehub work?

Besides integrating the hub body and freewheel into a single unit, the freehub features "unibalanced" design which helps to reduce rim offset, often called "rear wheel dish". With reduced dish, spoke tensioning can be more uniform to make a stronger wheel. In addition, freehub design allows the right side hub bearing to be positioned closer to the right dropout where the axle is supported. This greatly reduces the load on the axle and just about eliminates bent axles.

●What are the benefits to the rider?

The freehub is the heart of a stronger and better performing rear wheel which contributes to cycling performance and safety. A freehub wheel also results in extended spoke life, greater stiffness, and increased power transmission efficiency. Furthermore, Shimano offers an 8-speed freehub which does not increase the amount of dish over 7-speed types.

Compare the difference in rim offset

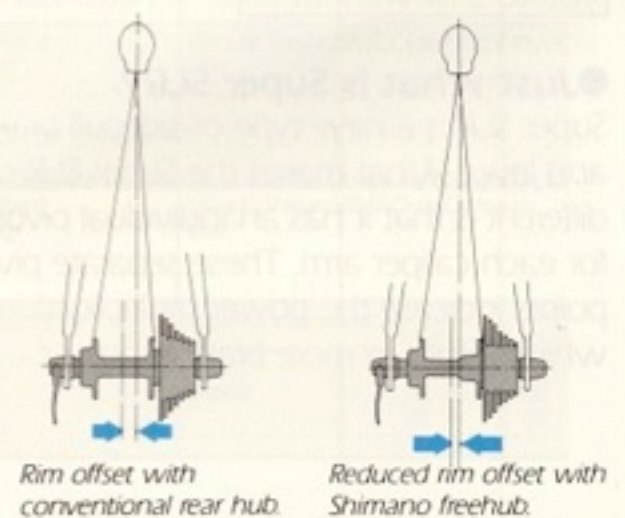



Increased braking power with a more sensitive feeling of control.

● Just what is the "Shimano Linear Response?"

SLR utilizes special designs which eliminate a significant amount of friction from the levers, cables, and calipers of the brake system. The result is upgraded braking performance through a highly responsive lever feeling and strong, easily modulate stopping power.

● How does SLR work?

SLR uses a return helper spring in the brake lever itself. Because the return movement of the lever action is not completely dependent on the strength of the spring at the caliper, a weaker caliper spring can be used. A thrust bearing and coated washer are used between the caliper arms, and a brake cable with a low-friction liner are also utilized to further reduce friction in the system. The result is a lighter and lively lever feeling and a more balanced system. Braking power is more efficiently transmitted to the wheel with greater feedback returned to the lever.

● What are the benefits of SLR to the rider?

Balanced braking performance means a lot more than just strong braking power. If braking power cannot be effectively applied with optimum control, the brake system is inefficient and potentially dangerous. SLR delivers a higher level of braking control through a highly sensitive "linear response" feeling at the lever. Power input at the lever is efficiently converted into bike stopping power. You get improved stopping performance and a greater feeling of confidence in your ability to control the brakes. Racing cyclists use SLR to dive deeper into turns before braking and to finely control descending speeds. Sport and casual cyclists ride with more confidence and enjoyment knowing that the brakes will always respond predictably.

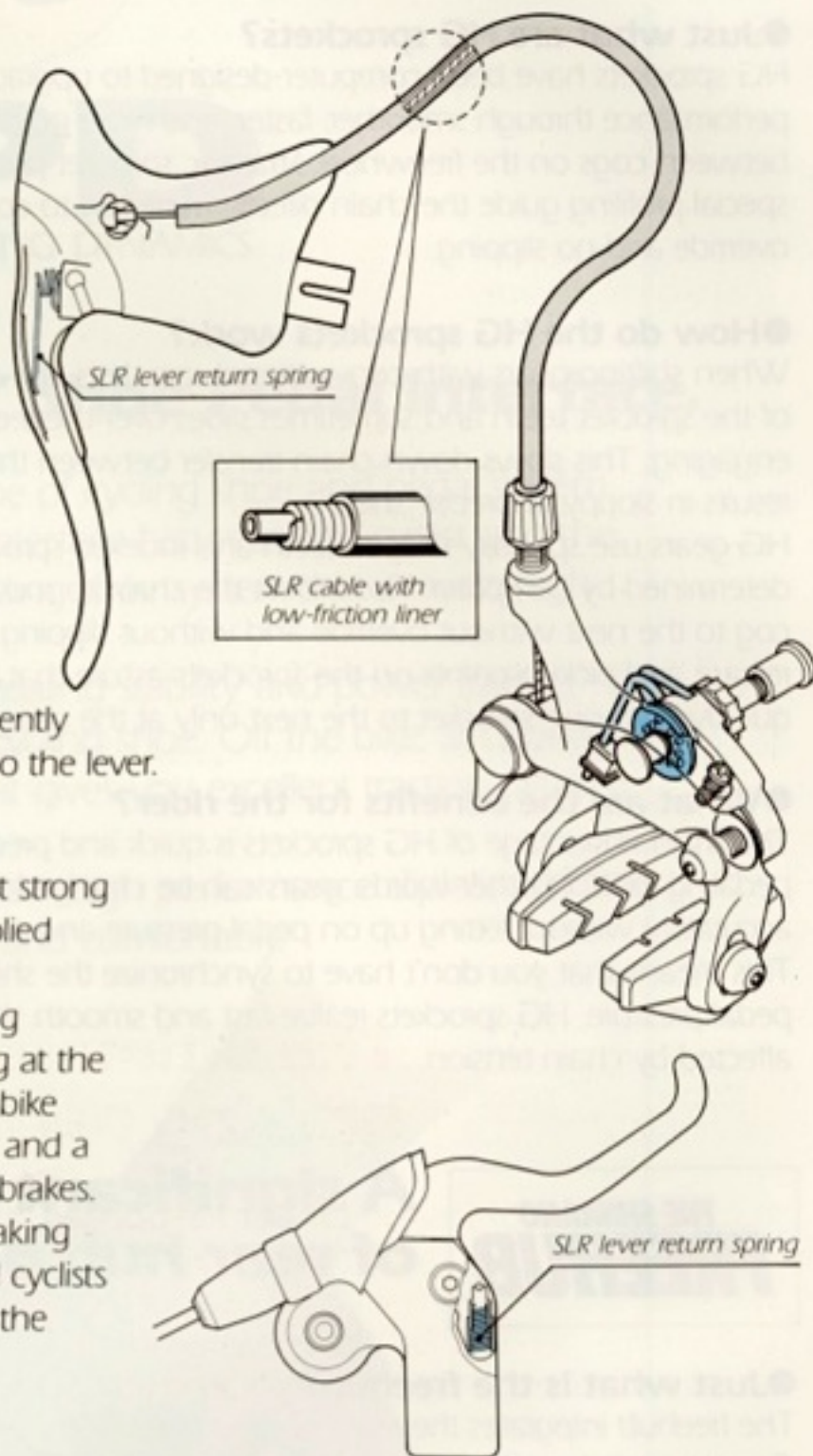

Super SLR enhances the braking power of Shimano Linear Response.

● Just what is Super SLR?

Super SLR is a new type of sidepull brake caliper and lever. What makes the Super SLR caliper different is that it has an individual pivot point for each caliper arm. These separate pivot points increase the power multiplication factor which results in more braking power.

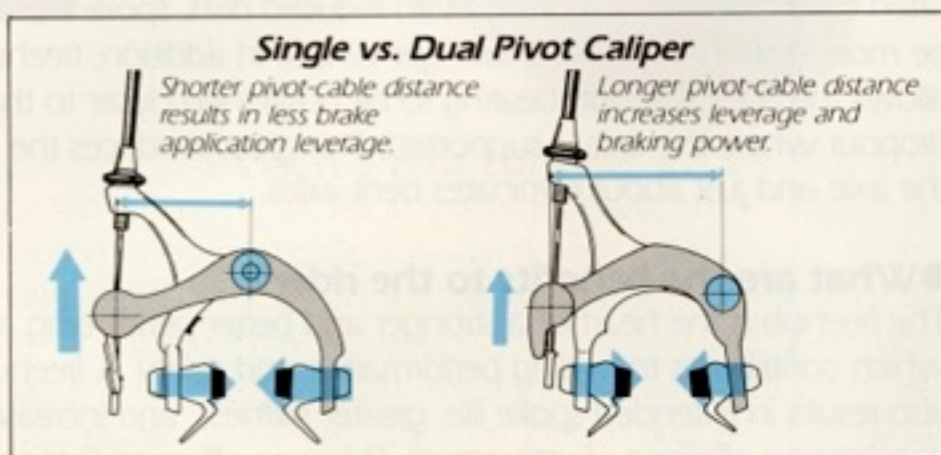

●How does Super SLR work?

The main parts of the sidepull caliper are the "Y" arm and the "C" arm (named for their basic shape). With conventional brakes, both arms pivot on the same point. The Super SLR caliper, however, gives the "C" arm its own pivot point that's separate from the "Y" arm in order to increase leverage. The result is that the pressure applied to the rim increases in relation to the pressure applied at the lever. Furthermore, the increase in braking leverage at the "C" arm is transferred to the "Y" arm so that the increased leverage is applied equally between the two caliper arms.

The increased power multiplication factor causes the shoes to move a shorter distance in relation to lever travel. To compensate for this shortened caliper movement, the Super SLR brake lever has been designed to provide a 2-phase action. The 1st phase quickly brings the brake shoes into contact with the rim, while the 2nd phase applies increased leverage to enhance braking power.

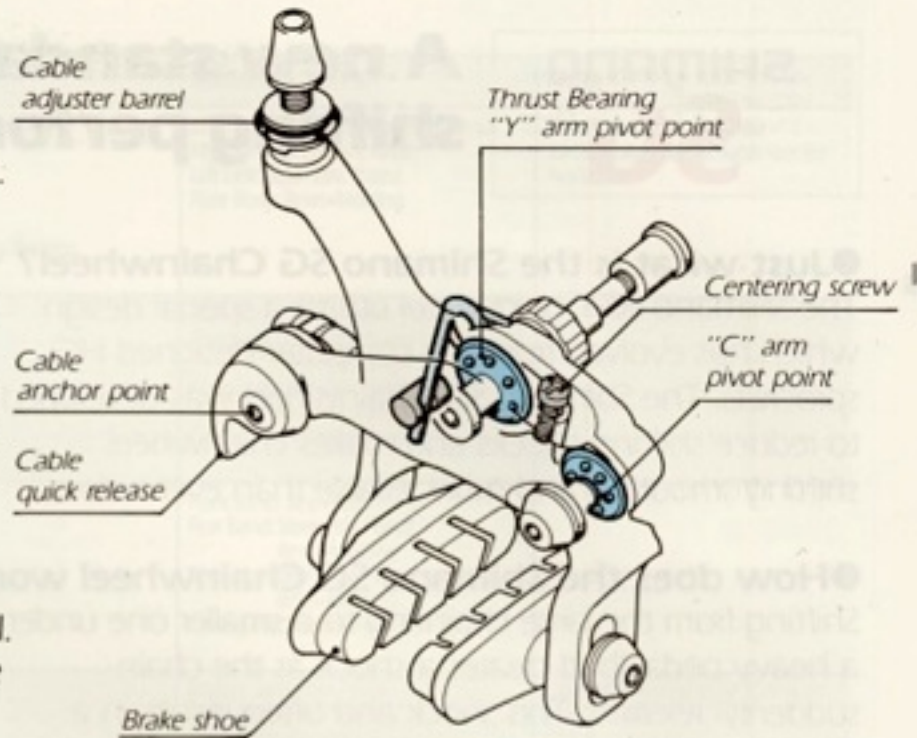

●What are the benefits for the rider?

The benefit of Super SLR is that it provides the cyclist with greater braking power without the need to squeeze the lever harder. Coupled with the highly sensitive SLR mechanism, Super SLR provides even more braking power that can be easily modulated at the lever with a secure feeling of control. Super SLR is a significant improvement in overall braking performance.

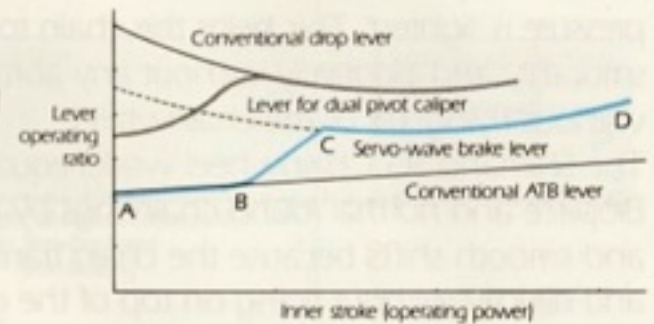

The ultimate in off-road braking performance.

●Just what is Shimano Linear Response Plus?

SLR Plus is a new high performance braking system for the off-road bicycle. The heart of the system is the "servo-wave" brake lever which actually increases the power multiplication advantage as the lever is pulled.

●How does the SLR Plus work?

SLR Plus utilizes a unique cam-type cable holder and servo-wave link. As the lever is pulled, the pivot point of the servo-wave link changes its position in relation to the cable holder. This results in a faster shoe-rim contact time and an increase in lever output when it's really needed—after the brake shoes come into contact with the rim.

●What are the benefits to the rider?

In off-road riding, there are many times when you've got to keep a firm grip on the bars while braking hard. Yet this makes it difficult to steer and use the brakes simultaneously when going over rough terrain. SLR Plus helps reduce fatigue and increase control with a soft modulated lever action. More lever travel is provided in the range where the brakes are in actual contact with the rim. The end result is that it becomes easier to maintain braking power and control, especially over rough terrain.

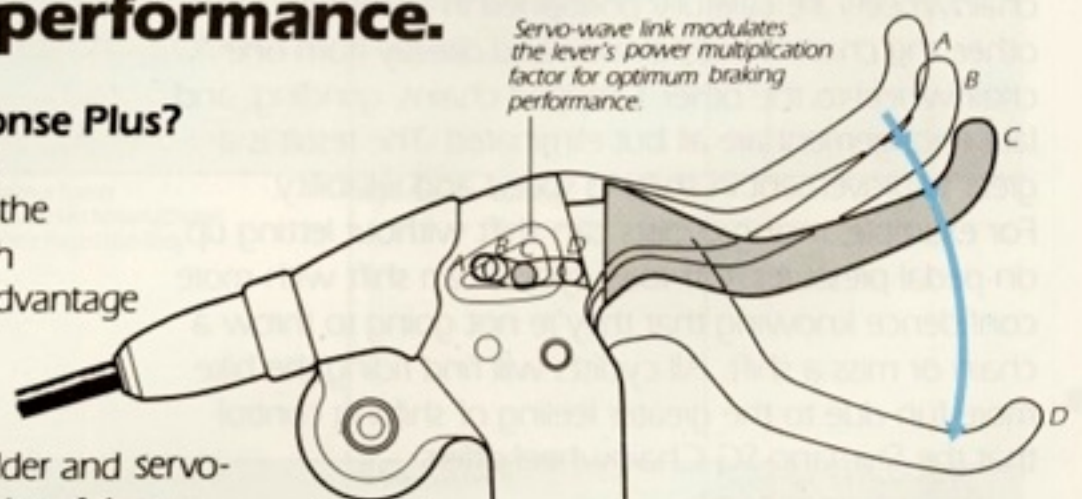

A-B stroke brings shoes quickly into contact with rim. B-C stroke slows cable take-up. C-D stroke increases power multiplication factor for super-strong but easily modulated braking power.

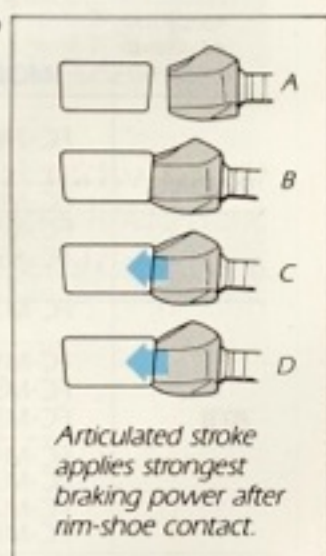

SHIMANO
SG

A new standard in chainwheel shifting performance.

● Just what is the Shimano SG Chainwheel?

The Shimano SG Chainwheel utilizes a special design which has evolved from the computer-designed HG sprockets. The Shimano SG Chainwheel was developed to reduce shifting shocks and makes chainwheel shifting smoother and more reliable than ever before.

● How does the Shimano SG Chainwheel work?

Shifting from the large chainring to a smaller one under a heavy pedal load creates a shock as the chain suddenly releases. This shock often results in a thrown chain or a messy grinding shift onto the small chainring. The Shimano SG Chainwheel solves this problem by using special chain release and pickup teeth at the two points on the chainwheel where pedal pressure is lightest. This helps the chain to transfer smoothly and positively without any abrupt shocks and without flying off of the chainwheel.

The Shimano SG Chainwheel works equally well on Biopace and normal round chainrings by promoting fast and smooth shifts because the chain transfers quickly and directly without riding on top of the gear teeth.

● What are the benefits for the rider?

Because the pickup and release points on the chainwheels are carefully positioned in relation to each other, the chain moves quickly and directly from one chainwheel to the other. Dropped chains, grinding, and late engagement are all but eliminated. The result is a great improvement in shifting speed and reliability. For example, racing cyclists can shift without letting up on pedal pressures. Off-road cyclists can shift with more confidence knowing that they're not going to throw a chain or miss a shift. All cyclists will find riding the bike more fun due to the greater feeling of shifting control that the Shimano SG Chainwheel offers.

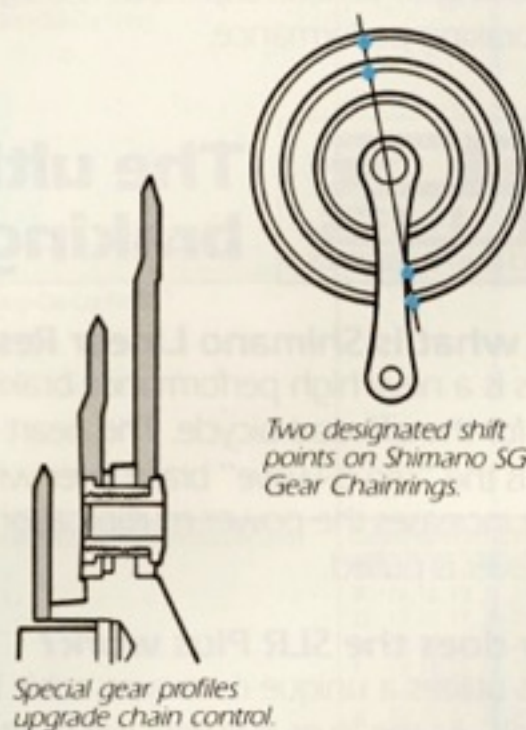
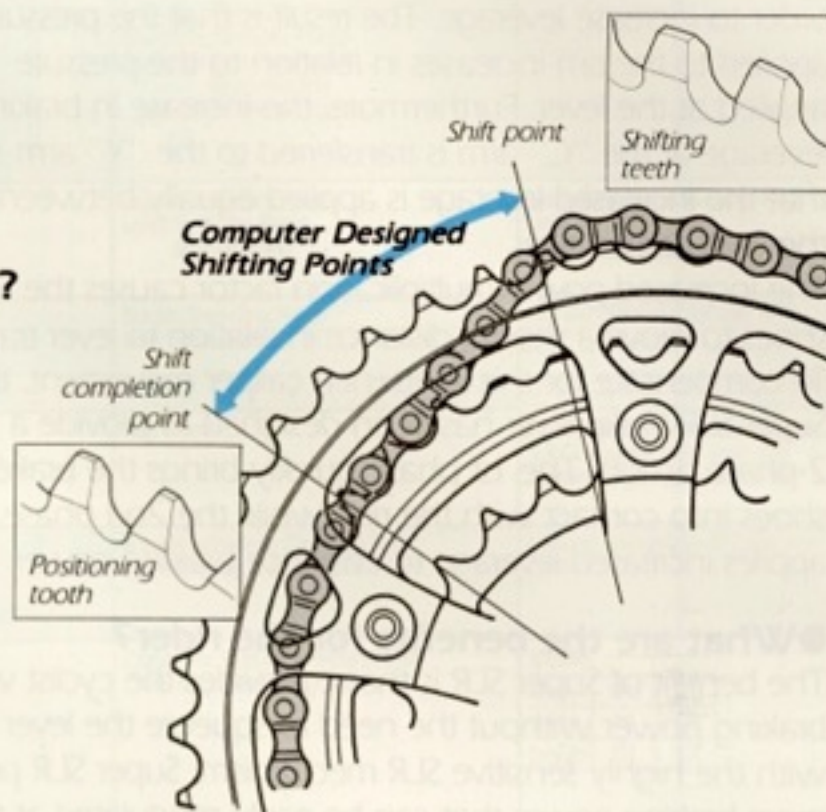

	MODEL	BIO-PACE SG	ROUND SG
RACING	FC-7402-SG	—	*A-53 x 42 *A-52 x 42 *B-53 x 39
	FC-6400-SG FC-1055 FC-A550	52 x 42	53 x 42 52 x 42
	FC-M730-SG	48 x 38 x 28 46 x 36 x 26	48 x 38 x 28 46 x 36 x 24
ATB	FC-MT60-SG FC-M550 FC-M500	48 x 38 x 28 46 x 36 x 26	48 x 38 x 28 46 x 36 x 24
	FC-M400 FC-M300 FC-M200 FC-M100	48 x 38 x 28	—

*If the inner is 42, A-53 or A-52 should be used for the outer;
if the inner is 39, B-53 should be used for the outer.

Creating a more rider-friendly pedaling action.

● Just what is Biopace?

Traditional round chainrings force the leg to maintain a constant pedaling cadence. This actually fights the leg's natural tendency to change speed during the pedaling motion. Biopace is a non-round chainwheel which has been ergonomically designed to create a more natural pedaling cadence that takes into account the normal changes of the leg when pedaling.

● How does Biopace work?

The Biopace concept was born when Shimano used a computer to analyze the pedaling motion with a round chainring. Computer analysis demonstrated that leg power was not being efficiently utilized. With the computer's help, Shimano found that a round chainring forces the leg to conform to a constant rotational speed. This fights the natural tendency of the leg to slow down at the top and bottom of the pedal stroke as it does when walking or running. It became apparent that a variable-speed pedaling cadence in harmony with the natural speed changes of the leg would be a more efficient way to pedal.

Biopace does exactly this. The special shape of the Biopace chainring increases the chainwheel radius to slow down the leg at the top and bottom of the pedal stroke. The radius is decreased and the down and upstroke phases of the pedaling cycle to help the leg move faster. In this way, Biopace creates a more natural pedaling movement.

● What are the benefits for the rider?

Because the Biopace chainwheel uses energy more efficiently, you can ride farther with less fatigue. Computer calculations disclosed that a Biopace chainring can actually reduce energy demands up to 3 percent for a given distance.

Besides saving energy and increasing stamina, Biopace reduces stress on the knees and makes for a more comfortable pedaling feeling. Biopace chainrings are also available in performance versions designed for the faster pedaling cadences of performance oriented cyclists.

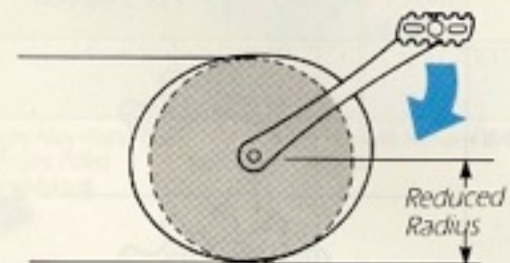

Chainwheel radius is reduced during the downstroke.

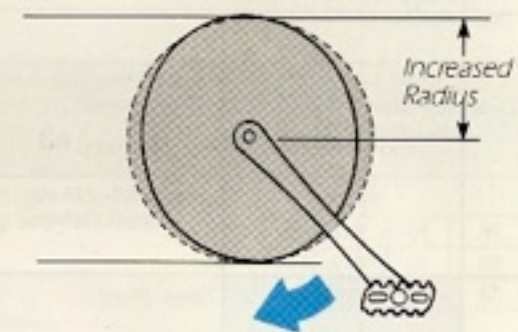

Chainwheel radius is increased during the upstroke.

Individual designed chainrings according to function

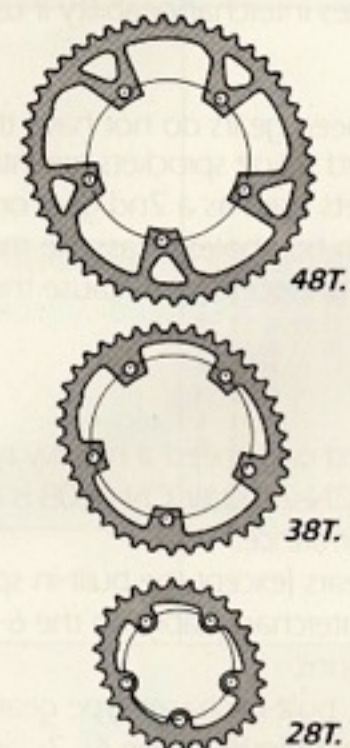

THE SHIMANO FREEHUB SYSTEM

Greater Interchangeability Among the Freehubs

Series	DURA-ACE/Champagne			600 ULTEGRA/Silver	600EX/Silver	Standard/Black
Model No.	CS-7400-8	CS-7400-7	CS-7400-6	CS-6400-7	CS-6400-6	CS-1000
	For 8-speed	For 7-speed	For 6-speed	For 7-speed	For 6-speed	For 6-speed
Top Gear (threaded gear)						
Built-In Spacer Type Second Gear						
Other Spline Gears (including flat type second gear)						
Sprocket Spacer A	No Need *3	No Need *3	No Need	Resin: Dark gray 3.3mm For second gear *Sprocket spacer A is unnecessary if a 13-teeth sprocket is used.	Steel *Sprocket spacer A is unnecessary if a 12-teeth sprocket is used.	 For top gear
Sprocket Spacer B	Aluminum Silver 3.0mm 	Steel: Silver 3.1mm 	Steel: Gray 3.65mm 	Resin: Dark gray 3.15mm For third gear-low gear	Resin: Light gray 3.7mm For second gear-low gear *Sprocket spacer B is unnecessary if a 13-teeth sprocket is used.	 For second gear-low gear
Sprocket Fixing Bolt		No Need		 21.5mm	 23.2mm	

↔ Denotes interchangeability.

→ Denotes interchangeability if used without sprocket cassette through-bolt.

- *Some 6-speed gears do not have the 6S mark. Some 7-speed and 8-speed gears have only the 7S mark.
- *1: Standard spline sprockets are interchangeable with Dura-Ace but do not have the high-performance tooth profile.
- *2: Sprockets used as a 2nd gear on a 6-speed freehub, or a 3rd gear on a 7-speed freehub, must have cassette-type through-bolt holes if cassette mounting is desired.
- *3: Spacer unnecessary because the 2nd gear is a built-in spacer type.

Notes:

- For 7-speed or 8-speed a narrow type chain is required. Shimano CN-7400 or CN-6208 is recommended for best performance.
- Splined gears (except the built-in spacer type gears) can be used interchangeably on the 6-, 7-, and 8-speed combinations.
- Top gears, built-in spacer type gears, and sprocket spacers are unique for the 6-, 7-, and 8-speed combinations and are not interchangeable.
- The thread dimensions of the Dura-Ace top gear (screw-on type) are different from other top gear sprockets.
- Due to their asymmetrical spline, Hyperglide sprockets are not interchangeable with non-Hyperglide freehubs. Use designated chain with Hyperglide cassette.

HG CASSETTE SPROCKET SYSTEM

CS-7401

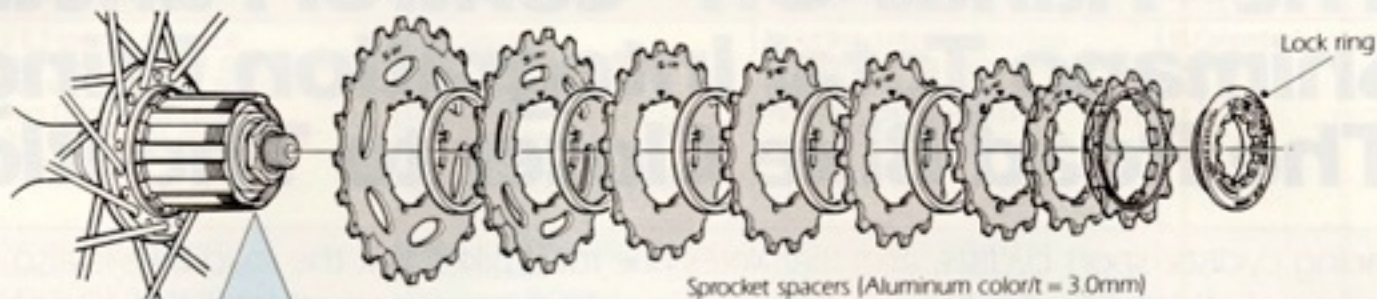

For each sprocket, the surface that has the group mark should face outward and positioned so that the triangle (▲) mark on each sprocket and the A part (where the groove width is wide) of the freewheel are aligned.

The groove width is wide at one place only.

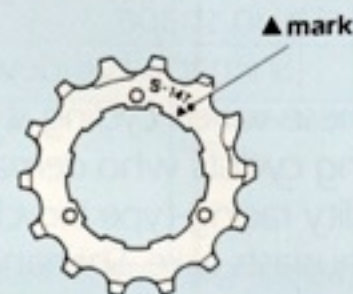
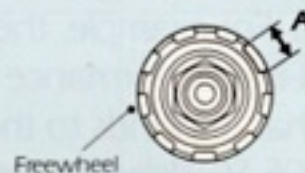

CS-HG90
CS-HG70
CS-HG50

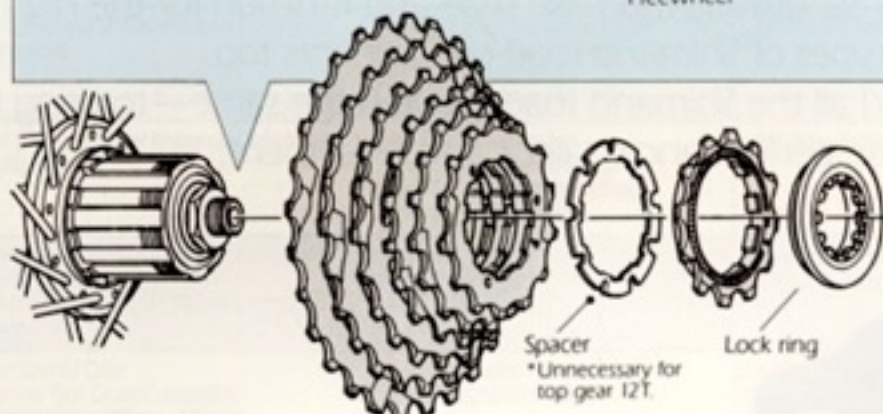

Model No.	Group mark	Combination
CS-7401	S	12, 13, 14, 15, 16, 17, 19, 21T.
	T	13, 14, 15, 16, 17, 19, 21, 23T.
	U	12, 13, 14, 15, 17, 19, 21, 23T.
CS-HG90 CS-HG70 CS-HG50	E	12, 14, 16, 18, 21, 24, 28T.
	F	14, 16, 18, 21, 24, 28, 32T.
	G	13, 15, 17, 20, 23, 26, 30T.
	H	13, 15, 17, 19, 21, 23, 26T.
	I	13, 14, 15, 17, 19, 21, 23T.
	J	13, 14, 15, 16, 17, 19, 21T.
CS-HG50	K	13, 15, 17, 20, 24, 29, 34T.
	L	12, 13, 14, 15, 17, 19, 21T.
	M	13, 15, 17, 19, 21, 24, 28T.

Notes

- Always be sure to use the HG sprocket set bearing the same group marking.
- Never use in combination with a sprocket bearing a different group marking.

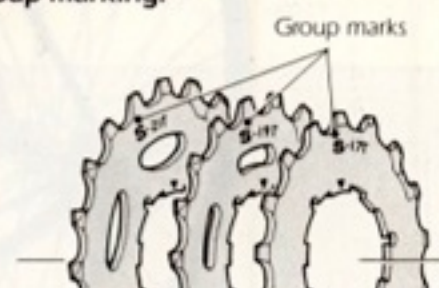

THE SHIMANO FREEWHEEL SYSTEM

Features:

- Splined Design**—All 6-speed freewheels use a thread mounted top gear. The 2nd through 6th gears simply slide on and off for fast and easy replacement. For 7-speed freewheels, the top two sprockets are thread mounted. The 3rd through 7th sprockets are the spline type.
- Uniglide Tooth Profile**—All freewheels incorporate precise-shifting SIS type Uniglide twist-tooth profiles.
- Sealed Mechanisms**—Dura-Ace, Santé, and 600 ULTEGRA freewheels incorporate efficient O-ring sealing for all-weather durability and a long service life.
- Easy Maintenance**—Dura-Ace, Santé, and 600 ULTEGRA freewheels have an oil port on the body that allows internal lubrication of bearings and pawls simply by removing the sprockets (use oil only).
- SIS Precision**—All 6-speed freewheels use the same precise SIS-type sprocket spacing. 7-speed freewheels (Dura-Ace & Santé) utilize the same narrow-type SIS sprocket spacing.

HG Freewheel (MF-HG20)

Sprocket Combinations:

14-24	14, 16, 18, 20, 22, 24T.
14-28	14, 16, 18, 21, 24, 28T.
14-32	14, 17, 20, 24, 28, 32T.

Note: Be sure to use HG Compatible Narrow Chain CN-HG70, CN-HG50.

The "Hands-On" Control Function of Shimano Total Integration Brings The Road Bike Closer to The Rider.

Racing cyclists, sport cyclists, and triathletes ride road bikes. But the road bike is also ridden by a variety of athletes to supplement their training. And many non-athletes ride bikes just to have fun and stay in shape.

Shimano has developed a variety of road component groups that respond to the needs of these varied cycling styles. For example, the Dura-Ace group aims at professional and amateur racing cyclists who demand top performance and durability. The Ultegra group makes possible a quality racing-type bicycle that responds to the needs of amateur racers and performance enthusiasts alike. Shimano 105 SC delivers racer-like style and function for the high-performance sport bicycle. There are other types of Shimano road components too.

But the concept behind all the Shimano road group is the same—to bring the bicycle closer to the cyclist in order to increase performance, safety, and enjoyment.

13
Road Component
Groups



Component Group	Theme & Application	Main Features	User Benefits	New for 1991
DURA-ACE	The top quality road component group for competition.	Features high mechanical precision, ruggedness, and integrated control functions for competitive use.	Provides the racing cyclist with a competitive advantage through high efficiency and integrated control functions.	<ul style="list-style-type: none"> • Dual control lever (ST-7400) allows shifting and braking without releasing the handlebar or brake hood. • Dual-pivot SLR brake caliper (BR-7403) increases stopping power with no increase in lever input. • 8-speed SIS bar end shifter (SL-BSS0-8S) now available.
DURA-ACE	The top line component group for track racing.	Features great strength, light weight, and high mechanical precision for the track racing environment.	Provides the track racer with a "fraction-of-a-second" performance advantage.	<ul style="list-style-type: none"> • Dual-pivot Super SLR brake caliper (BR-6403) increases braking power with no increase in lever input. • Super SLR brake lever (BR-6403) features fast cable take-up action to enhance operation of Super SLR caliper. • SG gear (on FC-6400 crankset) features special shift points that smooth-out and speed-up chainwheel shifts.
SHIMANO 600 ULTEGRA	A high performance road component group for racing enthusiasts and performance oriented cyclists.	Features precision mechanisms, durable design, and a modern high-tech appearance.	Provides the amateur racer and performance cycling enthusiast with a quality high performance racing-type bicycle.	
SHIMANO 105 SC	An affordable sport-racing component group for lightweight racing-style bicycles.	Features high-performance functions and a racing image.	Provides sport and fitness cyclists with a high-performance racing-style bicycle with Shimano advanced control functions.	
SHIMANO RX100	A sport cycling component group for the entry level racing style bicycle.	Features all the same functions of 105SC at a more affordable price and slightly heavier weight.	Provides sports, fitness, and casual cyclists with high-performance functions in an easy-to-ride bicycle.	
EXAGE 500EX EXAGE 400EX EXAGE 300EX	A general purpose affordable sport component group for casual and sport bicycles.	Features many Shimano advanced control functions plus an easy comfortable cycling feeling.	Provides a wide range of casual cyclists with a high-performance feeling in safe and easy-to-control bicycle.	

Road Component Group Positioning

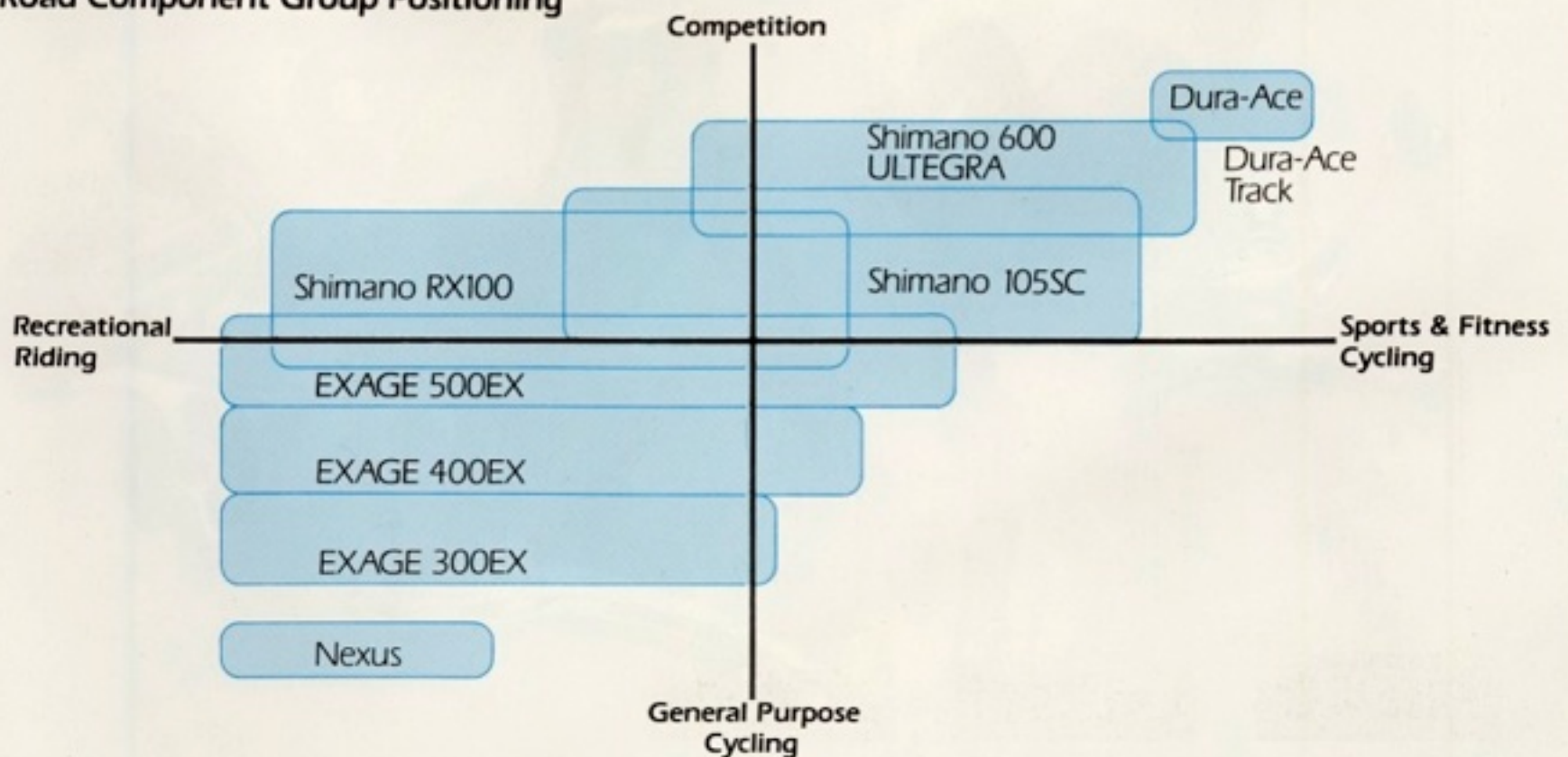

DURA-ACE

ROAD

SHIMANO
TOTAL
INTEGRATION

Dura-Ace was developed to give the professional racing cyclists a fraction-of-a-second advantage that can spell the difference between victory and defeat. Advanced functions like 8-speed SIS, Super SLR brakes, and Shimano Total Integration provide the most refined feeling of control available in a racing group today. Ultra high-precision mechanisms, quality materials, and rugged construction assure that Dura-Ace takes all the punishment that pro-level road racing can dish out.

15

Dura-Ace



DURA-ACE

ROAD



Rear Derailleur
RD-7402

- Weight** 209g.
- Compatibility** Shimano Total Integration Compatible, 6, 7 & 8-speed SIS Compatible
- Features** Adjustable Return Spring, Sealed Link Pivots, Sealed Guide Pulley, Ceramic Guide Pulley Bush, Sealed Tension Pulley, Ceramic Tension Pulley Bush, Sealed Pivot & Bracket Axes (O-Rings), Double Servo-Panta Mechanism, B-Tension Adjust Bolt, Double Spoke Barrier, Chain Retainer
- Capacity** Maximum Rear Sprocket: 26T, Minimum Rear Sprocket: 12T, Front Difference: 14T, Total Capacity: 26T.
- Material & Finish** Forged Light Alloy•Color Anodized Finish (Bracket & Pulley Body), Forged Light Alloy•Inlaid Epoxy & Anodized Finish (Right Link), Forged Light Alloy•Anodized Finish (Left Link, Right & Left Plate)

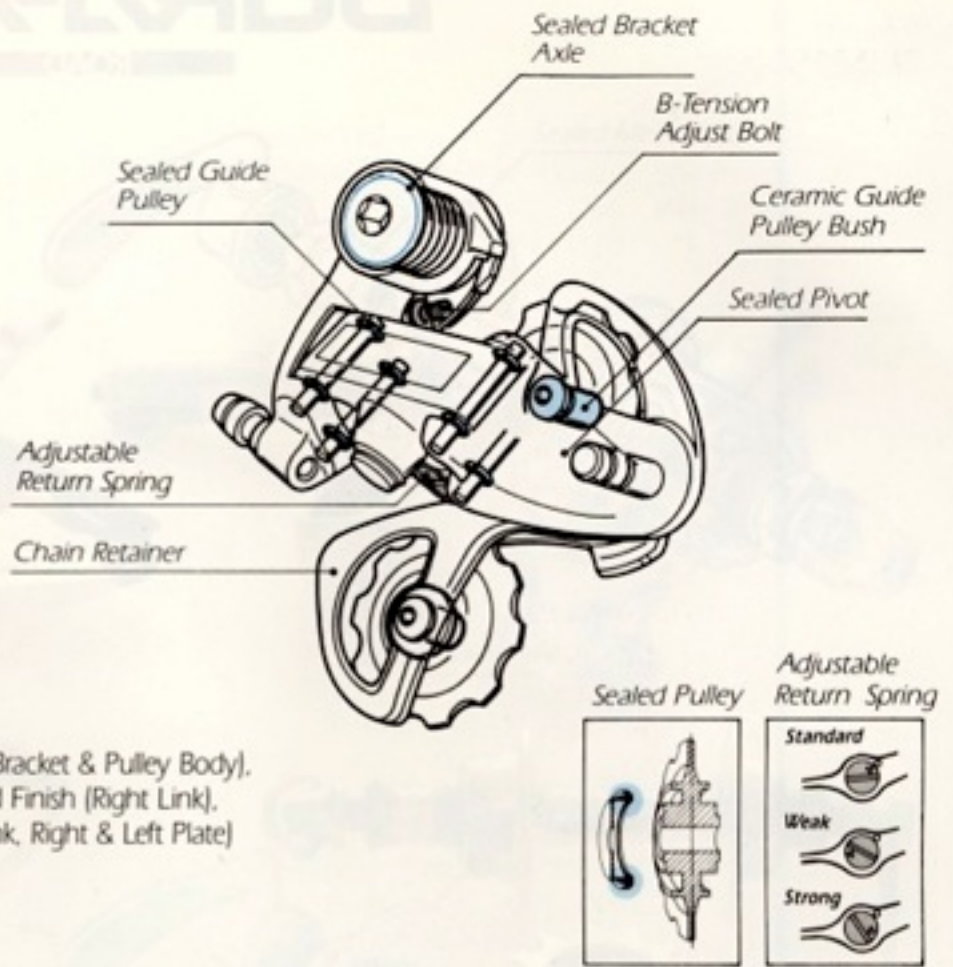

Front Derailleur

FD-7403-B (Band Type)
FD-7403-F (Italian Brazed-on A Type)

- Weight** 93g.
- Compatibility** Shimano Total Integration Compatible, Shimano SG Gear Compatible, Narrow Type Chain Compatible
- Features** Sealed Link Pivots, Rigid Chain Guide, Adjustable Return Spring
- Capacity** 15T.
- Clamp Diameter** 28.0mm.—28.6mm.
- Material & Finish** Forged Light Alloy•Anodized Finish (Front & Rear Band), Forged Light Alloy•Color Anodized (Right Link), Forged Light Alloy (Left Link), Steel•Chrome-Plated (Chain Guide, Clamp Bolt)

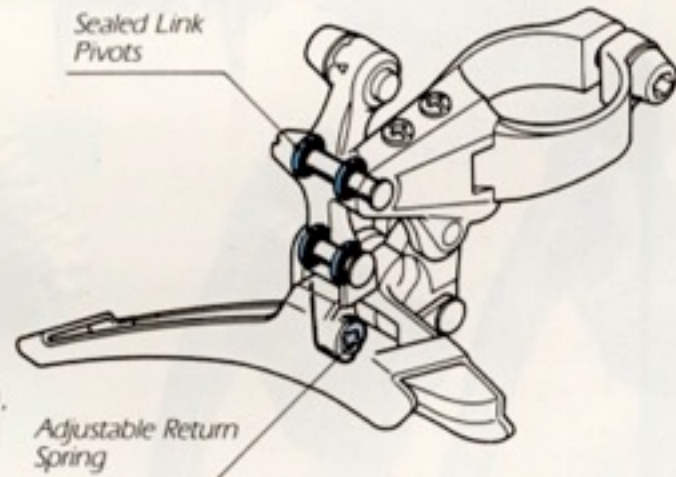

Dual Control Lever
ST-7400

- Weight** 560g.
- Compatibility** Shimano Total Integration Compatible, 8-speed SIS Compatible, Super-SLR Compatible
- Features** Light Action Lever, Sealed Mechanism, Aerodynamic Design, Anatomical Design
- Lever Clamp Diameter** 23.8mm.—24.2mm.
- Material & Finish** Light Alloy•Chrome Plated (Bracket), Forged Light Alloy•Anodized Finish (Lever)
- Use** SIS-SP Sealed Outer Casing with Liner (Lever Side) and SIS Sealed Outer Casing with Liner (Rear Side)

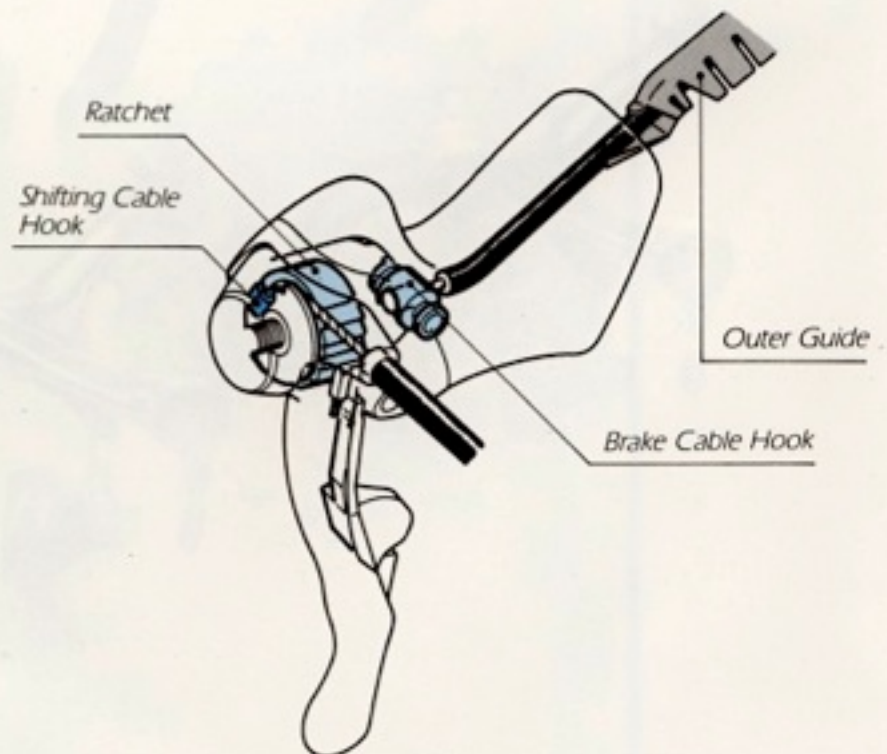

Shifting Lever

SL-7402-FCAI (8-speed SIS, Brazed-on A Type)

C means Italian Type (Fixing Bolt is 5mm. Diameter)

Weight	67g.
Features	8-speed SIS, SIS-Friction Mode Switch, Light Action Lever, Sealed Mechanism, Human Engineered Design, 30° Off-set of Lever Stopper, Sealed Outer Casing
Material & Finish	Light Alloy•Paint Finish (Lever), Resin•Chrome Plated (Top-mount Housing)
Type	Down Tube Lever
Lever Clamp Diameter	28.6mm.

Shifting Lever

SL-7401-BCAI (7-speed SIS, Band A Type)

SL-7401-FCAI (7-speed SIS, Brazed-on A Type)

SL-7401-FCBI (7-speed SIS, Brazed-on B Type)

C means Italian Type (Fixing Bolt is 5mm. Diameter)

Weight	65g. (SL-7401-FCAI)
Features	7-speed SIS, SIS-Friction Mode Switch, Sealed Mechanism, Human Engineered Design, 30° Off-set Lever Stopper, Sealed Outer Casing
Material & Finish	Light Alloy•Paint Finish (Lever), Resin•Molding (Top-mount Housing)
Type	Down Tube Lever
Lever Clamp Diameter	28.6mm.
Use	For SIS Function, use with Dura-Ace Rear Derailleur/Freehub/ Cassette Sprockets/Shimano SIS Outer Casing with Liner.

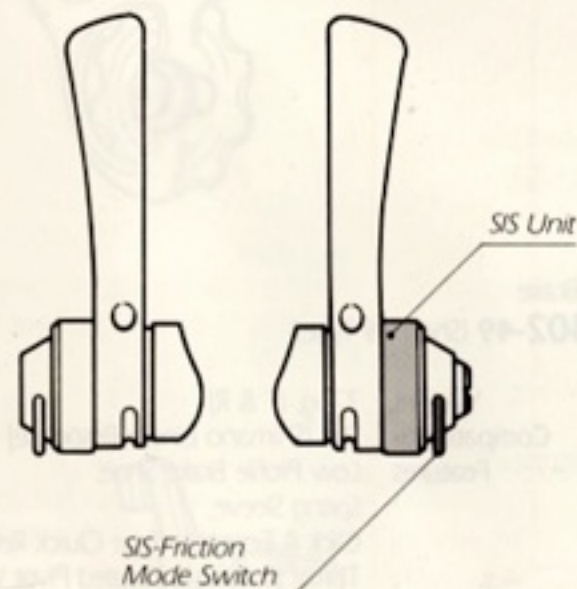

Shifting Lever

SL-7400-BCAI (6-speed SIS, Band A Type)

SL-7400-FCAI (6-speed SIS, Brazed-on A Type)

SL-7400-FCBI (6-speed SIS, Brazed-on B Type)

C means Italian Type (Fixing Bolt is 5mm. Diameter)

Weight	72g. (SL-7400-FCAI)
Features	6-speed SIS, SIS-Friction Mode Switch, Sealed Mechanism, Human Engineered Design
Material & Finish	Light Alloy•Buff Finish (Lever), Resin•Molding (Top-mount Housing)
Type	Down Tube Lever
Lever Clamp Diameter	28.6mm.
Use	For SIS Function, use with Dura-Ace Rear Derailleur/Freehub/ Cassette Sprockets/Shimano SIS Outer Casing with Liner

Shifting Lever

SL-BS50-8

Weight	183g.
Features	8-speed SIS, SIS-Friction Mode Switch, Light Action Lever, Sealed Mechanism, Human Engineered Design, Sealed Outer Casing
Material & Finish	Light Alloy•Paint Finish (Lever)
Type	Bar End Type
Bar Inner Diameter	19.0mm.—22.0mm.
Use	For SIS Function, use with Dura-Ace Rear Derailleur/Freehub/ Cassette Sprockets/Shimano SIS-SP outer casing with liner

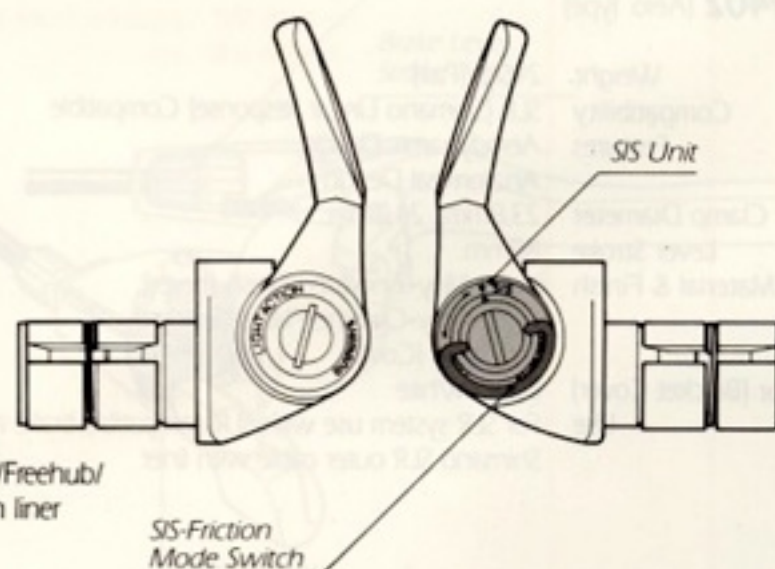

Dual Pivot Brake

BR-7403-49 (Short 49 Type)

- Weight 432g. (F & R)
- Compatibility Shimano Total Integration Compatible, Super SLR (Shimano Linear Response) Compatible
- Features Easy Adjust, Low Profile Brake Shoe, Spring Adjust Pin, Click & Eccentric Type Quick Release, Thrust Bearing & Coated Pivot Washer
- Material & Finish Forged Light Alloy•Anodized Finish (Arch), Light Alloy•Color Anodized Finish (Shoe Holder with Tire Guide)
- Use BR-7403 must be used as a set with ST-7400 and the Shimano SLR Outer Cable with Liner. No other combination can be used.

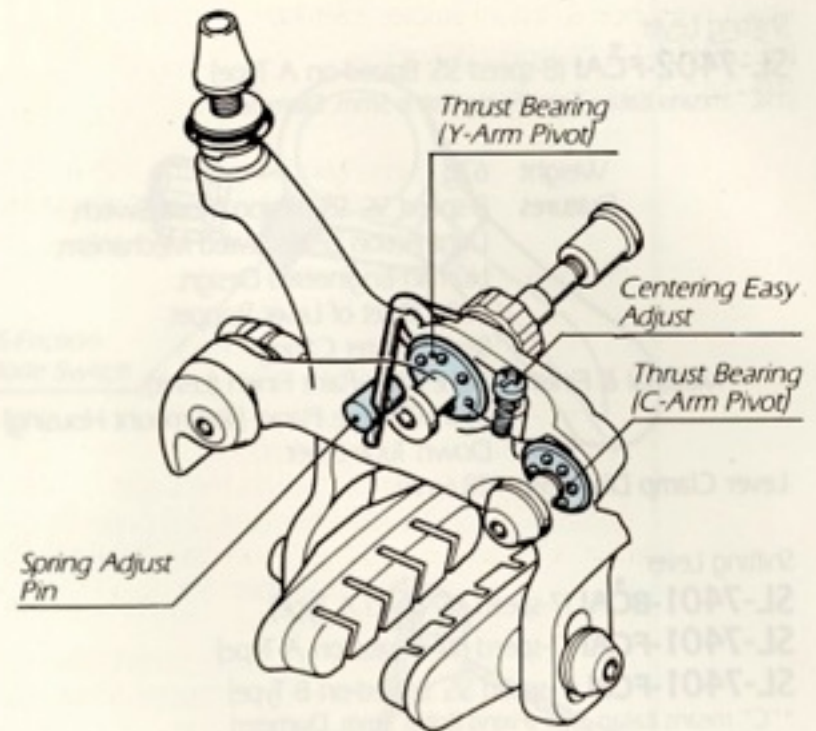

Caliper Brake

BR-7402-49 (Short 49 Type)

- Weight 376g. (F & R)
- Compatibility SLR (Shimano Linear Response) Compatible
- Features Low Profile Brake Shoe, Spring Sleeve, Click & Eccentric Type Quick Release, Thrust Bearing & Coated Pivot Washer
- Material & Finish Forged Light Alloy•Anodized Finish (Arch), Light Alloy•Color Anodized Finish (Shoe Holder with Tire Guide)
- Use For SLR System use with SLR compatible brake lever and Shimano SLR outer cable with liner.

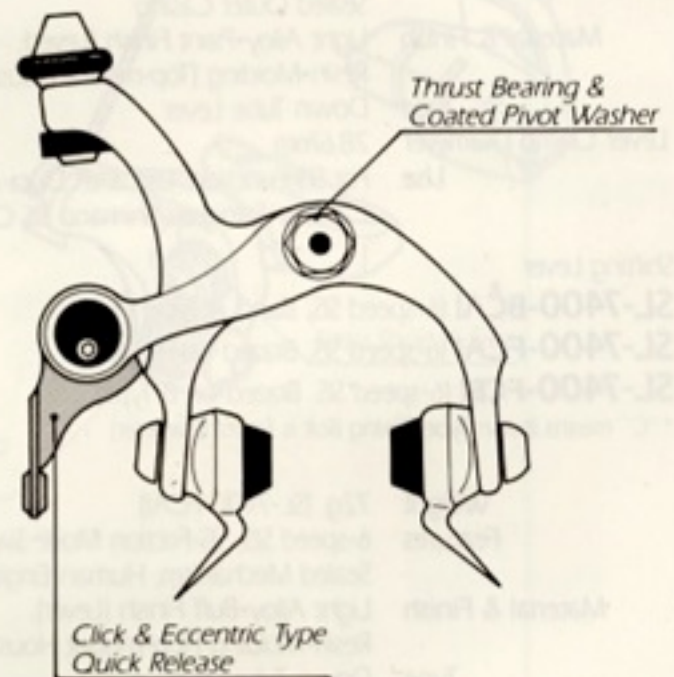

Brake Lever

BL-7402 (Aero Type)

- Weight 240g. (Pair)
- Compatibility SLR (Shimano Linear Response) Compatible
- Features Aerodynamic Design, Anatomical Design
- Lever Clamp Diameter 23.8mm., 24.2mm.
- Lever Stroke 88mm.
- Material & Finish Light Alloy•Anodized Finish (Lever), Light Alloy•Chrome-Plated (Bracket), Soft Resin (Cover)
- Color (Bracket Cover) Black, White
- Use For SLR system use with SLR compatible brake and Shimano SLR outer cable with liner.

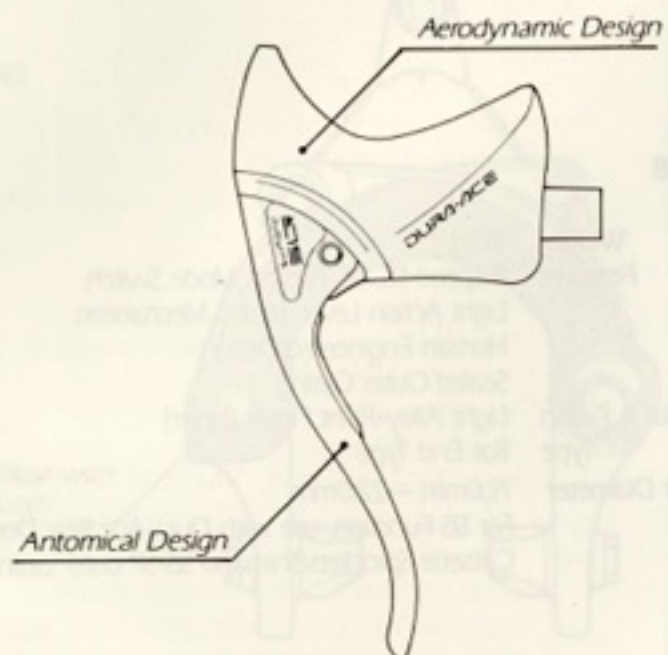

Front Chainwheel & Bottom Bracket Assembly

FC-7402-SG (Double, LD Type)

BB-7400 (B.B. Set)

- Weight** 643g. (42T, 52T, 170mm.), 292g. (B.B. Set)
- Compatibility** Shimano Total Integration Compatible, Narrow Type Chain Compatible
- Features** Sealed Mechanism (B.B.), Shimano SG Gear
- Use** For 1/2" x 3/32" Chain
- Teeth Combination** A-53 x 42, A-52 x 42, B-53 x 39
- Crank Length** 165mm., 167.5mm., 170mm., 172.5mm., 175mm., 177.5mm., 180mm.
- Crank Thread** English BC 9/16" x 20TPI.
- Cut Thread** English BC 1.37 x 24TPI, French M35 x 1.0, Italian M36 x 24TPI.
- B.B. Size** 70-W-113, 68-W-112
- Material & Finish** Forged Light Alloy•Anodised Finish (Crank, Chainring), Light Alloy•Etched-Anodized Finish (Crank Arm Cap), Nickel Cr-Mo Axle



Freehub

FH-7403-HG (Rear, 8-speed)

- Weight** 439g. Rear (with Quick Release)
- Compatibility** Shimano Total Integration Compatible, 8-speed SIS Compatible, HG Gear compatible,
- Features** Lip type Sealed Mechanism, Uni-Balance System, Lubrication Ports with Open/Closed Indicated, Stainless Steel Ball Bearings
- Over Lock Nut Dimensions** 130mm.
- Axle Length** 141mm.
- Axle Thread** M10
- Spoke Holes** 28H, 32H, 36H
- Hole PCD** 44
- Chain Line** 42.65mm.
- Material & Finish** Forged Light Alloy•Anodized Finish (Hub Shell)

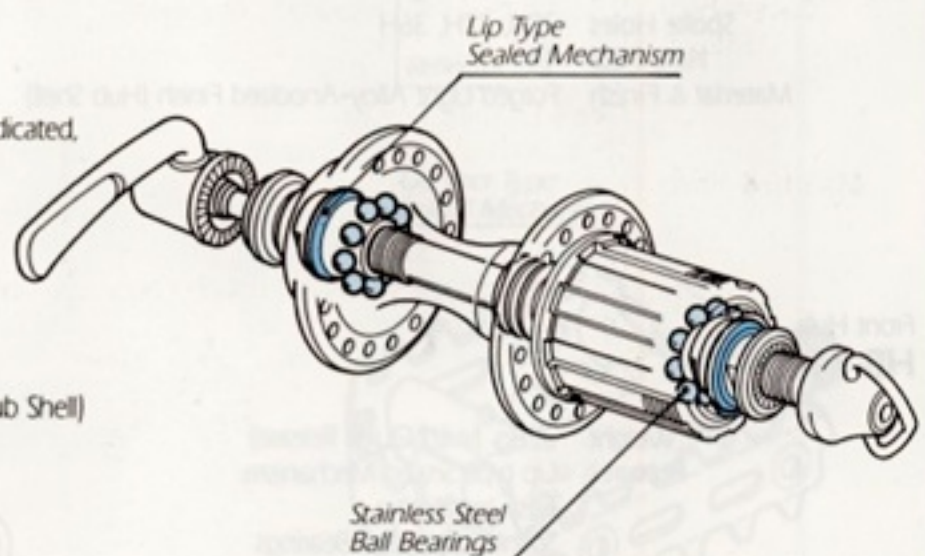

Freehub

FH-7402-8 (Rear, 8-speed)

- Weight** 460g. Rear (with Quick Release)
- Compatibility** 8-speed SIS Compatible
- Features** Lip type Sealed Mechanism, Uni-Balance System, Lubrication Ports with Open/Closed Indicated, Stainless Steel Ball Bearings
- Over Lock Nut Dimensions** 130mm.
- Axle Length** 141mm.
- Axle Thread** M10
- Spoke Holes** 28H, 32H, 36H
- Hole PCD** 44
- Chain Line** 42.65mm.
- Material & Finish** Forged Light Alloy•Anodized Finish (Hub Shell)

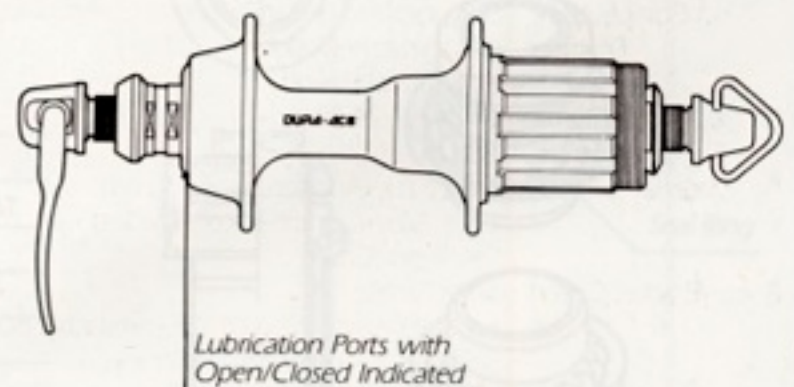

Freehub

FH-7400-7/6 (Rear, 7/6-speed)

Weight	439g. Rear (with Quick Release)
Compatibility	7 & 6-speed SIS Compatible
Features	Lip Type Sealed Mechanism, Uni-Balance System, Lubrication Ports with Open/Closed Indicated, Stainless Steel Ball Bearings
Over Lock Nut Dimensions	126.5mm.
Axle Length	137mm.
Axle Thread	M10
Spoke Holes	28H, 32H, 36H
Hole PCD	44
Chain Line	42.6mm. (7-speed), 42.95mm. (6-speed)
Material & Finish	Forged Light Alloy•Anodized Finish (Hub Shell)

Hub

HB-7400-R (Rear, 7/6-speed)

Weight	315g. (with Quick Release)
Compatibility	7 & 6-speed SIS Compatible
Features	Lip Type Sealed Mechanism, Uni-Balance System, Lubrication Ports with Open/Closed Indicated, Stainless Steel Ball Bearings
Over Lock Nut Dimensions	126mm.
Spoke Holes	28H, 32H, 36H
Hole PCD	44
Material & Finish	Forged Light Alloy•Anodized Finish (Hub Shell)

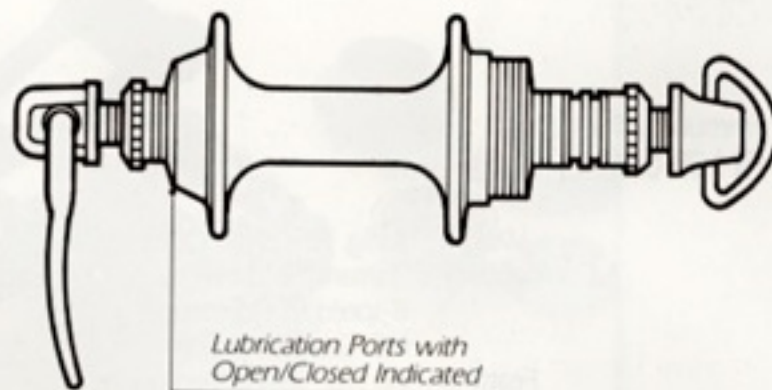

Front Hub

HB-7400-F

Weight	228g. (with Quick Release)
Features	Lip type Sealed Mechanism, Easy Installation, Stainless Steel Ball Bearings
Over Lock Nut Dimensions	100mm.
Axle Length	108mm.
Axle Thread	M9
Spoke Holes	28H, 32H, 36H
Hole PCD	38
Material & Finish	Forged Light Alloy•Anodized Finish (Hub Shell)

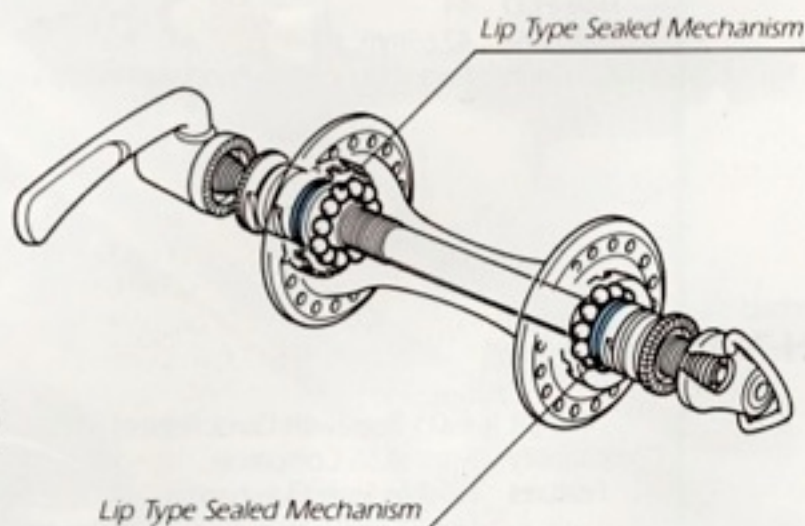

Cassette Sprockets

CS-7401-8 (8-speed HG)

Weight Compatibility 255g. (Sprocket S Group & Spacer)
 Shimano Total Integration Compatible,
 8-speed SIS Compatible,
 Narrow Type Chain Compatible

Feature 8-speed HG

Material & Finish Steel•Champagne Gold Finish (Sprocket)

Sprocket Combinations

S	12, 13, 14, 15, 16, 17, 19, 21T.
T	13, 14, 15, 16, 17, 19, 21, 23T.
U	12, 13, 14, 15, 17, 19, 21, 23T.

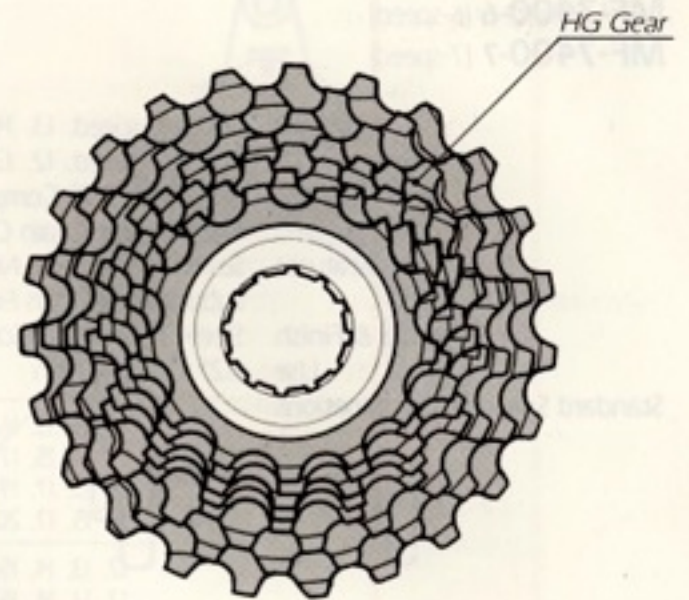

Cassette Sprockets

CS-7400-8 (8-speed)

Weight Compatibility 255g. (Sprocket 12—21T. & Spacer)
 8-speed SIS Compatible,
 Narrow Type Chain Compatible

Feature New Uniglide Teeth

Teeth Threaded Sprocket; 12T.—14T.,
 Built-in Spacer Type Sprocket; 13T.—15T.,
 Spline Sprocket; 14T.—26T., 28T.

Material & Finish Steel•Champagne Gold Finish (Sprocket)

Standard Sprocket Combinations

	12, 13, 14, 15, 16, 17, 18, 19T.
	12, 13, 14, 15, 16, 17, 19, 21T.
8-speed	13, 14, 15, 16, 18, 20, 22, 24T.
	13, 14, 15, 16, 17, 18, 19, 21T.
	13, 14, 16, 18, 20, 22, 24, 26T.

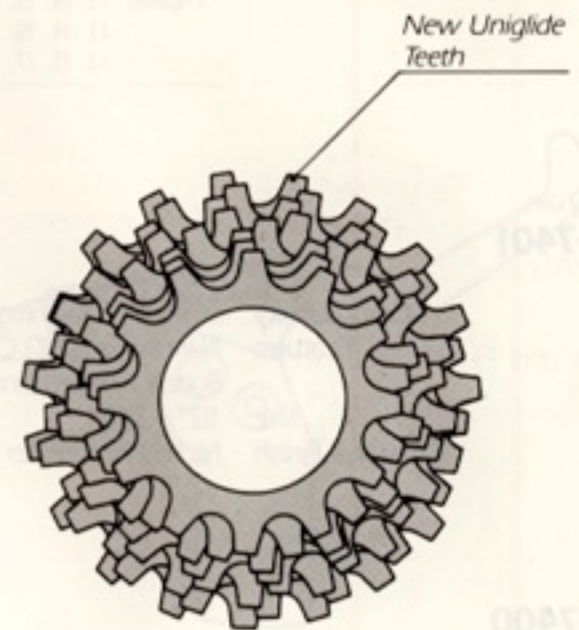

Cassette Sprockets

CS-7400-6/7 (6-speed/7-speed)

Weight 208g. (6-speed; Sprocket 13—21T. & Spacer)
 221g. (7-speed; Sprocket 12—21T. & Spacer)

Compatibility 6 & 7-speed SIS Compatible,
 Narrow Type Chain Compatible (7-speed)

Feature New Uniglide Teeth

Teeth Threaded Sprocket; 12T.—14T.,
 Built-in Spacer Type Sprocket; 13T.—15T.,
 Spline Sprocket; 14T.—26T., 28T.

Material & Finish Steel•Champagne Gold Finish (Sprocket)

Standard Sprocket Combinations

	12, 13, 14, 15, 16, 17T.
	13, 14, 15, 16, 17, 18T.
6-speed	13, 14, 15, 17, 19, 21T.
	13, 15, 17, 19, 21, 23T.
	13, 15, 17, 20, 23, 26T.
7-speed	12, 13, 14, 15, 16, 17, 19T.
	12, 13, 14, 15, 17, 19, 21T.
	13, 14, 15, 16, 17, 19, 21T.
	13, 14, 15, 17, 19, 21, 24T.
	13, 15, 17, 19, 21, 23, 26T.

Multiple Freewheel

MF-7400-6 (6-speed)

MF-7400-7 (7-speed)

Weight 360g. (6-speed: 13, 14, 15, 17, 19, 21T),
367g. (7-speed: 12, 13, 14, 15, 17, 19, 21T.)

Compatibility 6 & 7-speed SIS Compatible,
Narrow Type Chain Compatible (7-speed)

Features Sealed Mechanism, New Uniglide Teeth,
Lubrication Port on Freewheel Body

Material & Finish Steel•Champagne Gold Finish (Sprocket)

Use 1/2" x 3/32" Chain

Standard Sprocket Combinations

13, 14, 15, 16, 17, 18T.

6-speed 13, 14, 15, 17, 19, 21T.

13, 15, 17, 19, 21, 23T.

13, 15, 17, 20, 23, 26T.

7-speed 12, 13, 14, 15, 16, 17, 18T.

12, 13, 14, 15, 17, 19, 21T.

13, 14, 15, 16, 17, 19, 21T.

13, 14, 15, 17, 19, 21, 24T.

13, 15, 17, 19, 21, 23, 26T.



HG Chain

CN-7401

Compatibility Shimano Total Integration Compatible

Features Narrow Type HG Chain,
Boron Finished Link Pins

Size 1/2" x 3/32"

Material & Finish Nickel Finish (Roller Link Plate, Pin Link Plate)

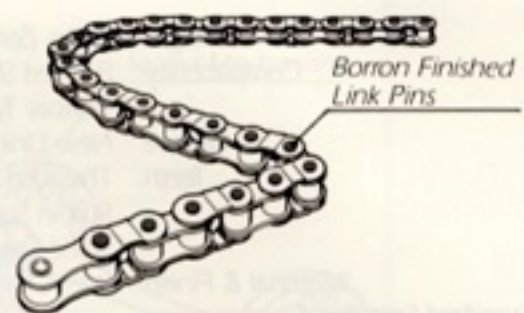

Pedal

PD-7400

Weight 372g. (Pair, Including Toe Clip Size L)

Features 34° Road Clearance,
Compound Structure of Needle Bearing and Cup & Cone,
Aerodynamic Design, Sealed Mechanism

Material & Finish Light Alloy•Buff Finish (Body),
Light Alloy•Anodized Finish (Front Plate),
Light Alloy•Black Solid Anodized Finish (Rear Plate),
Nickel Cr-Mo Steel•Chrome-Plated/Polished Finish (Axle),
Steel Chrome-Plated or Light Alloy•Anodized Finish (Toe Clip)

Toe Clip Size M, L, LL

Crank Thread English BC 9/16" x 20TPI.

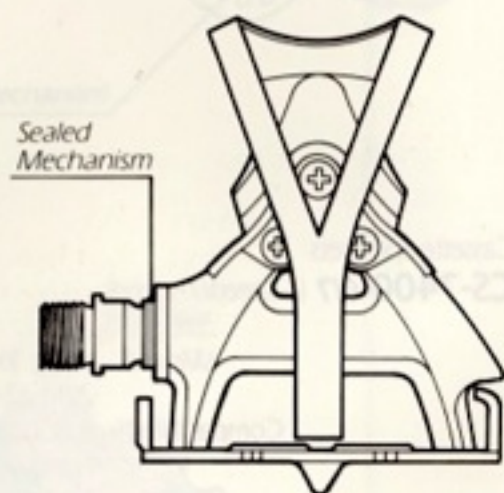

Clipless Pedal

PD-7401

Weight 416g. (Pedal, Pair), 92g. (Cleat & Hard Wear)

Features 34° Road Clearance,
Compound Roller & Ball Bearing Axle,
Aerodynamic Dustcapless Design,
Efficient Sealed Mechanism,
Adjustable Cleat Grip Tension, Compatible Look® Cleats

Material & Finish Forged Light Alloy•Paint Finish (Body),
Nickel Cr-Mo Steel•Chrome-Plated Polished Finish (Axle)

Crank Thread English BC 9/16" x 20TPI.

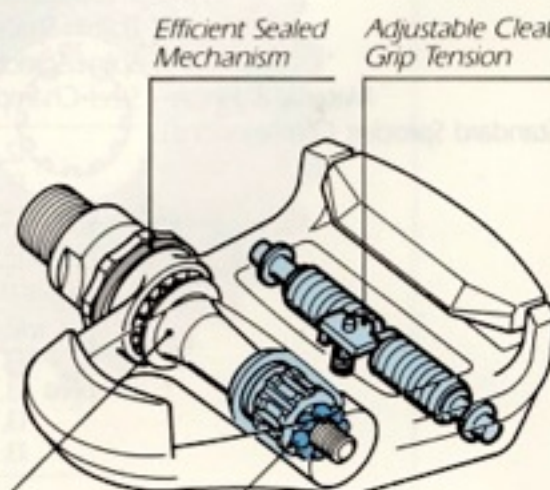

Compound Roller & Ball Bearing Axle

Sealed Mechanism

Seat Pillar

- SP-7400-A** (Round Tube, A Type)
- SP-7400-B** (Semi Oval Tube, B Type)

Weight 224g. (A Type), 244g. (B Type)
 Features Aerodynamic Design, Hexagon Release
 Material & Finish Light Alloy•Anodized Finish
 Outside Diameter 25.0mm., 26.0mm., 26.2mm., 26.4mm., 26.6mm., 26.8mm., 27.0mm., 27.2mm., 27.4mm.

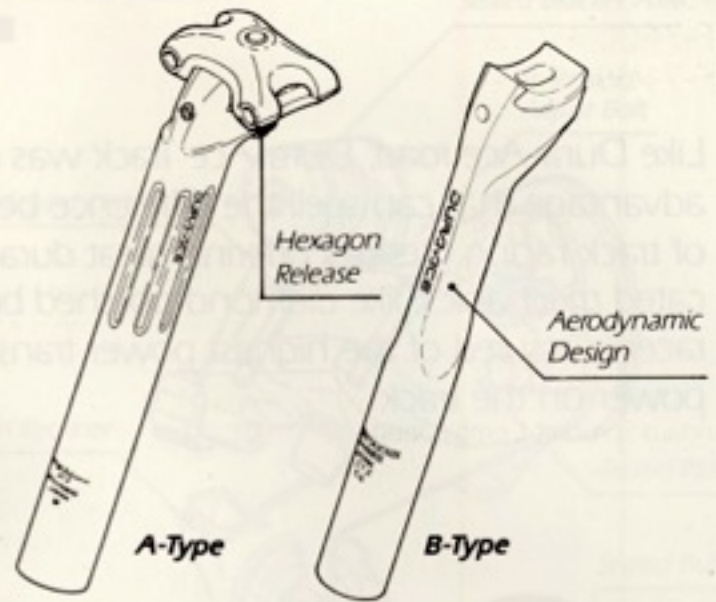

Handle Stem
HS-7400

Weight 252g. (100mm.), 260g. (120mm.)
 Features Aerodynamic Design, Hexagon Release
 Material & Finish Forged Light Alloy•Anodized Finish
 Extension 70mm., 80mm., 90mm., 100mm., 110mm., 120mm., 130mm.
 Handle Stem Diameter 22.2mm.
 Handlebar Clamp Diameter 26.0mm.

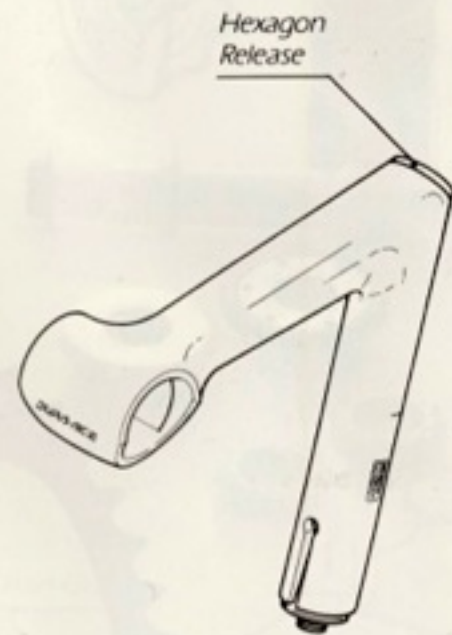

Head Parts
HP-7400

Weight 113g.
 Type Road Type
 Features Sealed Mechanism,
 Material & Finish Forged Light Alloy•Anodized Finish (Nut, Cup, Upper Cone), Titanium-Plated (Lower Cone), Bearing Steel Insertion
 Height Variation Upper Cone 22.8mm., Lower Cone 13.5mm.

Type	Thread	Press Race Diameter	
		Upper Cone & Lower Cup	Lower Cone
English/Italian	BC1 x 24T.	30.2mm.	26.4mm.
French	M25 x P1.0	30.2mm.	26.4mm.

Dimensions

t_1	22.8mm.
t_2	13.5mm.
H	Head Tube Length
A	22.3mm.
B	30.2mm.
C	26.4mm.
Thread	BC 1" x 24T. (English, Italian Thread) / M25" x P1.0 (French Thread)

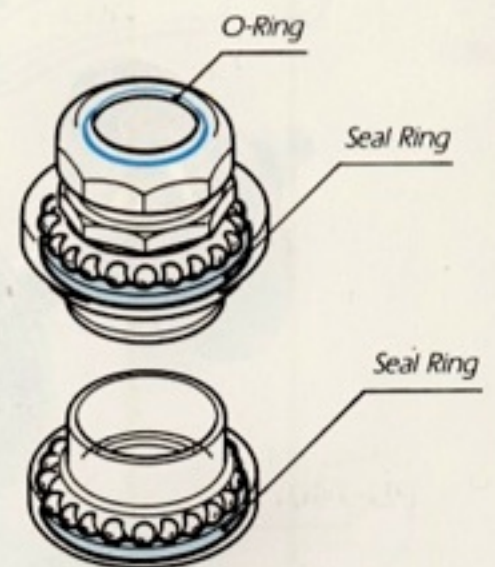
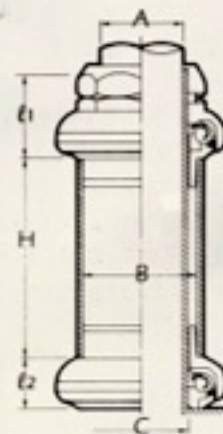

DURA-ACE

TRACK

SHIMANO
TOTAL
INTEGRATION

Like Dura-Ace road, Dura-Ace Track was designed to give the racer a fraction-of-a-second advantage that can spell the difference between victory and defeat in the highly competitive world of track racing. Besides offering great durability and rigidity, Dura-Ace Track features highly sophisticated mechanics, like diamond polished bearing races for example. As a result, the Dura-Ace Track racer is assured of the highest power transfer efficiency—the key to converting leg power into go power on the track.



Hub
HB-7600 (Large & Small Flange)

- Weight** 313g. (Rear Large Flange w/Lock Ring), 241g. (Front Large Flange)
- Features** Precision Ground Cones, Diamond-Polished Mirror Finish (Cup & Cones), Sealed Mechanism, Composite-Type Design (Large Flange)
- Over Lock Nut Dimensions** Front: 100mm., Rear: 120mm.
 (One-Side or Both-Side Threaded Type, Small Flange/Large Flange)
- Spoke Holes** 24H, 28H, 32H, 36H
- Spoke Hole Diameter** \varnothing 2.4mm.
- Material & Finish** Forged Light Alloy•Anodized Finish (Hub Body), Resin Composit Hub Shell
- Fork End Slot Width** Front: 9mm. (Hollow Axle), Rear: 10mm. (Hollow Axle)

Sealed Mechanism

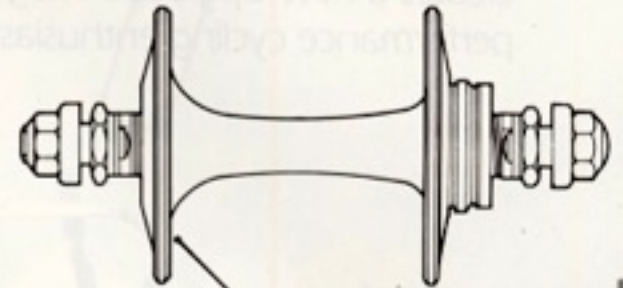

Large Flange

Sprocket
SS-7600 (Hub Sprocket for Track Model)

- Material & Finish** Cr-Mo Steel
- Thread** BC 1.37 x 24T.P.I. (English)
- Standard Sprocket** 1/2" x 1/8", 1/2" x 3/32"
- Teeth** 13T., 14T., 15T., 16T.
- Weight** 1/2" x 1/8" Sprocket:

13T.	31g.
14T.	38g.
15T.	44g.
16T.	53g.



Cr-Mo Steel

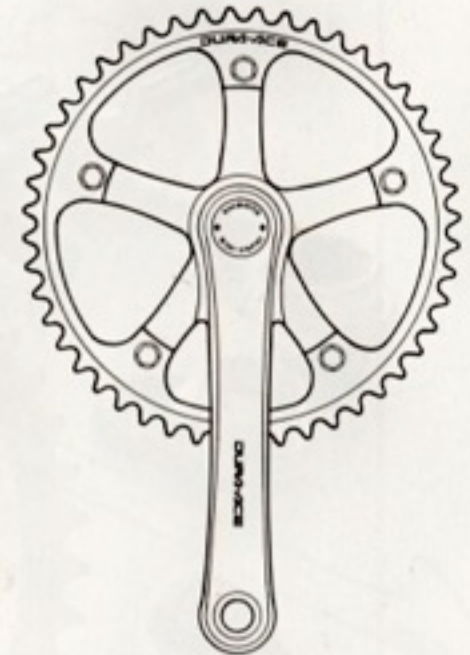

Front Chainwheel & Bottom Bracket Assembly

FC-7600
BB-7600 (B.B. Set)

- Weight** 605g. (48T., 170mm.), 305g. (B.B. Set)
- Features** Exclusively Designed for Track, Removable Sealed Mechanism (B.B.)
- Material & Finish** Forged Light Alloy•Anodized Finish (Crank, Crank Arm Cap), Light Alloy•High-Tech Gray Anodized Finish (Chainring), Nickel Cr-Mo Axle
- Use** For 1/8" & 3/32" Chain
- Teeth** 42T.—55T.
- Crank Length** 165mm., 167.5mm., 170mm., 172.5mm., 175mm.
- Crank Thread** English BC 9/16" x 20T.P.I.
- Cup Thread** English BC 1.37 x 24T.P.I., French M35 x 1.0, Italian M36 x 24T.P.I.
- B.B. Size** 68-S-109, 70-S-109
- B.B. Axle Length** 109

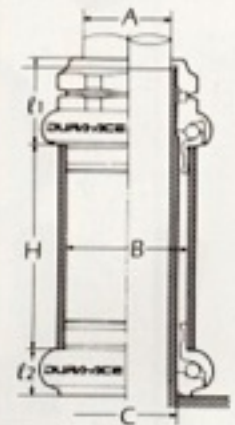

Head Parts
HP-7600

- Weight** 90g.
- Type** Track Type
- Features** Composite Structure, Sealed Mechanism, Super Light Weight
- Material & Finish** Light Alloy•Anodized Finish (Nut, Upper Cone), High Impact Resin (Upper Cone, Lower Cup Covers), Bearing Steel (Upper & Lower Cup), Die Steel•Titanium Plated (Upper & Lower Cone)
- Height Variation** Upper Cone 19.5mm., Lower Cone 11.5mm.

Type	Thread	Press Race Diameter	
		Upper Cone & Lower Cup	Lower Cone
English/Italian	BC1 x 24T.	30.2mm.	26.4mm.
French	M25 x P1.0	30.2mm.	26.4mm.

Dimensions

f ₁	19.5mm.
f ₂	11.5mm.
H	Head Tube Length
A	22.0mm.
B	30.2mm.
C	26.4mm.
Thread	BC 1" x 24T. (English, Italian Thread)/ M25" x P1.0 (French Thread)

SHIMANO 600 ULTEGRA

The Ultegra group was developed to provide a high-performance racing type bicycle for amateur racers and performance oriented sport cyclists. Ultegra features polished bearing races, high strength steels, a strikingly modern color treatment, and compact high-tech design theme. This approach creates a new upgraded image for a fashionable high quality racing-type bicycle aimed at the performance cycling enthusiast.



Rear Derailleur
RD-6400

- Weight** 216g.
- Compatibility** 6 & 7-speed SIS Compatible
- Features** Sealed Link Pivots, Sealed Guide Pulley, Ceramic Guide Pulley Bushing, Sealed Tension Pulley, Sintered Alloy Tension Pulley Bushing, Sealed Pivot & Bracket Axes, Double Servo-Panta Mechanism, Centeron Guide Pulley, B-Tension Adjust Bolt, Double Spoke Barrier, Chain Retainer
- Capacity** Maximum Rear Sprocket: 28T.
Minimum Rear Sprocket: 12T.
Front Difference: 13T.
Total Capacity: 28T.
- Material & Finish** Light Alloy•Dark Gray Paint Finish (Bracket & Plate Body),
Light Alloy•Silver Paint (Right Link),
Light Alloy•Barrel Finish (Pulley Plate & Left Link)

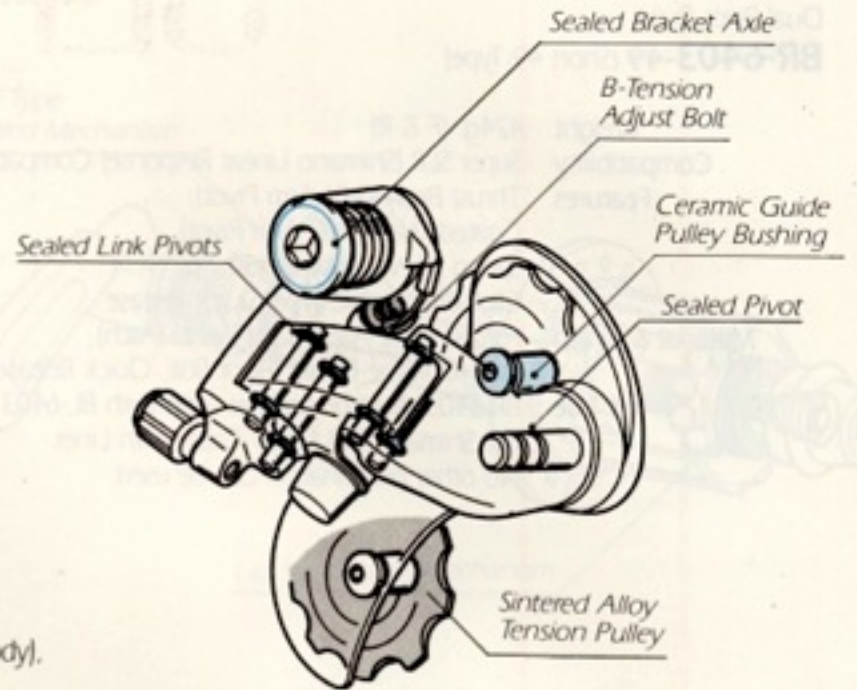

Front Derailleur
FD-6400-B (Band Type)
FD-6400-F (Italian Brazed-on A Type)

- Weight** 104g. (Band Type)
- Features** Leading Action Pantagraph Mechanism, Compact Design, Rigid Chain Guide
- Capacity** 14T.
- Cramp Diameter** 28.0mm.—28.6mm.
- Material & Finish** Light Alloy•Silver Paint Finish (Right Link),
Steel•Chrome-Plated (Chain Guide)
Light Alloy•Dark Gray Paint Finish (Front & Rear Band)

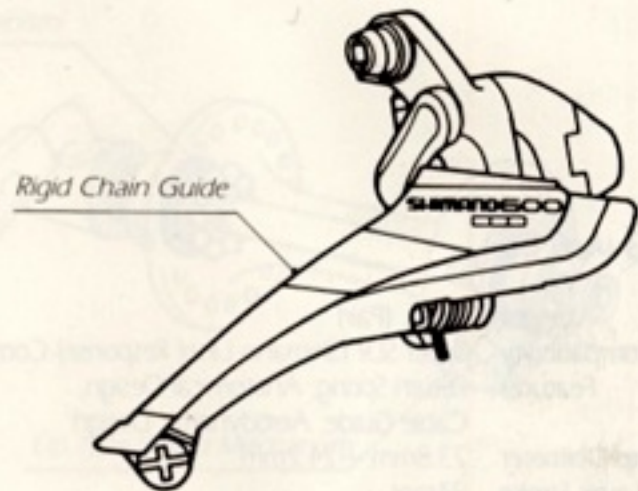

Shifting Lever
SL-6400-FCAI (6 & 7-speed SIS, Brazed-on A Type)
SL-6400-BCAI (6 & 7-speed SIS, Side Band A Type)
C means Italian Type (Fixing Bolt is 5mm. Diameter)

- Weight** 60g. (SL-6400-FCAI)
- Features** Same Lever for 6 & 7-speed SIS, SIS-Friction Mode Switch, Sealed Mechanism, 30° Off-set of Lever Stopper (Front), Light Action Lever (Front), Lever Interchangeability, Human Engineered Design
- Type** Down Tube Lever
- Lever Cramp Diameter** 28.6mm.
- Material & Finish** Light Alloy•Gray Paint Finish (Lever)

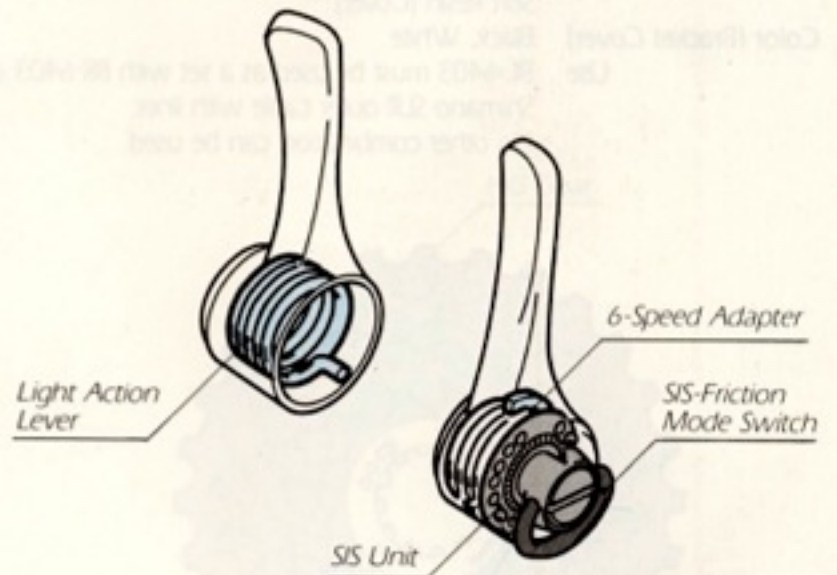

Shifting Lever
SL-BS50

- Weight** 183g.
- Compatibility** 6 & 7-speed SIS Compatible.
- Features** SIS-Friction Mode Switch, Light Action Lever, Sealed Mechanism, Human Engineered Design, Sealed Outer Casing
- Type** Bar End Type
- Bar Inner Diameter** 19.0mm.—22.0mm.
- Material & Finish** Light Alloy•Paint Finish (Lever)

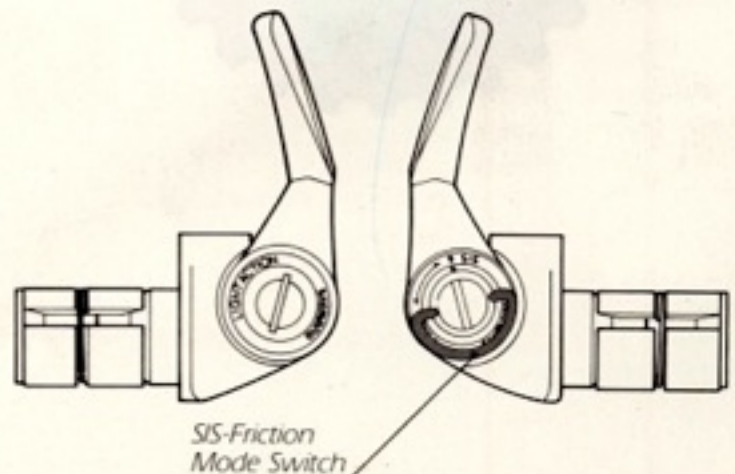

Dual Pivot Brake

BR-6403-49 (Short 49 Type)

- Weight** 424g. (F & R)
- Compatibility** Super SLR (Shimano Linear Response) Compatible
- Features** Thrust Bearing (Y-Arm Pivot), Coated Washer (C-Arm Pivot), Spring Sleeve, Easy Adjust, Click & Eccentric Type Quick Release
- Material & Finish** Forged Light Alloy•Paint Finish (Arch), Steel•Chrome-Plated (Pivot Bolt, Quick Release)
- Use** BR-6403 must be used as a set with BL-6403 and the Shimano SLR Outer Cable with Liner. No other combination can be used.

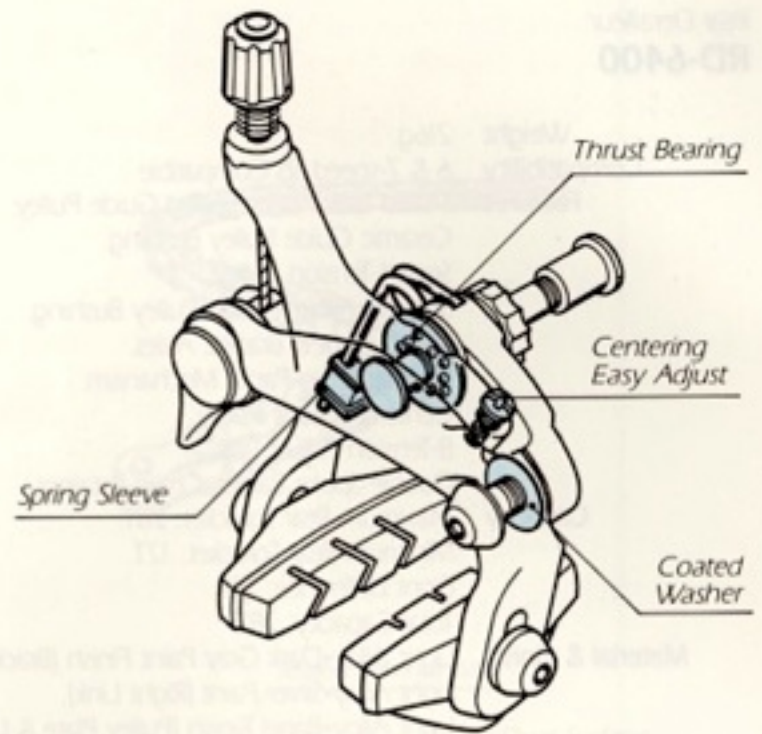

Brake Lever

BL-6403 (Aero Type)

- Weight** 272g. (Pair)
- Compatibility** Super SLR (Shimano Linear Response) Compatible
- Features** Return Spring, Anatomical Design, Cable Guide, Aerodynamic Design
- Lever Clamp Diameter** 23.8mm.—24.2mm.
- Lever Stroke** 84mm.
- Material & Finish** Light Alloy•Paint Finish (Lever), Light Alloy•Barrel Finish (Bracket), Soft Resin (Cover)
- Color (Bracket Cover)** Black, White
- Use** BL-6403 must be used as a set with BR-6403 and the Shimano SLR outer cable with liner. No other combination can be used.

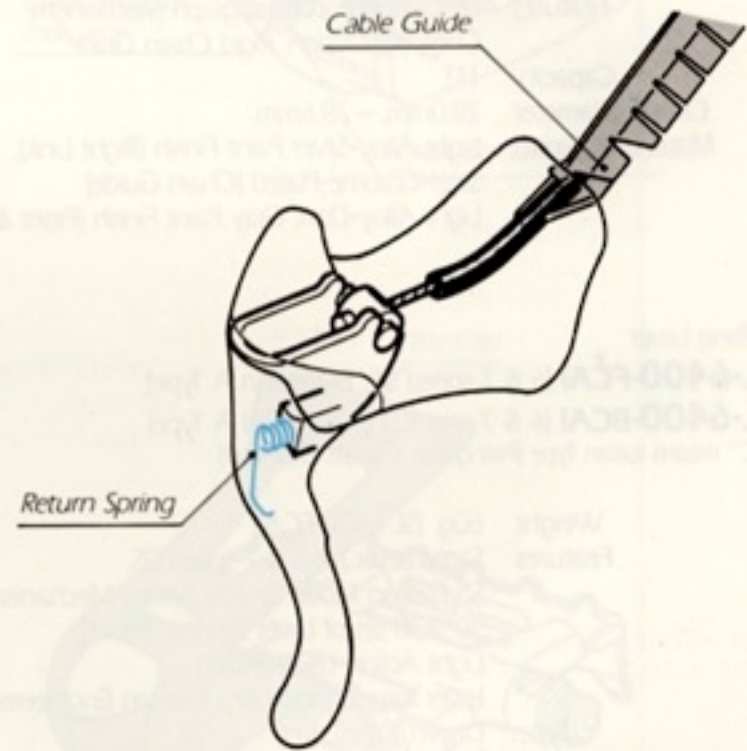

Front Chainwheel & Bottom Bracket Assembly

FC-6400-SG (Shimano SG Double, LD Type)

FC-6400-BP (Biopace Double, LD Type)

BB-6400 (B.B. Set)

- Weight 650g. (42T., 52T., 170mm.), 293g (B.B. Set)
- Features Narrow Type Chain Compatible, Shimano SG Gear (FC-6400-SG), Sealed Mechanism (B.B.)
- Use For 1/2" x 3/32" Chain
- Teeth Combination 52 x 42 (Biopace SG), 53 x 42, 52 x 42 (Shimano SG), 53 x 42, 52 x 42 (Biopace HP)
- Crank Length 165mm., 167.5mm., 170mm., 172.5mm., 175mm.
- Crank Thread English BC 9/16" x 20TPI.
- Cup Thread English BC 1.37 x 24TPI., French M35 x 1.0, Italian M36 x 24TPI.
- B.B. Size 70-W-115, 68-W-113
- Material & Finish Light Alloy•Anodized Finish (Crank, Chainring), Nickel Cr-Mo Axle

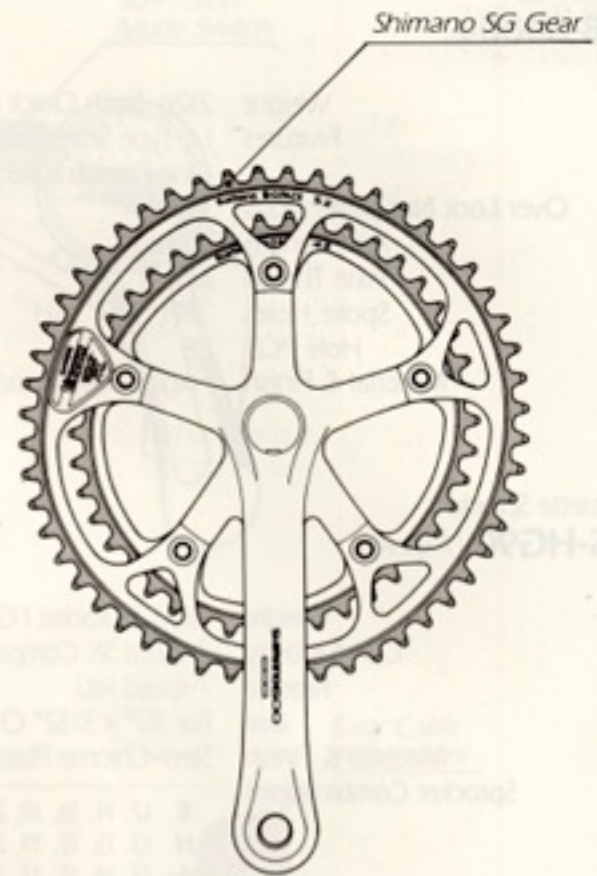

Freehub

FH-6401-HG (7-speed)

- Weight 423g. (with Quick Release)
- Compatibility 7-speed SIS Compatible, HG Gear Compatible
- Features UG/HG Convertible Type, Lip type Sealed Mechanism, Uni-Balance System, One-Piece Forged Hub Body
- Over Lock Nut Dimensions 126mm.
- Axle Length 137mm.
- Axle Thread M10
- Spoke Holes 28H, 32H, 36H
- Hole PCD 45
- Chain Line 41.2mm.
- Material & Finish Forged Alloy•Buff Anodized Finish (Hub Shell), Resin•Black Finish (Dust Cap), Steel•Chrome-Plated (Quick Release Housing)

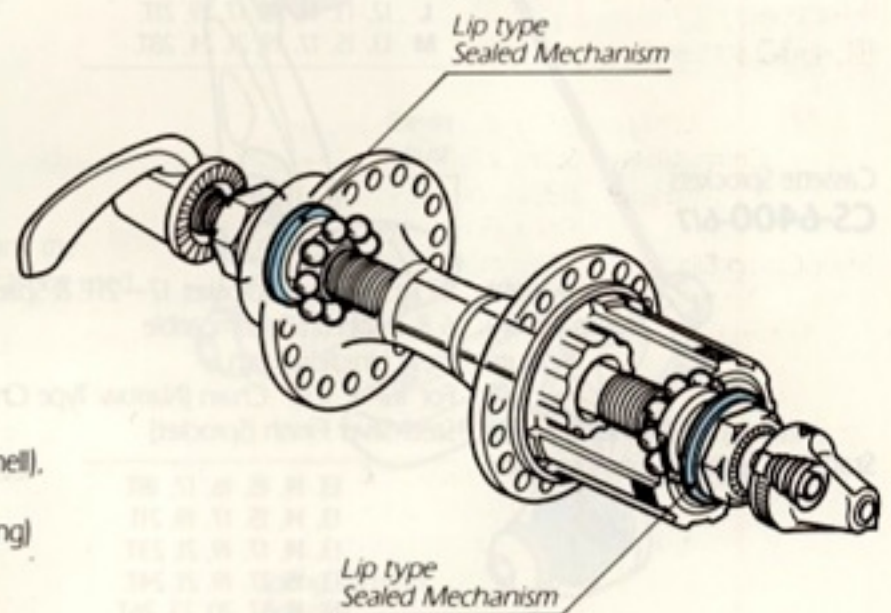

Freehub

FH-6400 (6/7-speed)

- Weight 423g. (w/Quick Release)
- Compatibility 6 & 7-speed SIS Compatible
- Features Sealed Mechanism, Burnished Bearing Races, Uni-Balance System
- Over Lock Nut Dimensions 126mm.
- Spoke Holes 28H, 32H, 36H
- Hole PCD 45
- Material & Finish Light Alloy•Anodized Finish (Hub Shell), Steel•Chrome-Plated (Quick Release Housing)

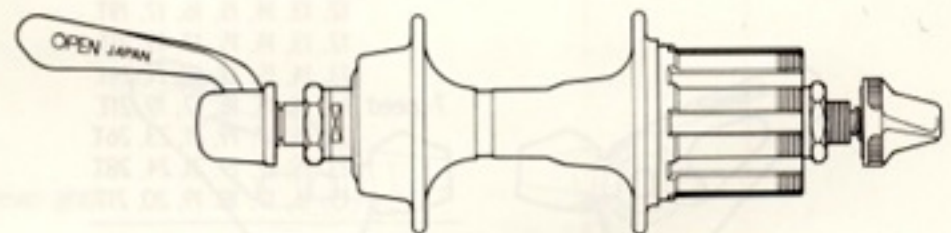

Front Hub
HB-6400-F

Weight 212g. (with Quick Release)
Features Lip type Sealed Mechanism, One-Piece Forged Hub Body
Over Lock Nut Dimensions 100mm.
Axle Length 108mm.
Axle Thread M9
Spoke Holes 28H, 32H, 36H
Hole PCD 38
Material & Finish Forged Alloy-Anodized Finish (Hub Shell)

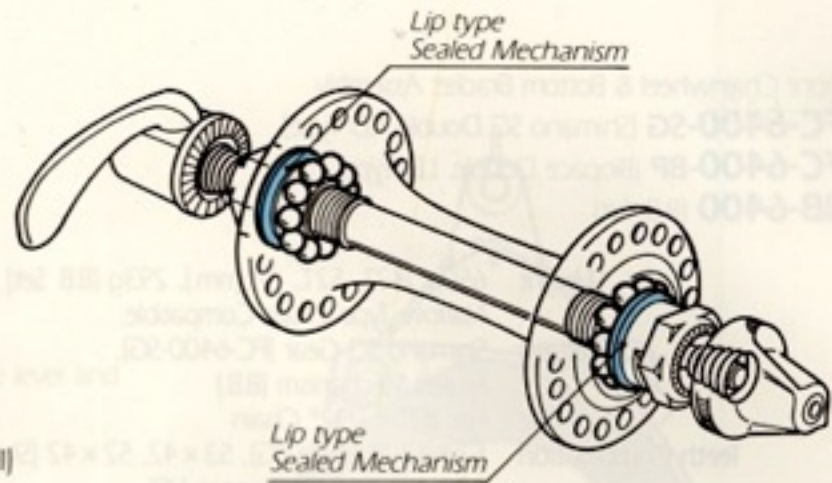

Cassette Sprockets
CS-HG90 (7-speed)

Weight 286g. (Sprocket I Group & Spacer)
Compatibility 7-speed SIS Compatible
Feature 7-speed HG
Use For 1/2" x 3/32" Chain (Narrow Type Chain)
Material & Finish Steel-Chrome Plated
Sprocket Combinations

- E** 12, 14, 16, 18, 21, 24, 28T.
- H** 13, 15, 17, 19, 21, 23, 26T.
- I** 13, 14, 15, 17, 19, 21, 23T.
- J** 13, 14, 15, 16, 17, 19, 21T.
- L** 12, 13, 14, 15, 17, 19, 21T.
- M** 13, 15, 17, 19, 21, 24, 28T.

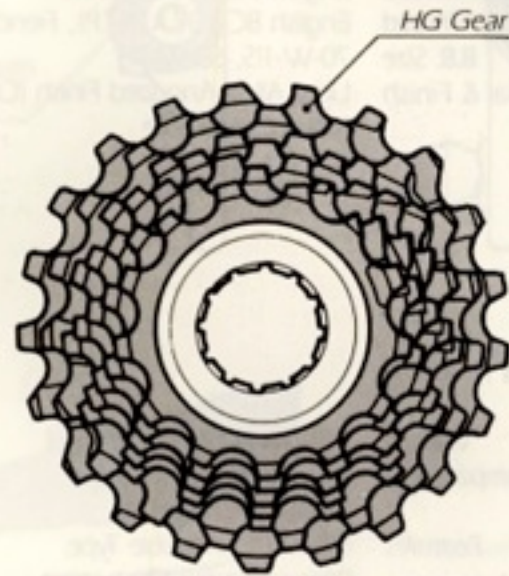

Cassette Sprockets
CS-6400-6/7

Weight 223g. (7-speed Sprocket 12—21T. & Spacer)
Compatibility 6 & 7-speed SIS Compatible
Feature New Uniglide Teeth
Use For 1/2" x 3/32" Chain (Narrow Type Chain)
Material & Finish Steel-Silver Finish (Sprocket)
Standard Sprocket Combinations

- | | |
|---------|------------------------------|
| | 13, 14, 15, 16, 17, 18T. |
| | 13, 14, 15, 17, 19, 21T. |
| | 13, 14, 17, 19, 21, 23T. |
| | 13, 15, 17, 19, 21, 24T. |
| 6-speed | 13, 15, 17, 20, 23, 26T. |
| | 13, 15, 17, 20, 24, 28T. |
| | 12, 14, 17, 20, 24, 28T. |
| | 13, 15, 17, 20, 25, 30T. |
| | 12, 14, 16, 19, 22, 26T. |
| | 12, 14, 17, 20, 25, 30T. |
| 7-speed | 12, 13, 14, 15, 16, 17, 19T. |
| | 12, 13, 14, 15, 17, 19, 21T. |
| | 13, 14, 15, 17, 19, 21, 24T. |
| | 13, 14, 15, 16, 17, 19, 21T. |
| | 13, 15, 17, 19, 21, 23, 26T. |
| | 13, 15, 17, 19, 21, 24, 28T. |
| | 15, 16, 17, 18, 19, 20, 21T. |

Teeth	6-speed	7-speed
Threaded Sprockets	12—16T. (6S mark)	12—16T. (7S mark)
2nd Gear (Spline Type) w/Spacer	13T. (6S mark)	13T. (7S mark)
Spline Sprockets	14—26T./28T./30T./32T./34T.	
Spacer Width	3.65mm. (Light Gray)	2nd—3.30mm. (except 13T.) 3rd to low-3.15mm. (7S mark) (Dark Gray)

HG Chain
CN-HG90

Weight 326g. (110 Link)
Features Narrow Type HG Chain, Chrome Finish Link Pins
Size 1/2" x 3/32"
Material & Finish Black Finish (Roller Link Plate), Silver Finish (Pin Link Plate)

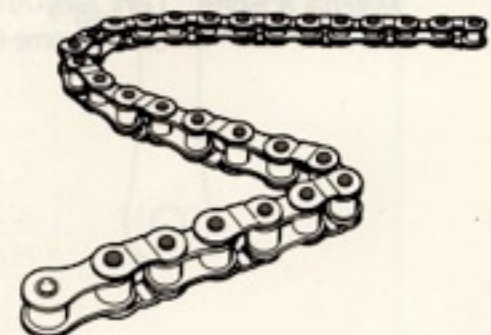

Pedal
PD-6400

- Weight** 478g. (Pair, Including Toe Clip Size L)
- Features** Positive Grip Shoe Creat. 34° Road Clearance, Easy-Maintenance Cartridge Axle, Compound Structure of Resin Bushing and Cup & Cone Bearings, Aerodynamic Design, Sealed Mechanism
- Material & Finish** Light Alloy (Body), Light Alloy-Anodized Finish (Front Plate), Cr-Mo Steel (Axle), Steel-Chrome-Plated or Light Alloy-Anodized Finish (Toe Clip)
- Toe Clip Size** M, L, LL
- Crank Thread** English BC 9/16" × 20TPI.

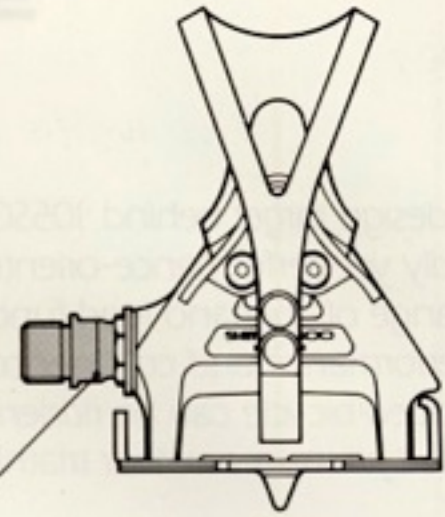

Cartridge Axle
Easy-Maintenance

Clipless Pedal
PD-6401

- Weight** 450g. (Pedal, Pair), 92g. (Cleat & Hard Wear)
- Features** 34° Road Clearance, Easy Maintenance Cartridge Axle, Aerodynamic Dustcapless Design, Efficient Sealed Mechanism, Adjustable Cleat Grip Tension, Compatible Look® Cleats, Low-Profile Design
- Material** Light Alloy (Body), Cr-Mo Steel (Axle)
- Crank Thread** English BC 9/16" × 20TPI.

Adjustable Cleat
Grip Tension

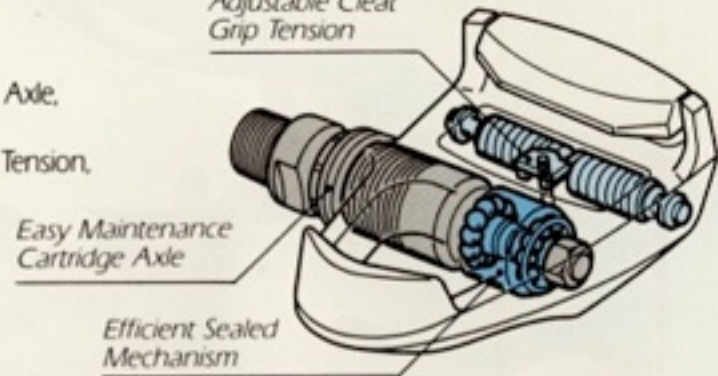

Easy Maintenance
Cartridge Axle

Efficient Sealed
Mechanism

Seat Pillar
SP-6400-A (Round Tube, A Type)
SP-6400-B (Semi Oval Tube, B Type)

- Weight** 284g. (B Type, 27.2mm.)
- Features** Aerodynamic Design, Hexagon Release
- Material & Finish** Light Alloy-Anodized Finish
- Shaft Adjustment Length** 25.0mm. — 27.2mm.

Hexagon Release

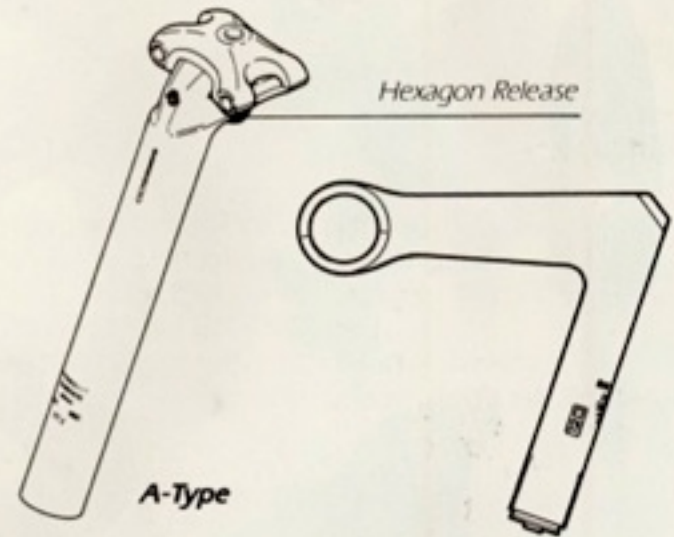

A-Type

Handle Stem
HS-6400

- Weight** 286g. (100mm.)
- Features** Aerodynamic Design, Hexagon Release
- Material & Finish** Light Alloy-Anodized Finish
- Extension** 80mm., 90mm., 100mm., 110mm., 120mm., 130mm.
- Handle Stem Diameter** 22.2mm.
- Handlebar Clamp Diameter** 25.4mm., 26.0mm.

Head Parts
HP-6400

- Weight** 100g.
- Features** Road Type, Compact & Light Weight, Sealed Mechanism, Burnished & Polished Finish
- Material & Finish** Light Alloy (Upper & Lower Cup), Cr-Mo Steel (Races), Stainless Steel (Lower Cone)
- Height Variation** Upper Cone 22.0mm., Lower Cone 11.5mm.

Dimensions

Type	Thread	Press Race Diameter	
		Upper Cone & Lower Cup	Lower Cone
English/Italian	BC1 × 24T.	30.2mm.	26.4mm.
French	M25 × P1.0	30.2mm.	26.4mm.

t_1	22.0mm.
t_2	11.5mm.
H	Head Tube Length
A	22.3mm.
B	30.2mm.
C	26.4mm.
Thread	BC 1" × 24T. (English Thread)/ M25" × P1.0 (French Thread)

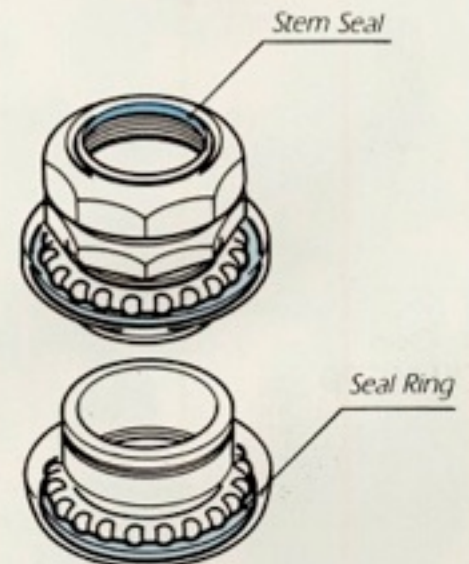
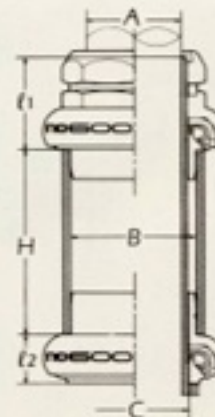

Stem Seal

Seal Ring

SHIMANO 105 SC

The design target behind 105SC was to create a sport cycling component group that provides a friendly yet performance-oriented feeling for a variety of cycling styles. The 105SC group offers a full range of Shimano road functions that allow cyclists of varying skill to ride with a greater feeling of performance and confidence. Shimano 105SC was designed to have wide appeal. The 105SC-equipped bicycle can be ridden and appreciated by everybody—from casual weekend riders to fitness cyclists to amateur triathletes.



Rear Derailleur
RD-1055

Weight	247g.
Compatibility	6 & 7-speed SIS Compatible
Features	Sealed Link Pivots, Sintered Alloy Guide Pulley Bushing, Sealed Pivot & Bracket Axle, Double Servo-Panta Mechanism, B-Tension Adjust Bolt, Double Spoke Barrier, Chain Retainer
Capacity	Maximum Rear Sprocket: 28T. Minimum Rear Sprocket: 12T. Front Difference: 13T. Total Capacity: 28T.
Material & Finish	Light Alloy•Enamel Finish (Bracket & Plate Body & Right Link), Steel•Pearl Bright Finish (Left Link)

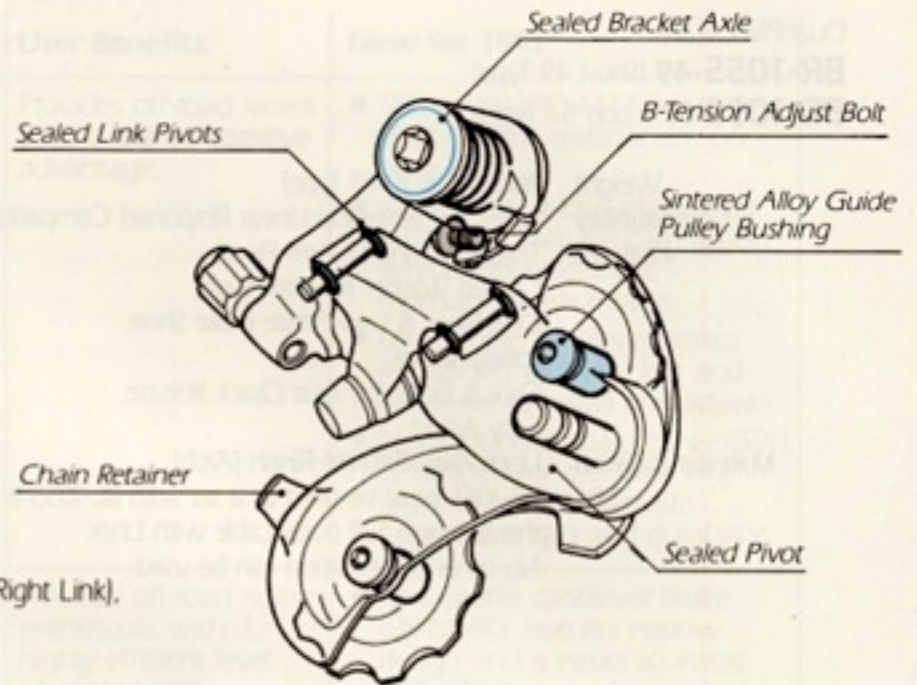

Front Derailleur
FD-1055-B (Band Type)
FD-1055-F (Italian Brazed-on A Type)

Weight	105g. (Band Type)
Compatibility	Shimano SG Compatible, Narrow Type Chain Compatible
Features	Leading Action Pantagraph Mechanism, Compact Design, Rigid Chain Guide,
Capacity	14T.
Clamp Diameter	28.0mm.—28.6mm.
Material & Finish	Light Alloy•Enamel Finish (Right Link, Front & Rear Band), Steel•Pearl Bright Finish (Chain Guide)

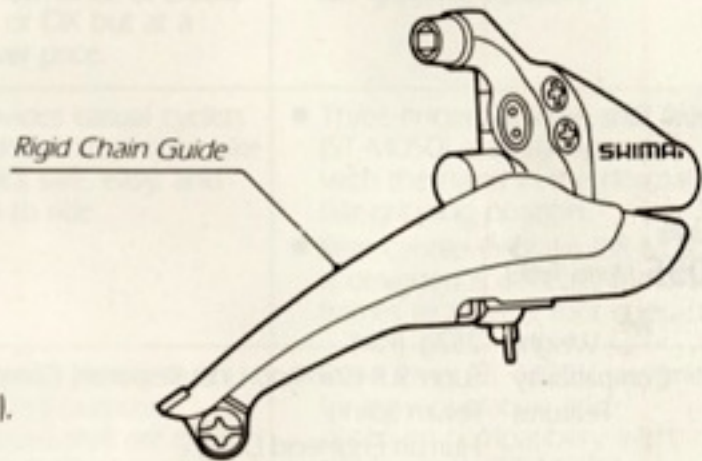

Shifting Lever
SL-1055-FCAI (7-speed SIS, Brazed-on A Type)
SL-1055-BCAI (7-speed SIS, Side Band A Type)
*“C” means Italian Type (Fixing Bolt is 5mm. Diameter)

Weight	70g. (SL-1055-FCAI)
Features	7-speed SIS, SIS-Friction Mode Switch, 30° Off-set of Lever Stopper (Front), Light Action Lever (Front), Sealed Mechanism, Human Engineered Design,
Type	Down Tube Lever
Lever Clamp Diameter	28.6mm.
Material & Finish	Light Alloy•Enamel Finish (Lever)

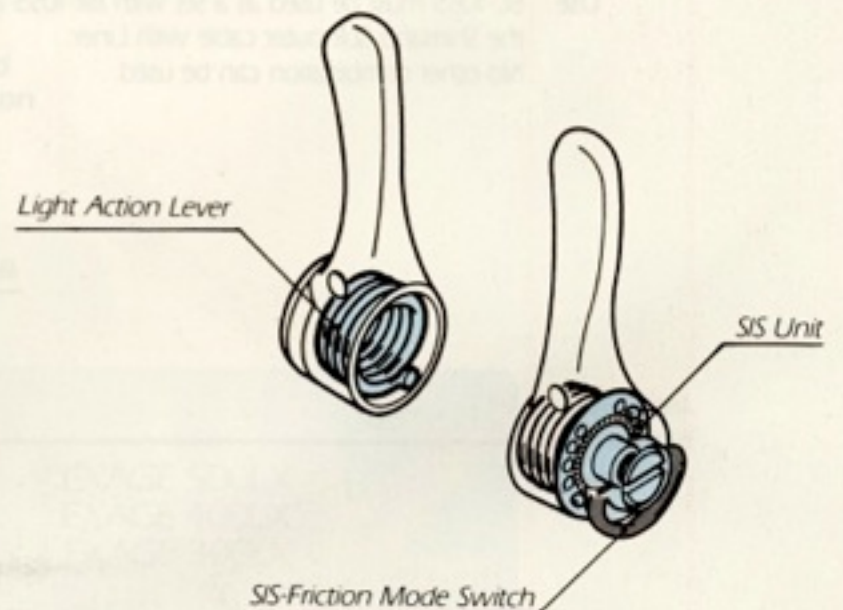

Dual Pivot Brake

BR-1055-49 (Short 49 Type)

BR-1055-57 (Long 57 Type)

Weight 360g. (F & R, 49 Type)
Compatibility Super SLR (Shimano Linear Response) Compatible
Features Thrust Bearing (Y-Arm Pivot),
 Coated Washer (C-Arm Pivot),
 One-Piece & Low Profile Brake Shoe,
 Spring Sleeve,
 Click & Eccentric Type Quick Release,
 Easy Adjust

Material & Finish Light Alloy•Enamel Finish (Arch).
Use BR-1055 must be used as a set with BL-1055 and
 the Shimano SLR outer cable with Liner.
 No other combination can be used.

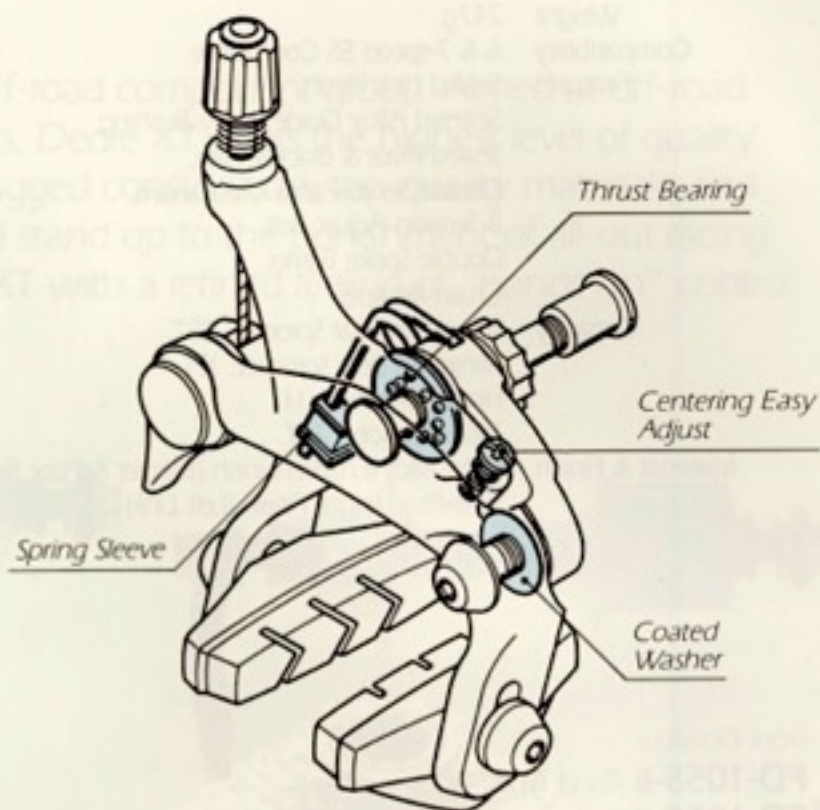

Brake Lever

BL-1055 (Aero Type)

Weight 252g. (Pair)
Compatibility Super-SLR (Shimano Liner Response) Compatible
Features Return Spring,
 Human Engineerd Design,
 Aerodynamic Design

Lever Clamp Diameter 23.8mm.—24.2mm.
Lever Stroke 84mm.

Light Alloy•Enamel Finish (Lever),
 Light Alloy•Barrel Finish (Bracket),
 Soft Resin (Cover)

Color (Bracket Cover) Black, White

Use BL-1055 must be used as a set with BR-1055 and
 the Shimano SLR outer cable with Liner.
 No other combination can be used.

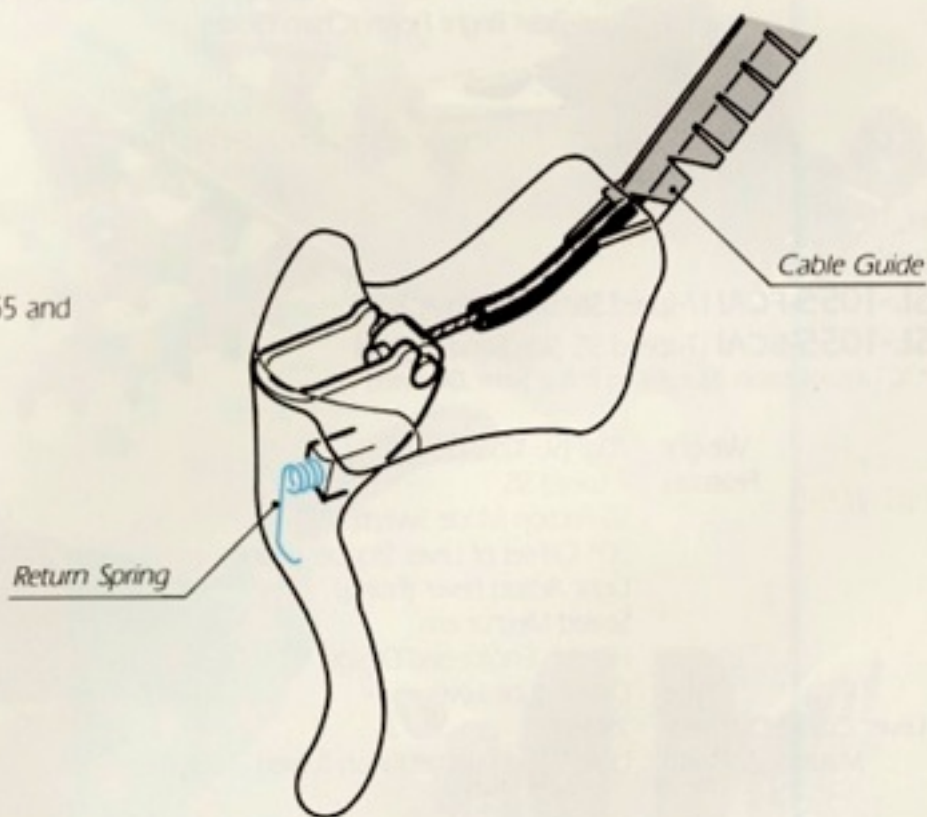

Front Chainwheel & Bottom Bracket Assembly
FC-1055-SG (Shimano SG Double, LD Type)
BB-1055 (B.B. Set)

Weight	710g. (42T, 52T, 170mm.), 340g. (B.B. Set)
Compatibility	Narrow Type Chain Compatible
Features	Shimano SG Gear, Sealed Mechanism (B.B.)
Use	For 1/2" x 3/32" Chain
Teeth Combination	52 x 42 (Biopace SG), 53 x 42, 52 x 42 (Shimano SG)
Crank Length	165mm., 167.5mm., 170mm., 172.5mm., 175mm.
Crank Thread	English BC 9/16" x 20T.P.I.
Cup Thread	English BC 1.37 x 24T.P.I., French M35 x 1.0, Italian M36 x 24T.P.I.
B.B. Size	70-W-115, 68-W-113
Material & Finish	Light Alloy•Enamel Finish (Crank), Light Alloy•Anodized Finish (Chaining), Nickel Cr-Mo Axle

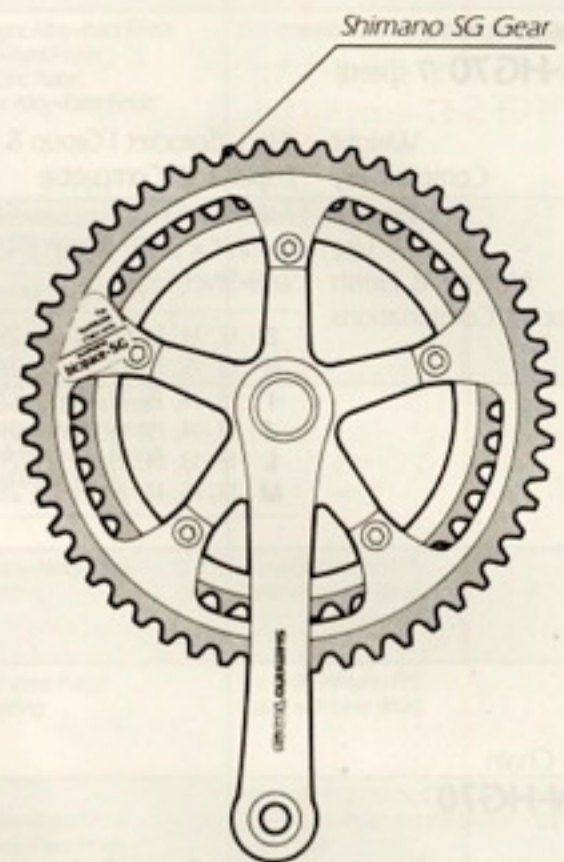

Freehub
FH-1055-HG (7-speed)

Weight	415g. (w/Quick Release)
Compatibility	7-speed SIS Compatible
Features	HG/UG Convertible Type, Lip Type Sealed Mechanism, Uni-Balance System, One-Piece Forged Hub Body
Over Lock Nut Dimensions	126mm.
Axle Length	137mm.
Axle Thread	M10
Spoke Holes	32H, 36H
Hole PCD	45
Chain Line	41.2mm.
Material & Finish	Light Alloy•Anodized Finish (Hub Shell)

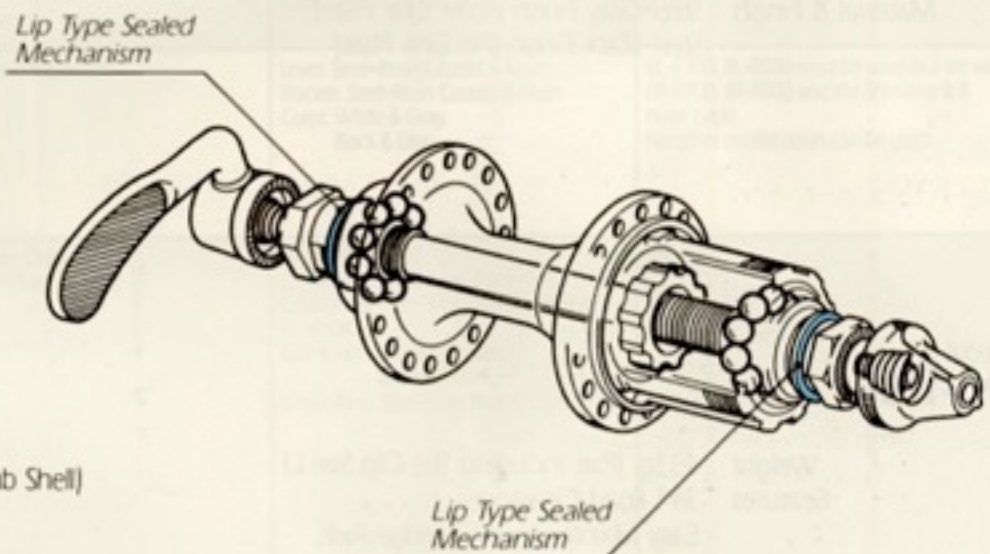

Front Hub
HB-1055-F

Weight	216g. (with Quick Release)
Features	Lip Type Sealed Mechanism, One-Piece Forged Hub Body
Over Lock Nut Dimensions	100mm., 96mm.
Axle Length	108mm., 104mm.
Axle Thread	M9
Spoke Holes	32H, 36H
Hole PCD	38
Material & Finish	Light Alloy•Anodized Finish (Hub Shell)

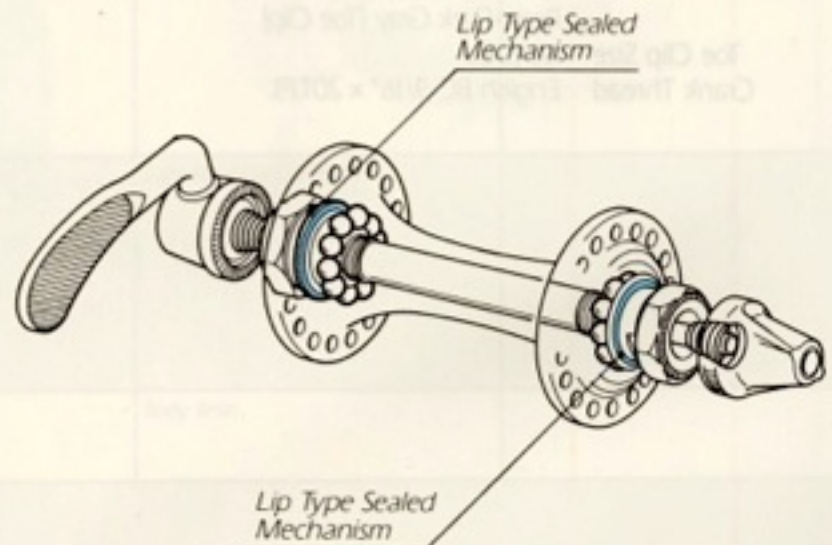

Cassette Sprockets

CS-HG70 (7-speed)

Weight 286g. (Sprocket 1 Group & Spacer)
 Compatibility 7-speed SIS Compatible
 Feature 7-speed HG
 Use For 1/2" x 3/32" Chain (Narrow Type Chain)
 Material & Finish Steel•Silver Finish

Sprocket Combinations

E	12, 14, 16, 18, 21, 24, 28T.
H	13, 15, 17, 19, 21, 23, 26T.
I	13, 14, 15, 17, 19, 21, 23T.
J	13, 14, 15, 16, 17, 19, 21T.
L	12, 13, 14, 15, 17, 19, 21T.
M	13, 15, 17, 19, 21, 24, 28T.

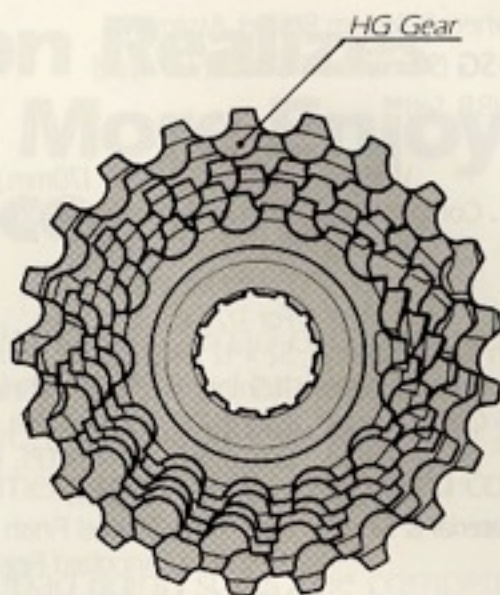

HG Chain
CN-HG70

Features Narrow Type HG Chain,
 Chromed Finished Link Pins
 Size 1/2" x 3/32"
 Material & Finish Steel•Gray Finish (Roller Link Plate),
 Steel•Black Finish (Pin Link Plate)

Chromed Finished Link Pins

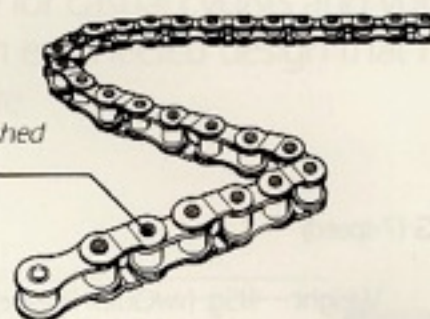

Pedal
PD-1055

Weight 433g. (Pair, Including Toe Clip Size L)
 Features 34° Road Clearance,
 Easy Maintenance Cartridge Axle,
 Aerodynamic Design,
 Sealed Mechanism
 Material Light Alloy (Body),
 Steel (Front Plate),
 Cr-Mo Steel (Axle),
 Resin•Dark Gray (Toe Clip)
 Toe Clip Size M, L, LL
 Crank Thread English BC 9/16" x 20T.P.I.

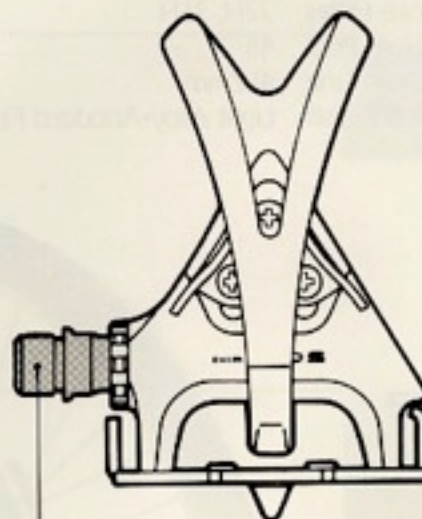

Easy Maintenance Cartridge Axle

Clipless Pedal
PD-1056

- Weight** 460g. (Pedal, Pair), 105g. (Cleat & Hard Wear)
- Features** 34° Road Clearance,
Two Release Modes,
Easy Maintenance Cartridge Axle,
Aerodynamic Dastcap-less Design,
Adjustable Cleat Grip Tension,
Sealed Mechanism,
Low-Profile Design,
Compatible Look® Cleats
- Material** Ligh Alloy (Body),
Cr-Mo Steel
- Crank Thread** English BC 9/16" x 20TPI.

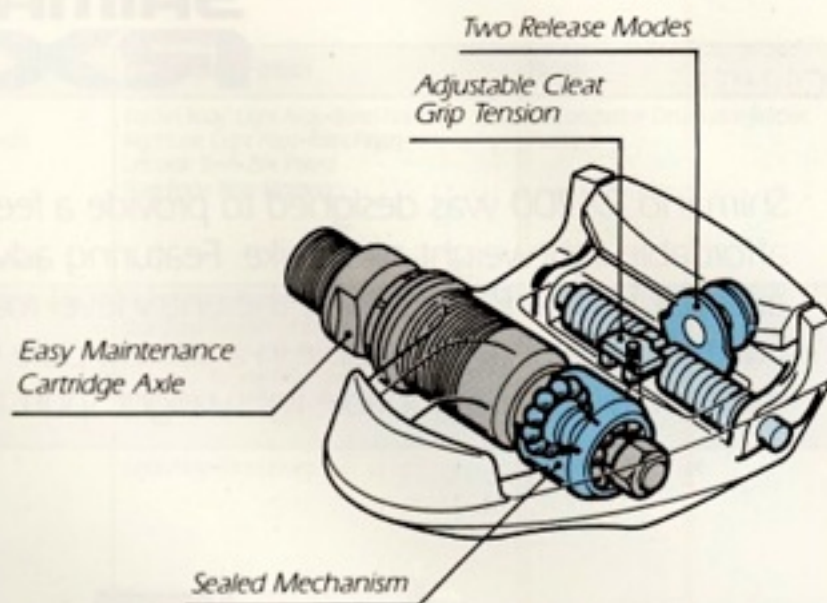

Head Parts
HP-1055

- Weight** 101g.
- Type** Road Type
- Feature** Sealed Mechanism
- Material & Finish** Light Alloy•Silver Finish (Upper & Lower Cup),
Cr-Mo Steel (Races),
Stainless Steel (Lower Cone)
- Height Variation** Upper Cone 21.2mm., Lower Cone 11.5mm.

Type	Thread	Press Race Diameter	
		Upper Cone & Lower Cup	Lower Cone
English/Italian	BC1 x 24T.	30.2mm.	26.4mm.
French	M25 x P1.0	30.2mm.	26.4mm.

Dimensions

t ₁	21.2mm.
t ₂	11.5mm.
H	Head Tube Length
A	22.3mm.
B	30.2mm.
C	26.4mm.
Thread	BC 1" x 24T. (English Thread)/ M25" x P1.0 (French Thread)

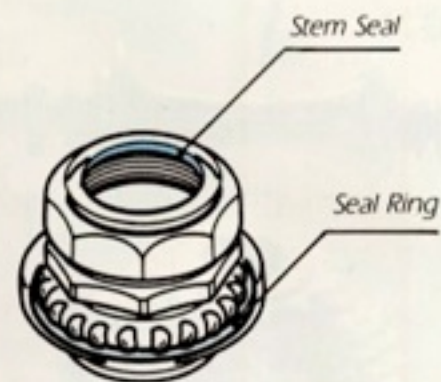
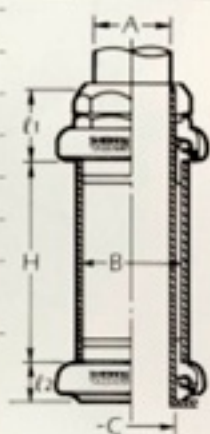

SHIMANO RX100

Shimano RX-100 was designed to provide a feeling of both style and high performance to the affordable lightweight sport bike. Featuring advanced Shimano functions like SIS, HG sprockets, and SLR brakes, RX-100 gives the entry level road bike the potential for performance in the Shimano tradition. Optionally available in a striking pure white color treatment, Shimano RX-100 components make possible a fashionable lightweight sport bike that's as beautiful as it is affordable.



Shimano RX100

Model No.	Specifications	Features	Material • Finish	Note																
Rear Derailleur RD-A550	6 & 7-speed SIS Compatible Max. Rear Sprocket: 28T. Min. Rear Sprocket: 12T. Front Difference: 13T. Total Capacity: 28T. 280g.	Double Servo-Panta Mechanism Centeron Guide Pulley Double Spoke Barrier B-Tension Adjuster Sealed Pivot Axle Sealed Link Pivot Sintered Alloy Guide Pulley Bushing	Bracket Body: Light Alloy • Barrel Finish Right Link: Light Alloy • Barrel Finish Left Link: Steel • Pearl Bright Finish Plate Body: Light Alloy • Barrel Finish	SIS Compatible Detachable Bracket Available																
Front Derailleur FD-A550-B (Band Type) FD-A550-F (Italian Type)	Capacity: 14T. Band Diameter: $\phi 28.0\text{mm}$ — $\phi 28.6\text{mm}$. Stroke (w/ $\phi 28.6\text{mm}$ Band): 37 — 51 Narrow Type Chain Compatible 100g. (Band Type)	Leading Action Pantagraph Mechanism Rigid Chainguide Compact Design	Front Band: Light Alloy • Barrel Finish Rear Band: Light Alloy • Barrel Finish Right Link: Light Alloy • Barrel Finish Chainguide: Steel • Pearl Bright Finish	Brazed-on Type Available																
Shifting Lever SL-A550-FCAI (Brazed-on A Type) SL-A550-BCAI (Side Band A Type)	7-speed SIS Down Tube Lever Lever Clamp Diameter: 28.6mm. 72g. (SL-A550-FCAI)	SIS-Friction Mode Switch Light Action Lever Sealed Mechanism 30° Off set of Lever Stopper	Light Alloy • Barrel Finish	(C) means Italian Type Fixing Bolt is 5mm Diameter																
Dual Pivot Brake BR-A550-49 (Short 49 Type) BR-A550-57 (Long 57 Type)	Super-SLR (Shimano Linear Response) Compatible Sunken Bolt type Front: 27.5mm. Rear: 12.8mm. Nut Type Front: 47.0mm. Rear: 30.0mm. 348g. (F & R 49 Type)	Easy Adjust With Synchronizer Spring Sleeve Coated Pivot Washer One Piece & Low Profile Brake Shoe	C-Arm: Light Alloy • Anodized Finish Y-Arm: Light Alloy • Anodized Finish Gate: Light Alloy • Anodized Finish	BR-A550 must be used as a set with BL-A550 and the Shimano SLR outer cable. No other combination can be used.																
Brake Lever BL-A550 (Aero Type)	Super-SLR (Shimano Linear Response) Compatible Lever Clamp Diameter: 23.8mm. — 24.2mm. Lever Stroke: 84 252g. (Pair)	Aerodynamic Design	Lever: Light Alloy • Anodized Finish Bracket: Light Alloy • Barrel Finish Cover: Soft Resin • Molding Back: White	BL-A550 must be used as a set with BR-A550 and the Shimano SLR outer cable. No other combination can be used.																
Front Chainwheel FC-A550-SG (Shimano SG Double, LD Type) FC-A550-BP (Biopace Double, LD Type) Bottom Bracket Assembly BB-A550 BB-UN10	Narrow Type Chain Compatible Crank Length: 165mm., 170mm. Teeth: 52 x 42T. (Biopace SG). 53 x 42T., 52 x 42T. (Shimano SG) Crank Thread: English BC 9/16" x 20T.P.I. Crank Thread: English BC 1.37 x 24T.P.I. French M35 x 1.0. Italian M36 x 24T.P.I. 700g. (42T., 52T., 170mm.) 327g. (BB. Set)	Sealed Mechanism (BB.)	Crank Arm: Light Alloy • Barrel Finish Chain Ring: Light Alloy • Anodized Finish	Spindle: <table border="1"> <thead> <tr> <th></th> <th>BB-A450</th> <th>BB-UN10</th> </tr> </thead> <tbody> <tr> <td>Mark</td> <td>SH</td> <td>3H</td> </tr> <tr> <td>Width</td> <td>70</td> <td>68</td> </tr> <tr> <td>Length</td> <td>115</td> <td>113</td> </tr> </tbody> </table>		BB-A450	BB-UN10	Mark	SH	3H	Width	70	68	Length	115	113				
	BB-A450	BB-UN10																		
Mark	SH	3H																		
Width	70	68																		
Length	115	113																		
Freehub FH-A550	7-speed SIS Compatible UG/HG Compatible Type Spoke Holes: 36H., 32H. Hole PCD: 45 <table border="1"> <tr> <td>OLD</td> <td>126</td> </tr> <tr> <td>Axle Length</td> <td>137</td> </tr> <tr> <td>Mounting Type</td> <td>Quick Release</td> </tr> </table> Axle Thread: 10mm. 420g. (7-speed w/Quick Release)	OLD	126	Axle Length	137	Mounting Type	Quick Release	Uni-Balance System Resin Sealed Mechanism One-Piece Forged Hub Body	Light Alloy • Polish Finish											
OLD	126																			
Axle Length	137																			
Mounting Type	Quick Release																			
Front Hub HB-A550-F	Spoke Holes: 36H., 32H. Hole PCD: 38 <table border="1"> <tr> <td>O.L.D.</td> <td>100</td> <td>96</td> </tr> <tr> <td>Axle Length</td> <td>108</td> <td>104</td> </tr> <tr> <td>Mounting Type</td> <td colspan="2">Quick Release</td> </tr> </table> Axle Thread: 9mm 202g.	O.L.D.	100	96	Axle Length	108	104	Mounting Type	Quick Release		Resin Sealed Mechanism One-Piece Forged Hub Body	Light Alloy • Polish Finish								
O.L.D.	100	96																		
Axle Length	108	104																		
Mounting Type	Quick Release																			
Cassette Sprockets CS-HG70 (7-Speed)	7-speed SIS Compatible 7-speed HG Gear Use Narrow Type Chain 325g. (Sprocket I Group)		Steel • Silver Finish	Cassette Sprocket Combinations: J 13, 14, 15, 16, 17, 19, 21T. I 13, 14, 15, 17, 19, 21, 23T. H 13, 15, 17, 19, 21, 23, 26T. M 13, 15, 17, 19, 21, 24, 28T. L 12, 13, 14, 15, 17, 19, 21T. E 12, 14, 16, 18, 21, 24, 28T.																
Chain CN-HG70	7-speed SIS Compatible 7-speed HG Compatible Narrow Type Chain (1/2" x 3/32") 337g. (114 Link)	Chrome finish Link Pin Connecting Pin Bushings Design	Roller Link Plate: Steel • Gray Finish Pin Link Plate: Steel • Black Finish																	
Pedal PD-A550	Crank Thread: English BC 9/16" x 20T.P.I. Toe Clip Size: M, L, LL Top Clip Locking System: 3-screw 400g. (Pair, Including Toe Clip Size L)	32° Road Clearance Easy-Maintenance Cartridge Axle Sealed Mechanism Aerodynamic Design Reflector (Option)	Body: Light Alloy • Barrel Finish Toe Clip: Resin																	
Head Parts HP-R500	Height: Upper Cone 22.0mm. Lower Cone 11.5mm. 121g. Variation: <table border="1"> <thead> <tr> <th colspan="4">Press Race Diameter</th> </tr> <tr> <th></th> <th></th> <th>Upper Cone & Lower Cup</th> <th>Lower Cone</th> </tr> </thead> <tbody> <tr> <td>English/Italian</td> <td>BC1 x 24T</td> <td>30.2mm.</td> <td>26.4mm.</td> </tr> <tr> <td>French</td> <td>M25 x P1.0</td> <td>30.2mm.</td> <td>26.4mm.</td> </tr> </tbody> </table>	Press Race Diameter						Upper Cone & Lower Cup	Lower Cone	English/Italian	BC1 x 24T	30.2mm.	26.4mm.	French	M25 x P1.0	30.2mm.	26.4mm.	Sealed Mechanism	Lock Nut: Steel • Pearl Bright Finish Upper Cup: Resin Lower Cup: Resin Color: White, Silver, Black	
Press Race Diameter																				
		Upper Cone & Lower Cup	Lower Cone																	
English/Italian	BC1 x 24T	30.2mm.	26.4mm.																	
French	M25 x P1.0	30.2mm.	26.4mm.																	

EXAGE EX

Shimano RX100



Exage 500EX

Exage 500EX

Model No.	Specifications	Features	Material • Finish	Note																
Rear Derailleur RD-A500	6 & 7-speed SS Compatible Max. Rear Sprocket: 28T. Min. Rear Sprocket: 12T. Front Difference: 13T. Total Capacity: 28T. 279g	Double Servo-Panta Mechanism Centeron Guide Pulley Double Spoke Barrier B-Tension Adjuster Sealed Mechanism Sintered Alloy Guide Pulley Bushing	Bracket Body: Light Alloy • Paint Finish Right Link: Light Alloy • Paint Finish Left Link: Steel • Pearl Bright Finish Plate Body: Light Alloy • Paint Finish	SS Compatible Detachable Bracket Available																
Front Derailleur FD-A500-B (Band Type) FD-A500-F (Italian Type)	Capacity: 14T. Band Diameter: $\phi 28.0\text{mm}$ — $\phi 28.6\text{mm}$. Stroke (w/ $\phi 28.6\text{mm}$ Band): 37 – 51 Narrow Type Chain Compatible 115g (Band Type)	Leading Action Pantograph Mechanism Rigid Chainguide Compact Design	Front Band: Steel • Paint Finish Rear Band: Light Alloy • Paint Finish Right Link: Light Alloy • Paint Finish Chainguide: Chrome Plated	Brazed-on Type Available																
Shifting Lever SL-A500-FCAI (Brazed-on A Type) SL-A500-BCAI (Side Band A Type)	7-speed SS Down Tube Lever Lever Clamp Diameter: 28.6mm. 76g (SL-A500-FCAI)	SS-Friction Mode Switch Light Action Lever Sealed Mechanism	Light Alloy • Paint Finish	(C) means Italian Type Fixing Bolt is 5mm Diameter																
Dual Pivot Brake BR-A500-49 (Short 49 Type) BR-A500-57 (Long 57 Type)	Super-SLR (Shimano Linear Response) Compatible Sunken Bolt type Front: 27.5mm. Rear: 12.8mm. Nut Type Front: 47.0mm. Rear: 30.0mm. 326g (F & R, 49 Type)	Easy Adjust With Synchronizer Spring Sleeve Coated Pivot Washer One Piece & Low Profile Brake Shoe	C-Arm: Light Alloy • Paint Finish Y-Arm: Light Alloy • Paint Finish Gate: Light Alloy • Barrel Finish	BR-A500 must be used as a set with BL-A500 and the Shimano SLR outer cable. No other combination can be used.																
Brake Lever BL-A500 (Aero Type)	Super-SLR (Shimano Linear Response) Compatible Lever Clamp Diameter: 23.8mm. — 24.2mm. Lever Stroke: 84 258g (BL-A500, Pair)	Aerodynamic Design	Lever: Light Alloy • Anodized Finish Bracket: Light Alloy • Barrel Finish Cover: Soft Resin • Molding Black, White	BL-A500 must be used as a set with BR-A500 and the Shimano SLR outer cable. No other combination can be used.																
Front Chainwheel FC-A500-BP (Biopace Double, LD Type) Bottom Bracket Assembly BB-A450 BB-UN10	Narrow Type Chain Compatible Crank Length: 165mm., 170mm. Teeth: Top 50T, 52T, 53T. Low 40T, 42T Crank Thread: English BC 9/16" x 20TPI. Crank Thread: English BC 1.37 x 24TPI. French M35 x 1.0. Italian M36 x 24TPI. 720g (42T, 52T, 170mm.) 333g (B.B. Set)	Sealed Mechanism (BB)	Crank Arm: Light Alloy • Barrel Finish Chain Ring: Light Alloy • Anodized Finish	Spindle: <table border="1"> <thead> <tr> <th></th> <th>BB-A450</th> <th>BB-UN10</th> </tr> </thead> <tbody> <tr> <td>Mark</td> <td>5H 3H</td> <td>DH</td> </tr> <tr> <td>Width</td> <td>70</td> <td>68</td> </tr> <tr> <td>Length</td> <td>115</td> <td>113</td> </tr> </tbody> </table>		BB-A450	BB-UN10	Mark	5H 3H	DH	Width	70	68	Length	115	113				
	BB-A450	BB-UN10																		
Mark	5H 3H	DH																		
Width	70	68																		
Length	115	113																		
Freehub FH-HG50	7-speed SS Compatible UG/HG Compatible Type Spoke Holes: 36H., 32H. Hole PCD: 45 <table border="1"> <tr> <td>O.L.D.</td> <td>135</td> <td>130</td> <td>126</td> </tr> <tr> <td>Axle Length</td> <td>146</td> <td>141</td> <td>137</td> </tr> <tr> <td>Mounting Type</td> <td>Quick Release</td> <td colspan="2">Nut</td> </tr> </table> Axle Thread: 10mm 435g (7-speed w/Quick Release)	O.L.D.	135	130	126	Axle Length	146	141	137	Mounting Type	Quick Release	Nut		Uni-Balance System Resin Sealed Mechanism (Choice) One-Piece Forged Hub Body	Light Alloy • Dia-Cut Finish					
O.L.D.	135	130	126																	
Axle Length	146	141	137																	
Mounting Type	Quick Release	Nut																		
Front Hub HB-RM50-F	Spoke Holes: 36H., 32H. Hole PCD: 38 <table border="1"> <tr> <td>O.L.D.</td> <td>100</td> <td>96</td> </tr> <tr> <td>Axle Length</td> <td>108</td> <td>104</td> </tr> <tr> <td>Mounting Type</td> <td colspan="2">Quick Release</td> </tr> </table> Axle Thread: 9mm 228g	O.L.D.	100	96	Axle Length	108	104	Mounting Type	Quick Release		Resin Sealed Mechanism (Choice) One-Piece Forged Hub Body	Light Alloy • Dia-Cut Finish								
O.L.D.	100	96																		
Axle Length	108	104																		
Mounting Type	Quick Release																			
Cassette Sprockets CS-HG50 (7-Speed)	7-speed SS Compatible 7-speed HG Use Narrow Type Chain 268g. (Sprocket I Group)		Steel • Brown Finish & Silver Finish (Low Gear)	Cassette Sprocket Combinations: J 13, 14, 15, 16, 17, 19, 21T. I 13, 14, 15, 17, 19, 21, 23T. H 13, 15, 17, 19, 21, 23, 26T. M 13, 15, 17, 19, 21, 24, 28T. L 12, 13, 14, 15, 17, 19, 21T. E 12, 14, 16, 18, 21, 24, 28T.																
Chain CN-HG50	7-speed SS Compatible 7-speed HG Compatible Narrow Type Chain (1/2" x 3/32") 335g. (114 Link)	Chrome Finish Link Pin Connecting Pin Bushingsless Design	Roller Link Plate: Steel • Black Finish Pin Link Plate: Steel • Black Finish																	
Pedal PD-A550	Crank Thread: English BC 9/16" x 20TPI. Toe Clip Size: M, L, LL Top Clip Locking System: 3-screw 407g. (Pair, Including Toe Clip Size L)	32° Road Clearance Easy-Maintenance Cartridge Axle Sealed Mechanism Aerodynamic Design Reflector (Option)	Plate & Body: Light Alloy • Barrel Finish Toe Clip: Resin																	
Head Parts HP-R500	Height: Upper Cone 22.0mm. Lower Cone 11.5mm. 121g Variation: <table border="1"> <thead> <tr> <th colspan="2"></th> <th colspan="2">Press Race Diameter</th> </tr> <tr> <th colspan="2"></th> <th>Upper Cone & Lower Cup</th> <th>Lower Cone</th> </tr> </thead> <tbody> <tr> <td>English/Italian</td> <td>BC1 x 24T</td> <td>30.2mm.</td> <td>26.4mm.</td> </tr> <tr> <td>French</td> <td>M25 x P1.0</td> <td>30.2mm.</td> <td>26.4mm.</td> </tr> </tbody> </table>			Press Race Diameter				Upper Cone & Lower Cup	Lower Cone	English/Italian	BC1 x 24T	30.2mm.	26.4mm.	French	M25 x P1.0	30.2mm.	26.4mm.	Sealed Mechanism	Lock Nut: Steel • Pearl Bright Finish Upper Cup: Resin Lower Cup: Resin Color: White, Silver, Black	
		Press Race Diameter																		
		Upper Cone & Lower Cup	Lower Cone																	
English/Italian	BC1 x 24T	30.2mm.	26.4mm.																	
French	M25 x P1.0	30.2mm.	26.4mm.																	

Exage 400EX

EXAGE EX

Model No.	Specifications	Features	Material • Finish	Note																
Rear Derailleur RD-A400	6 & 7-speed SIS Compatible Max. Rear Sprocket: 28T. Min. Rear Sprocket: 12T. Front Difference: 13T. Total Capacity: 28T. 278g.	Double Servo-Panta Mechanism Centeron Guide Pulley Double Spoke Barrier B-Tension Adjuster Sealed Mechanism Sintered Alloy Guide Pulley Bushing	Bracket Body: Light Alloy • Barrel Finish Right Link: Steel • Paint Finish Left Link: Steel • Zinc plated Plate Body: Light Alloy • Barrel Finish	SIS Compatible Detachable Bracket Available																
Front Derailleur FD-A400-B (Band Type) FD-A400-F (Italian Type)	Capacity: 14T Band Diameter: ϕ 28.0mm. — ϕ 28.6mm. Stroke (w/ ϕ 28.6mm. Band): 37 ~ 51 Narrow Type Chain Compatible 113g. (Band Type)	Leading Action Pantograph Mechanism Rigid Chainguide Compact Design	Front Band: Steel • Pearl Bright Finish Rear Band: Light Alloy • Barrel Finish Right Link: Light Alloy • Paint Finish Chainguide: Chrome Plated	Brazed-on Type Available																
Shifting Lever SL-A400-FCAI (Blazed-on A Type) SL-A400-BCAI (Side Band A Type)	7-speed SIS Down Tube Lever Lever Clamp Diameter: 28.6mm. 71g. (SL-A400-FCAI)	SIS-Friction Mode Switch Light Action Lever Sealed Mechanism	Light Alloy • Barrel Finish	(C) means Italian Type Fixing Bolt is 5mm Diameter																
Caliper Brake BR-A350-49 (Short 49 Type) BR-A350-57 (Long 57 Type)	SLR (Shimano Linear Response) Compatible Sunken Bolt type Front: 27.5mm. Rear: 12.8mm. Nut Type Front: 47mm. Rear: 30.0mm. 310g. (F & R, 49 Type)	Spring Sleeve Coated Pivot Washer One Piece & Low Profile Brake Shoe	C-Arm: Light Alloy • Paint Finish Y-Arm: Light Alloy • Paint Finish	For SLR System use with SLR compatible brake lever and Shimano outer cable with liner.																
Brake Lever BL-A351 (Aero Type)	SLR (Shimano Linear Response) Compatible Lever Clamp Diameter: 23.8mm. — 24.2mm. Lever Stroke: 88 302g. (BL-A351, Pair)	With Quick Release Aerodynamic Design	Lever: Light Alloy • Anodized Finish Bracket: Steel • Zinc Plated Cover: Soft Resin • Molding Black, White	For SLR System use with SLR compatible brake and Shimano outer cable with liner.																
Front Chainwheel FC-A400-BP (Biopace Double, LD Type) Bottom Bracket Assembly BB-A450 BB-UN10	Narrow Type Chain Compatible Crank Length: 165mm., 170mm. Teeth: Top 52T. Low 42T. Crank Thread: English BC 9/16" x 20T.P.I. Crank Thread: English BC 1.37 x 24T.P.I. French M35 x 1.0. Italian M36 x 24T.P.I. 920g. (42T, 52T, 170mm.) 333g. (BB Set)	Sealed Mechanism (BB)	Crank Arm: Light Alloy • Barrel Finish Chain Ring: Steel • Paint Finish	Spindle: <table border="1" style="margin-left: 20px;"> <tr> <td></td> <td>BB-A450</td> <td>BB-UN10</td> </tr> <tr> <td>Mark</td> <td>5H</td> <td>3H</td> </tr> <tr> <td>Width</td> <td>70</td> <td>68</td> </tr> <tr> <td>Length</td> <td>115</td> <td>115</td> </tr> </table>		BB-A450	BB-UN10	Mark	5H	3H	Width	70	68	Length	115	115				
	BB-A450	BB-UN10																		
Mark	5H	3H																		
Width	70	68																		
Length	115	115																		
Freehub FH-HG50	7-speed SIS Compatible UG/HG Compatible Type Spoke Holes: 36H., 32H. Hole PCD: 45 <table border="1" style="margin-left: 20px;"> <tr> <td>O.L.D.</td> <td>135</td> <td>130</td> <td>126</td> </tr> <tr> <td>Axle Length</td> <td>146</td> <td>141</td> <td>137</td> </tr> <tr> <td>Mounting Type</td> <td>Quick Release</td> <td>Nut</td> <td></td> </tr> </table> Axle Thread: 10mm. 435g. (7-speed w/Quick Release)	O.L.D.	135	130	126	Axle Length	146	141	137	Mounting Type	Quick Release	Nut		Uni-Balance System Resin Sealed Mechanism (Choice) One-Piece Forged Hub Body	Light Alloy • Dia-Cut Finish					
O.L.D.	135	130	126																	
Axle Length	146	141	137																	
Mounting Type	Quick Release	Nut																		
Front Hub HB-RM50-F	Spoke Holes: 36H., 32H. Hole PCD: 38 <table border="1" style="margin-left: 20px;"> <tr> <td>O.L.D.</td> <td>100</td> <td>96</td> </tr> <tr> <td>Axle Length</td> <td>108</td> <td>104</td> </tr> <tr> <td>Mounting Type</td> <td>Quick Release</td> <td></td> </tr> </table> Axle Thread: 9mm 228g.	O.L.D.	100	96	Axle Length	108	104	Mounting Type	Quick Release		Resin Sealed Mechanism (Choice) One-Piece Forged Hub Body	Light Alloy • Dia-Cut Finish								
O.L.D.	100	96																		
Axle Length	108	104																		
Mounting Type	Quick Release																			
Cassette Sprockets CS-HG50 (7-Speed)	7-speed SIS Compatible 7-speed HG Use Narrow Type Chain 268g. (Sprocket I Group)		Steel • Brown Finish & Silver Finish (Low Gear)	Cassette Sprocket Combinations: J 13, 14, 15, 16, 17, 19, 21T. I 13, 14, 15, 17, 19, 21, 23T. H 13, 15, 17, 19, 21, 23, 26T. M 13, 15, 17, 19, 21, 24, 28T. L 12, 13, 14, 15, 17, 19, 21T. E 12, 14, 16, 18, 21, 24, 28T.																
Chain CN-HG50	7-speed SIS Compatible 7-speed HG Compatible Narrow Type Chain (1/2" x 3/32") 335g. (114 Link)	Chrome finish Link Pin Connecting Pin Bushingsless Design	Roller Link Plate: Steel • Black Finish Pin Link Plate: Steel • Black Finish																	
Pedal PD-A550	Crank thread: English BC 9/16" x T.P.I. Toe Clip Size: M, L, LL Top Clip Locking System: 3-screw 407g. (Pair, Including Toe Clip Size L)	32° Road Clearance Easy-Maintenance Cartridge Axle Sealed Mechanism Aerodynamic Design Reflector (Option)	Plate & Body: Light Alloy • Barrel Finish Toe Clip: Resin																	
Head Parts HP-R500	Height: Upper Cone 22.0mm. Lower Cone 11.5mm. 121g. Variation: <table border="1" style="margin-left: 20px;"> <tr> <td></td> <td></td> <td colspan="2">Press Race Diameter</td> </tr> <tr> <td></td> <td></td> <td>Upper Cone & Lower Cup</td> <td>Lower Cone</td> </tr> <tr> <td>English/Italian</td> <td>BC1 x 24T</td> <td>30.2mm.</td> <td>26.4mm.</td> </tr> <tr> <td>French</td> <td>M25 x P1.0</td> <td>30.2mm.</td> <td>26.4mm.</td> </tr> </table>			Press Race Diameter				Upper Cone & Lower Cup	Lower Cone	English/Italian	BC1 x 24T	30.2mm.	26.4mm.	French	M25 x P1.0	30.2mm.	26.4mm.	Sealed Mechanism	Lock Nut: Steel • Pearl Bright Finish Upper Cup: Resin Lower Cup: Resin Color: White, Silver, Black	
		Press Race Diameter																		
		Upper Cone & Lower Cup	Lower Cone																	
English/Italian	BC1 x 24T	30.2mm.	26.4mm.																	
French	M25 x P1.0	30.2mm.	26.4mm.																	

Exage 300EX

Model No.	Specifications	Features	Material • Finish	Note																
Rear Derailleur RD-A300	6 & 7-speed SIS Compatible Max. Rear Sprocket: 28T. Min. Rear Sprocket: 12T. Front Difference: 13T. Total Capacity: 28T. 282g.	Cable Saver Arm Double Servo-Panta Mechanism Centeron Guide Pulley Double Spoke Barrier B-Tension Adjuster Sealed Mechanism Sintered Alloy Guide Pulley Bushing	Bracket Body: Light Alloy • Barrel Finish Right Link: Light Alloy • Paint Finish Left Link: Steel • Zinc Plated Plate Body: Resin Molding	SIS Compatible Detachable Bracket Available																
Front Derailleur FD-A300-B (Band Type) FD-A300-F (Italian Type)	Capacity: 14T. Band Diameter: $\phi 28.0\text{mm}$ — $\phi 28.6\text{mm}$. Stroke (w/ $\phi 28.6\text{mm}$ Band): 37 ~ 51 Narrow Type Chain Compatible 123g (Band Type)	Leading Action Pantograph Mechanism Rigid Chainguide Compact Design Cable Stopper	Front Band: Steel • Pearl Bright Finish Rear Band: Steel • Pearl Bright Finish Right Link: Steel • Zinc Plated : Resin • Molding Chainguide: Chrome Plated																	
Shifting Lever SL-A400-FCAI (Blazed-on A Type) SL-A400-BCAI (Side Band A Type)	7-speed SIS Down Tube Lever Lever Clamp Diameter: 28.6mm. 76g (SL-A250-FCAI)	SIS-Friction Mode Switch Light Action Lever Sealed Mechanism	Light Alloy • Barrel Finish	(C) means Italian Type Fixing Bolt is 5mm Diameter																
Caliper Brake BR-A250-49 (Short 49 Type) BR-A250-57 (Long 57 Type)	SLR (Shimano Linear Response) Compatible Sunken Bolt type Front: 27.5mm. Rear: 12.8mm. Nut Type Front: 47.0mm. Rear: 30.0mm. 313g (F & R, 49 Type)	Spring Sleeve Coated Pivot Washer One Piece & Low Profile Brake Shoes	C-Arm: Light Alloy • Barrel Finish Y-Arm: Light Alloy • Barrel Finish	For SLR System use with SLR compatible brake lever and Shimano outer cable with liner.																
Brake Lever BL-A251 (Aero Type)	SLR (Shimano Linear Response) Compatible Lever Clamp Diameter: 23.8mm. — 24.2mm. Lever Stroke: 88 310g (BL-A251, Pair)	With Quick Release Aerodynamic Design Extension Lever (Option)	Lever: Light Alloy • Barrel Finish Bracket: Steel • Zinc Plated Cover: Soft Resin • Molding Back: White	For SLR System use with SLR compatible brake and Shimano outer cable with liner																
Front Chainwheel FC-A400-BP (Biopace Double, LD Type) Bottom Bracket Assembly BB-A450 BB-UN10	Narrow Type Chain Compatible Crank Length: 165mm., 170mm. Teeth: Top 52T. Low 42T. Crank Thread: English BC 9/16" × 20T.P.I. Crank Thread: English BC 1.37 × 24T.P.I., French M35 × 1.0, Italian M36 × 24T.P.I. 920g (42T., 52T., 170mm.) 333g (BB. Set)	Sealed Mechanism (BB.)	Crank Arm: Light Alloy • Barrel Finish Chain Ring: Steel • Paint Finish	Spindle I <table border="1"> <thead> <tr> <th></th> <th>BB-A450</th> <th>BB-UN10</th> </tr> </thead> <tbody> <tr> <td>Mark</td> <td>5H</td> <td>3H</td> </tr> <tr> <td>Width</td> <td>70</td> <td>68</td> </tr> <tr> <td>Length</td> <td>115</td> <td>113</td> </tr> </tbody> </table>		BB-A450	BB-UN10	Mark	5H	3H	Width	70	68	Length	115	113				
	BB-A450	BB-UN10																		
Mark	5H	3H																		
Width	70	68																		
Length	115	113																		
Freehub FH-HG50	7-speed SIS Compatible UG/HG Compatible Type Spoke Holes: 36H., 32H. Hole PCD: 45 <table border="1"> <thead> <tr> <th>O.L.D.</th> <th>135</th> <th>130</th> <th>126</th> </tr> </thead> <tbody> <tr> <td>Axle Length</td> <td>146</td> <td>141</td> <td>137</td> </tr> <tr> <td>Mounting Type</td> <td>Quick Release</td> <td>Nut</td> <td></td> </tr> </tbody> </table> Axle Thread: 10mm. 435g (7-speed w/Quick Release)	O.L.D.	135	130	126	Axle Length	146	141	137	Mounting Type	Quick Release	Nut		Uni-Balance System Resin Sealed Mechanism (Choice) One-Piece Forged Hub Body	Light Alloy • Dia-Cut Finish					
O.L.D.	135	130	126																	
Axle Length	146	141	137																	
Mounting Type	Quick Release	Nut																		
Front Hub HB-RM50-F	Spoke Holes: 36H., 32H. Hole PCD: 38 <table border="1"> <thead> <tr> <th>O.L.D.</th> <th>100</th> <th>96</th> </tr> </thead> <tbody> <tr> <td>Axle Length</td> <td>108</td> <td>104</td> </tr> <tr> <td>Mounting Type</td> <td>Quick Release</td> <td></td> </tr> </tbody> </table> Axle Thread: 9mm 228g	O.L.D.	100	96	Axle Length	108	104	Mounting Type	Quick Release		Resin Sealed Mechanism (Choice) One-Piece Forged Hub Body	Light Alloy • Dia-Cut Finish								
O.L.D.	100	96																		
Axle Length	108	104																		
Mounting Type	Quick Release																			
Cassette Sprockets CS-HG50 (7-Speed)	7-speed SIS Compatible 7-speed HG Use Narrow Type Chain 268g. (Sprocket I Group)		Steel • Brown Finish & Silver Finish (Low Gear)	Cassette Sprocket Combinations: J 13, 14, 15, 16, 17, 19, 21T. I 13, 14, 15, 17, 19, 21, 23T. H 13, 15, 17, 19, 21, 23, 26T. M 13, 15, 17, 19, 21, 24, 28T. L 12, 13, 14, 15, 17, 19, 21T. E 12, 14, 16, 18, 21, 24, 28T.																
Chain CN-HG50	7-speed SIS Compatible 7-speed HG Compatible Narrow Type Chain (1/2" × 3/32") 335g. (114 Link)	Chrome finish Link Pin Connecting Pin Bushings Design	Roller Link Plate: Steel • Black Finish Pin Link Plate: Steel • Black Finish																	
Pedal PD-A550	Crank Thread: English BC 9/16" × 20T.P.I. Toe Clip Size: M, L, LL Top Clip Locking System: 3-screw 407g. (Pair, Including Toe Clip Size L)	32° 30" Road Clearance Easy-Maintenance Cartridge Axle Sealed Mechanism Aerodynamic Design Reflector (Option)	Plate & Body: Light Alloy • Barrel Finish Toe Clip: Resin																	
Head Parts HP-R500	Height: Upper Cone 22.0mm. Lower Cone 11.5mm. 121g. Valiation: <table border="1"> <thead> <tr> <th colspan="2"></th> <th colspan="2">Press Race Diameter</th> </tr> <tr> <th colspan="2"></th> <th>Upper Cone & Lower Cup</th> <th>Lower Cone</th> </tr> </thead> <tbody> <tr> <td>English/Italian</td> <td>BC1 × 24T</td> <td>30.2mm.</td> <td>26.4mm.</td> </tr> <tr> <td>French</td> <td>M25 × P1.0</td> <td>30.2mm.</td> <td>26.4mm.</td> </tr> </tbody> </table>			Press Race Diameter				Upper Cone & Lower Cup	Lower Cone	English/Italian	BC1 × 24T	30.2mm.	26.4mm.	French	M25 × P1.0	30.2mm.	26.4mm.	Sealed Mechanism	Lock Nut: Steel • Pearl Bright Finish Upper Cup: Resin Lower Cup: Resin Color: White, Silver, Black	
		Press Race Diameter																		
		Upper Cone & Lower Cup	Lower Cone																	
English/Italian	BC1 × 24T	30.2mm.	26.4mm.																	
French	M25 × P1.0	30.2mm.	26.4mm.																	

NEXUS

Expede 300EX

Model	Expede 300EX	Year	2003
Manufacturer	Shimano	Country of Origin	Japan
Material	Aluminum, Steel, Plastic	Weight	~1.5 kg
Capacity	7-Speed	Max. Load	~100 kg
Dimensions	~150 x 100 x 100 mm	Color	Silver/White

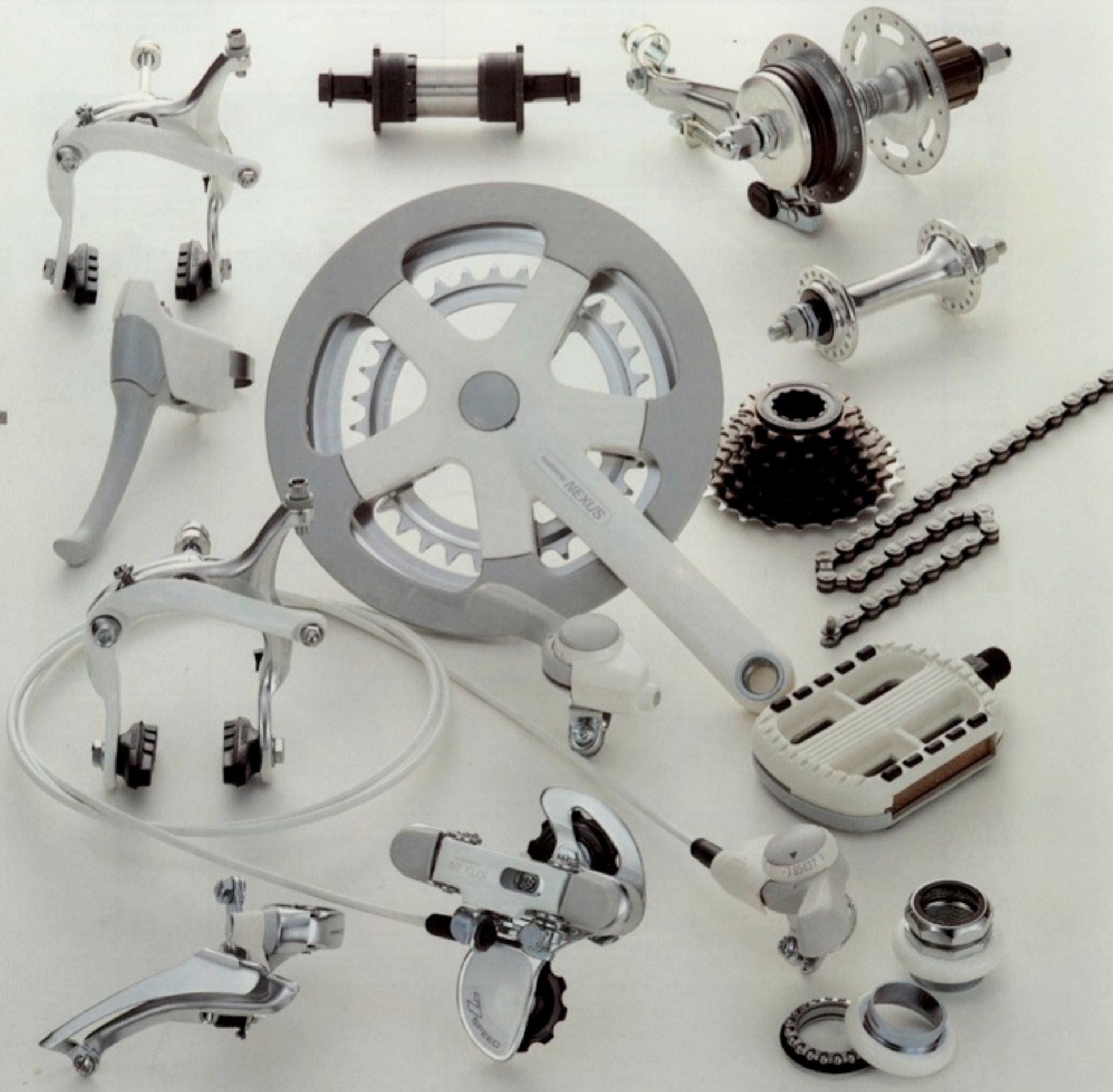

45
Nexus

Model No.	Specifications	Features	Material • Finish	Note
Rear Derailleur RD-E700	6 & 7-speed PPS Compatible Max. Rear Sprocket: 24-28T. (For Double) : 24-32T. (For Single) Min. Rear Sprocket: 12T. Front Difference: 12T. Total Capacity: 28T. 260g.	Cable Saver Arm Double Servo-Panta Mechanism Double Spoke Barrier Sintered Alloy Guide Pulley Bushing	Bracket Body: Light Alloy • Paint Finish Right Link: Steel • Paint Finish Left Link: Steel • Zinc Plated Plate Body: Light Alloy • Paint Finish	SIS Compatible Detachable Bracket Available
Rear Derailleur RD-E500-7	7-speed PPS Compatible Max. Rear Sprocket: 24-28T. (For Double) : 24-32T. (For Single) Min. Rear Sprocket: 12T. Front Difference: 12T. Total Capacity: 28T. 293g.	Cable Saver Arm Servo-Panta Mechanism Centeron Guide Pulley Double Spoke Barrier Sintered Alloy Guide Pulley Bushing	Bracket Body: Steel • Pearl Bright Finish Right Link: Steel • Pearl Bright Finish Left Link: Steel • Zinc Plated Plate Body: Steel • Pearl Bright Finish	Bracket Rivet Type Available
Front Derailleur FD-E700-B (Band Type) FD-E700-F (Italian Type)	Narrow Type Chain Compatible Capacity: 14T. Band Diameter: ϕ 28.0mm. — ϕ 28.6mm. Stroke (w/ ϕ 28.6mm. Band): 37 – 51 128g. (Band Type)	Leading Action Pantagraph Mechanism Rigid Chainguide Compact Design With Cable Stopper	Front Band: Steel • Pearl Bright Finish Rear Band: Steel • Pearl Bright Finish Right Link: Steel & Resin • Zinc Plated Chainguide: Pearl Bright Finish	
Shifting Lever SL-E700-7 (7-Speed)	7-speed PPS Handle Bar Use Brake Lever Unit Type 190g.	Light Action Lever Easy Assemble Lever Position & Reach Adjust Brake Lever Integrated Angle Adjust	Bracket: Light Alloy • Barrel Finish Lever: Resin • Molding	Use with Shimano PPS Cable with Liner (Rear).
Shifting Lever SL-E500-7 (7-Speed)	7-speed PPS Handle Bar Use Lever Clamp Diameter: 22.2-23.5mm. 60g. (Left), 158g. (Right w/Outer Cable)	Easy Assemble	Bracket: Steel • Chrome Plated Lever: Resin • Molding	Use with Shimano PPS Cable with Liner (Rear).
Dual Pivot Brake BR-E700 BR-E700-L (For Lady) BR-R500 BR-R500-L (For Lady)	Super-SLR (Shimano Linear Response) Compatible Sunken Bolt type: Front: 27.5mm. Rear: 12.8mm. Nut Type: Front: 47.0mm., 56.0mm. Rear: 30.0mm., 35.0mm. 193g. (F & R)	Easy Adjust With Synchronizer Spring Sleeve Coated Pivot Washer One Piece & Low Profile Brake Shoe	BR-E700 C-Arm: Light Alloy • Paint Finish Y-Arm: Light Alloy • Paint Finish Gate: Light Alloy • Barrel Finish BR-R500 C-Arm: Light Alloy • Barrel Finish Y-Arm: Light Alloy • Barrel Finish Gate: Light Alloy • Barrel Finish	BR-E700, BR-R500 must be used as a set with BL-E700, BL-R500 and the Shimano SLR outer cable. No other combination can be used.
Brake Lever (4-Finger) BL-E700-EM (Unit Type) BL-E700-NL (Separate Type) BL-R500	Super-SLR (Shimano Linear Response) Compatible Lever Clamp Diameter: 22.2mm. — 23.8mm. Lever Stroke: 84 275g. (BL-E700, Pair)	Lever Stroke Adjustable	Lever: Steel • Resin Coated & Resin Bracket: Steel • Resin Coated & Resin Color: White & Gray, Black & Gray	BL-E700, BL-R500 must be used as a set with BR-E700, BR-R500 and the Shimano SLR outer cable. No other combination can be used.
Front Chainwheel FC-E700-W (Double, Special Pitch) FC-E700-S (Single, Special Pitch) FC-R500-W (Double, Rivet Type) FC-R500-S (Single, Rivet Type) Bottom Bracket Assembly BB-UN10	Narrow Type Chain Compatible Crank Length: 165mm., 170mm. Teeth: 44T., 32T. (Double) 44T. (Single) Crank Thread: English BC 9/16" × 20T.P.I. Crank Thread: English BC 1.37 × 24T.P.I., French M35 × 1.0, Italian M36 × 24T.P.I. Chain Line: 43.5mm. 790g. (FC-E700-W) 333g. (BB. Set)	Flat Surface Chainguard Sealed Mechanism (B.B.)	FC-E700 Crank Arm: Light Alloy • Paint Finish Chain Ring: Light Alloy • Anodized Finish FC-R500 Crank Arm: Steel • Zinc Plated Resin • Molding Chain Ring: Steel • Pearl Bright Finish	Spindle: Mark D-H Length 115
Freehub FH-R700 FH-R500	6 & 7-speed PPS Compatible UGHG Compatible Type Spoke Holes: 36H., 32H. Hole PCD: 45 O.L.D. 126 Axle Length 174 Axle Thread: 3/8" × 1.045g. (FH-R700)	Uni-Balance System Resin Sealed Mechanism	FH-R700 Light Alloy • Polish Finish FH-R500 Steel • Polish Finish	Usable Dropout Thickness: Right: 4 – 9mm. Left: 4 – 8mm.
Front Hub HB-RM50-F	Spoke Holes: 36H., 32H. Hole PCD: 38 O.L.D. 100 96 Axle Length 108 104 Mounting Type Quick Release Axle Thread: 9mm 228g.	Sealed Mechanism (Choice) One-Piece Design	Light Alloy • Dia-Cut Finish	
Pedal PD-M400	Crank Thread English BC 9/16" × 24T.P.I. Standard Type 374g. (Pair)	Sealed Mechanism Reflector	Body: Resin	
Cassette Sprockets CS-HG50 (7-Speed) Chain CN-HG50 Head Parts HP-R500	See Page 42			

Shimano Total Integration Realizes Upgraded Control and a More Enjoyable Mountain Bike Experience.

Shimano Total Integration is now standard equipment on all Shimano off-road component groups. This means that Shimano off-road riders can now can steer, shift gears, and brake without ever removing their hands from the handlebars. Now everybody, from off-road racers to casual "fat tire" riders can realize the improved performance, safety, and enjoyment that totally integrated control makes possible.

There's a Shimano off-road group for virtually any off-road riding style. The competition-oriented Deore-XT group continues to be the benchmark to which all off-road components are compared. Deore LX delivers high-performance functions to entry level off-road bicycles. The 200GS series provides a safe and easy-control cycling experience for casual cyclists and young riders.

They all have one thing in common—advanced human engineered design that makes cycling safer, more efficient, and more enjoyable than ever before.



SLR

SIS

**SHIMANO
SG**

**THE SHIMANO
FREEHUB**

HG

biopace

Component Group	Theme & Application	Main Features	User Benefits	New for 1991
SHIMANO DEORE XT	The best performing and highest quality off-road component group for competitive level mountain bicycle.	Features the quality, durability, and control response demanded by competitive-level off-road cyclists.	Provides off-road racers with a real competitive advantage.	<ul style="list-style-type: none"> • SPD pedal (PD-M737) features cleat binding mechanism on both sides. • Improved SLR Plus brake lever (ST-M092) features cam action which modulates the mechanical advantage. • Low profile cantilever brakes (BR-M734) protrude less and are easier to install and adjust. • New stronger chain (CN-HG91) developed for use with HG gears in order to provide greater strength and durability.
SHIMANO DEORE DX	A quality high-performance off-road group for the performance oriented mountain bike.	Features high performance functions like "one-touch" shifting across the entire gear range.	Provides off-road riding enthusiasts with a highly efficient level of control and performance.	<ul style="list-style-type: none"> • Low profile cantilever brake (BR-M650) features narrow design and is easier to install and adjust.
SHIMANO DEORE LX	A quality component group for the entry-level mountain bike.	Features greater strength and durability than the Exage components.	Provides the novice or casual off-road rider with much the same performance of Deore-XT or DX but at a lower price.	<ul style="list-style-type: none"> • Three-finger Rapidfire shift lever (ST-M060) is easily operated with the hand in the normal bar-gripping position.
EXAGE 500LX EXAGE 400LX EXAGE 300LX	An economical off-road type component group for cruiser and general use fat tire bicycles.	Features advanced component functions for easy and safe riding.	Provides casual cyclists with a cruiser type bike that's safe, easy, and fun to ride.	<ul style="list-style-type: none"> • Three-finger Rapidfire shift lever (ST-M050) is easily operated with the hand in the normal bar-gripping position. • Rear cantilever brake (BR-M352) is designed specifically for small frames to prevent foot contact.
SHIMANO 200GS SHIMANO 100GS	General purpose components made in the mountain bike style for fat tire utility bikes and young peoples' bicycles.	Features advanced functions and durable design that make a great cost-performance value.	Provides people with general purpose bicycles that are easier and more enjoyable to ride than ever before.	<ul style="list-style-type: none"> • Brake lever (BL-M201) designed for easy operation and optimum compatibility with shifting lever (ST-M020). • Low profile cantilever brake features easier operation and narrow design. • The new components 100GS series (Europe only)

Off-road Component Group Positioning

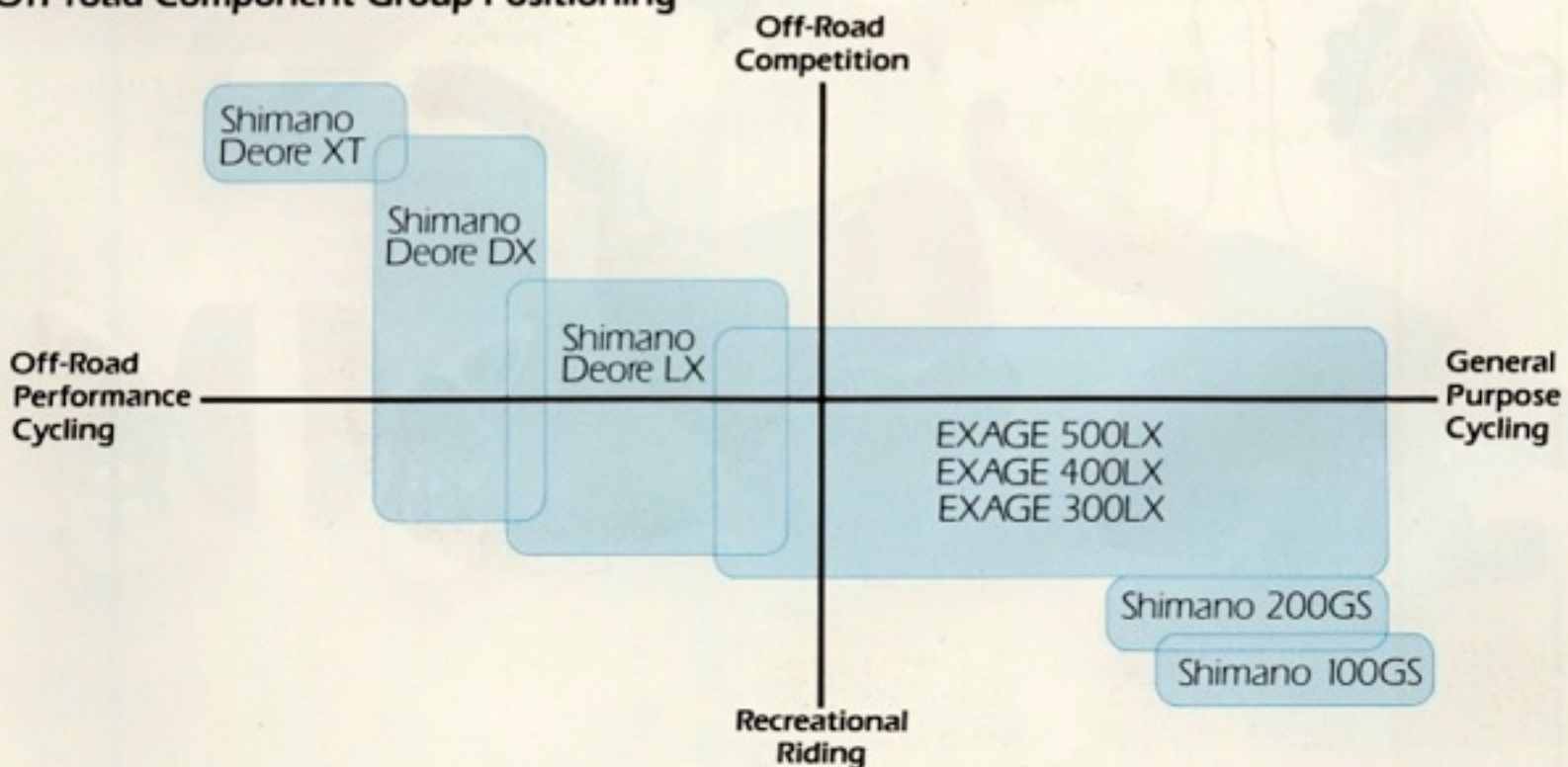

SHIMANO DEORE XT

SHIMANO
TOTAL
INTEGRATION



Deore XT was developed to be Shimano's finest off-road component group. Aimed at off-road racers and the most demanding off-road enthusiasts, Deore XT offers the highest level of quality and function found in any off-road group today. Rugged construction, top quality materials, and high mechanical precision assure that Deore XT will stand up to the punishment of all-out racing. Shimano Total Integration further enhances Deore XT with a refined feeling of "hands-on" control that's a great competitive advantage.



SHIMANO DEORE XT



Rear Derailleur

RD-M735-SGS (Super Long Cage)
RD-M735-SS (Short Cage)

Weight	270g. (Super Long Cage), 250g. (Short Cage)
Compatibility	Shimano Total Integration Compatible, 6, 7-speed SIS Compatible
Features	Adjustable Return Spring, Sealed Link Pivots, Sealed Pulley, Sealed Pivot & Bracket Axles (O-Rings), Double Servo-Panta Mechanism, B-Tension Adjust Bolt, Double Spoke Barrier, Chain Retainer (Super Long Cage)
Capacity	Maximum Rear Sprocket: 32T. (Super Long Cage), 28T. (Short Cage) Minimum Rear Sprocket: 12T. Front Difference: 20T. (Super Long Cage), Total Capacity: 38T. (Super Long Cage), 28T. (Short Cage)
Material & Finish	Light Alloy•Buff Finish (Bracket & Pulley Body), Light Alloy•Anodized Finish (Right Link), Light Alloy•Barrel Finish (Left Link)

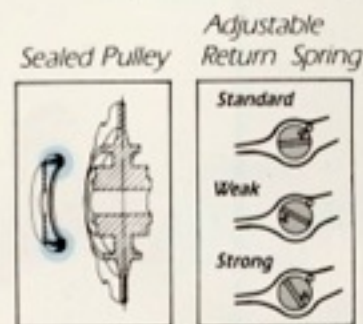
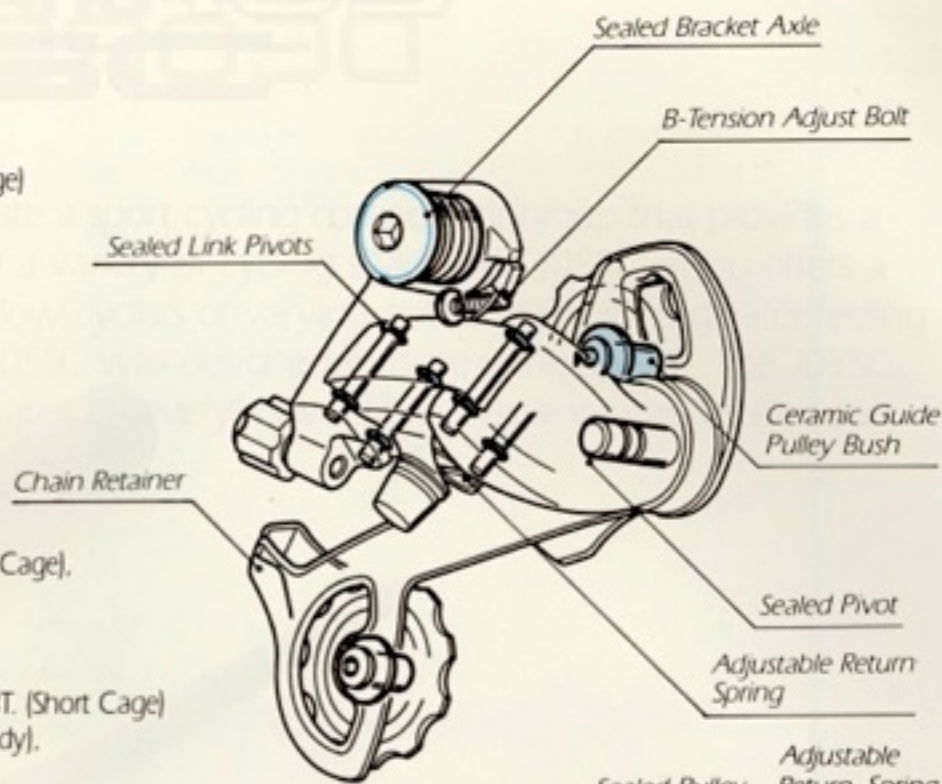

Front Derailleur
FD-M735

Weight	116g. (Normal Band Type)
Compatibility	Shimano Total Integration Compatible, Shimano SG Gear Compatible
Features	Trailing Action Pantagraph Mechanism, Pull-Top Type Available, Narrow Type Chain Compatible, Adjustable Return Spring, Rigid Chain Guide, New Trapease Mechanism, Sealed Link Pin
Capacity	24T. (Biopace HP), 26T. (Round)
Clamp Diameter	Ø28.0mm.—28.6mm., 30.0mm., 31.8mm., 34.9mm.
Material & Finish	Light Alloy•Buff Finish (Front & Rear Band), Light Alloy•Anodized Finish (Right Link), Steel•Chrome-Plated (Chain Guide)

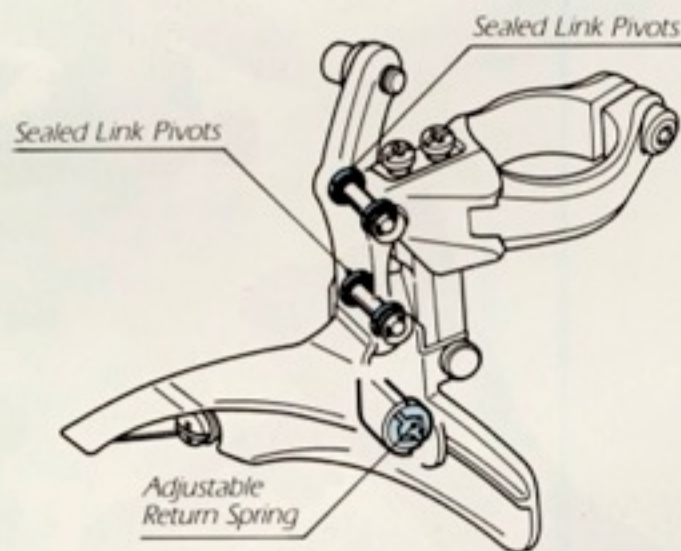

Rapidfire

ST-M092 (Servo-Wave, 2-Finger)
ST-M091 (2-Finger)
ST-M090 (4-Finger)

Weight	550g. (ST-M091)
Compatibility	Shimano Total Integration Compatible, SLR (Shimano Linear Response) PLUS Compatible (ST-M092), 7-speed SIS Compatible
Features	Dual Repeat Function, Brake Lever Stroke Adjust, Shifting Lever Angle Adjust, Light Action Lever
Lever Clamp Diameter	22.2mm.
Material & Finish	Light Alloy•Anodized Finish (Bracket & Lever), SLR outer casing with liner (Brake Lever) and SIS-SP Sealed outer casing with liner (Shifting Lever)
Use	

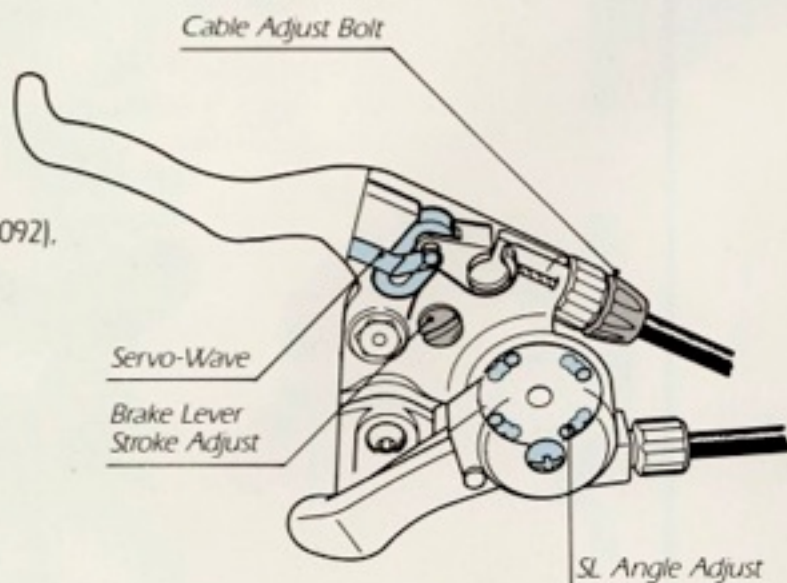

Shifting Lever
SL-M732

- Weight** 182g.
Features 7-speed SIS,
 SIS-Friction Mode Switch,
 Light Action Lever,
 Low Profile Design,
 3-Step Lever Adjust,
 Digital Cable Adjust
Lever Clamp Diameter 22.2mm.
Material & Finish Light Alloy•Anodized Finish (Bracket),
 Light Alloy•Buff Finish (Lever)
Attachment Position Handlebar



Cantilever Brake
BR-M734

- Weight** 172g. (Pair)
Compatibility Shimano Total Integration Compatible,
 SLR (Shimano Linear Response) PLUS Compatible
Features Super Low Profile Design,
 Easy Cable Attachment,
 Spring Tension Adjuster,
 Easy Shoe Adjust,
 Internal Spring Design
Material & Finish Light Alloy•Buff Finish
Use BR-M734 must be used as a set with ST-M092 and the
 Shimano SLR outer cable. No other combination can be used.

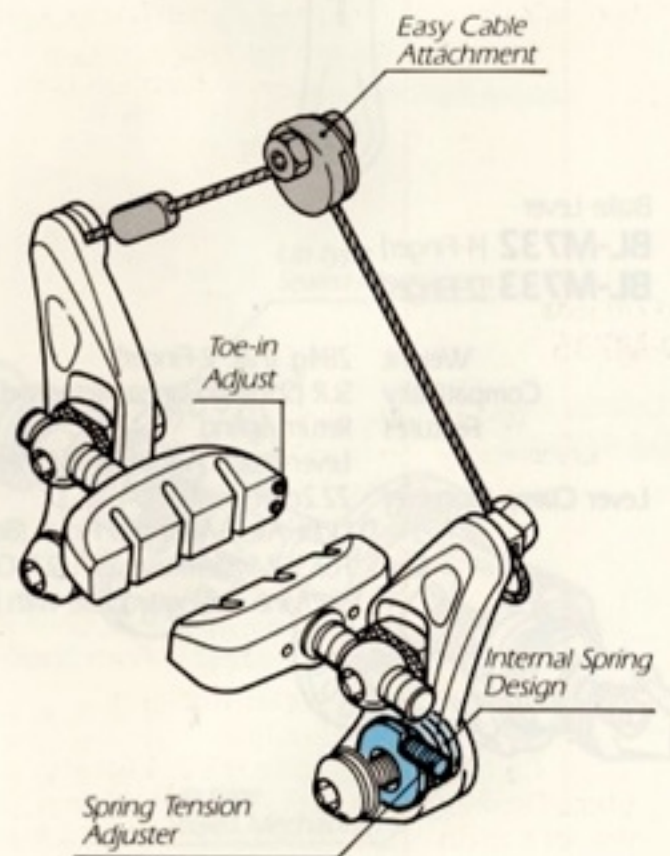

Cantilever Brake
BR-M732

- Weight** 185g. (Pair)
Compatibility Shimano Total Integration Compatible,
 SLR (Shimano Linear Response) Compatible
Features Spring Tension Adjuster,
 Easy Cable Attachment
Material & Finish Light Alloy•Buff Finish (Black Finish Available)
Use For SLR System use with SLR Compatible brake lever and
 Shimano SLR outer cable with liner.

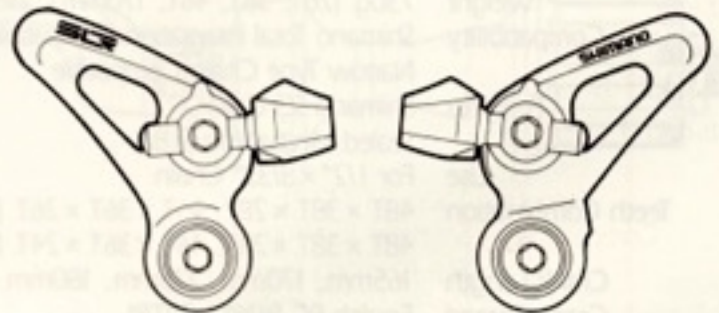

U-II Brake
BR-M733

- Weight 375g. (1 Unit)
- Compatibility Shimano Total Integration Compatible, SLR (Shimano Linear Response) Compatible
- Feature Power Plate with Shark Tooth
- Material & Finish Light Alloy•Anodized Finish
- Use For SLR System use with SLR Compatible brake lever and Shimano SLR outer cable with liner.

Power Plate with Shark Tooth

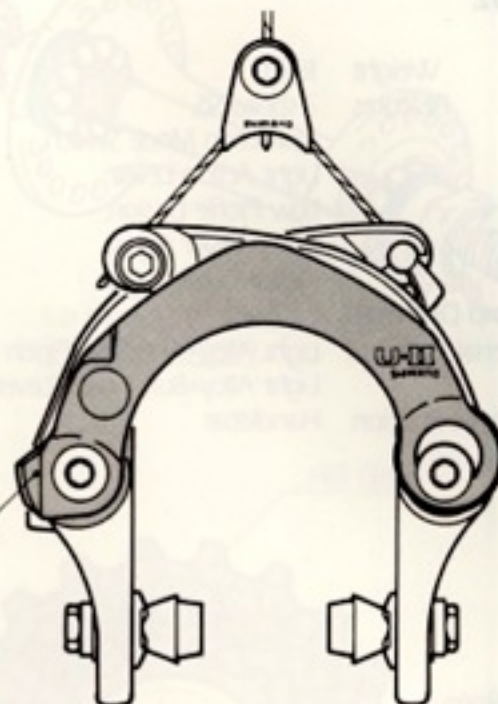

Brake Lever
BL-M732 (4-Finger)
BL-M733 (2-Finger)

- Weight 284g. (Pair, 2-Finger)
- Compatibility SLR (Shimano Linear Response) Compatible
- Features Return Spring, Lever-Reach Adjustment (4-Positions)
- Lever Clamp Diameter 22.2mm.
- Material & Finish Light Alloy•Anodized Finish (Bracket & Lever)
- Use For SLR System use with SLR Compatible Brake and Shimano SLR outer cable with liner.

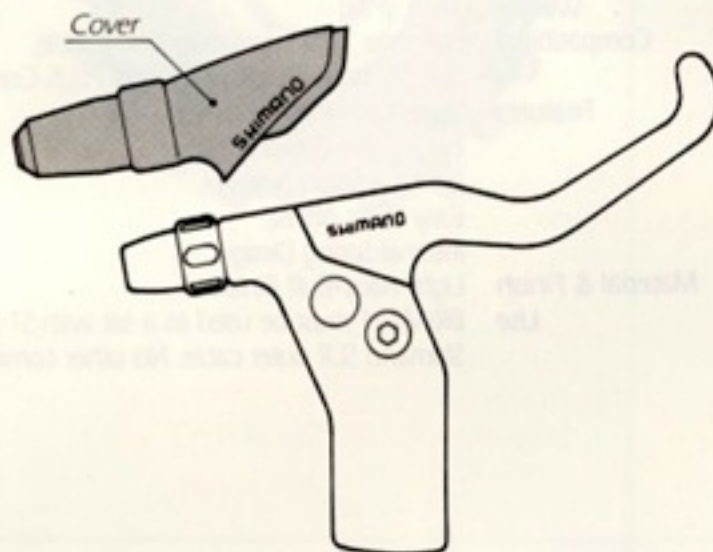

Front Chainwheel & Bottom Bracket Assembly
FC-M730-SG (Shimano SG Triple, MD Type)
BB-M730 (B.B. Set)

- Weight 730g. (26T., 36T., 46T., 170mm.), 295g. (B.B. Set)
- Compatibility Shimano Total Integration Compatible, Narrow Type Chain Compatible
- Features Shimano SG Gear, Sealed Mechanism (B.B.)
- Use For 1/2" x 3/32" Chain
- Teeth Combination 48T. x 38T. x 28T., 46T. x 36T. x 26T. (Biopace SG), 48T. x 38T. x 28T., 46T. x 36T. x 24T. (Round SG)
- Crank Length 165mm., 170mm., 175mm., 180mm.
- Crank Thread English BC 9/16" x 20T.P.I.
- Cup Thread English BC 1.37 x 24T.P.I., French M35 x 1.0, Italian M36 x 24T.P.I.
- B.B. Size 70-T-122.5, 68-T-122.5, 73-T-121.5, 68-T-127.5
- Material & Finish Light Alloy•Anodized Finish (Crank, Chaining)

Shimano SG Gear



Freehub

FH-M732 (Rear, 7-speed)

Weight	490g. (with Quick Release)
Compatibility	Shimano Total Integration Compatible, 7-speed SIS Compatible
Features	Lip Type Sealed Mechanism, HG/UG Convertible Type, Uni-Balance System.
Over Lock Nut Dimensions	136mm., 130mm. (Quick Release Type), 135mm., 130mm. (Nut Type)
Axle Length	146mm., 141mm. (Quick Release Type), 185mm., 180mm. (Nut Type)
Axle Thread	M10
Spoke Holes	32H, 36H
Hole PCD	45
Material & Finish	Light Alloy•Buff Finish (Hub Shell)

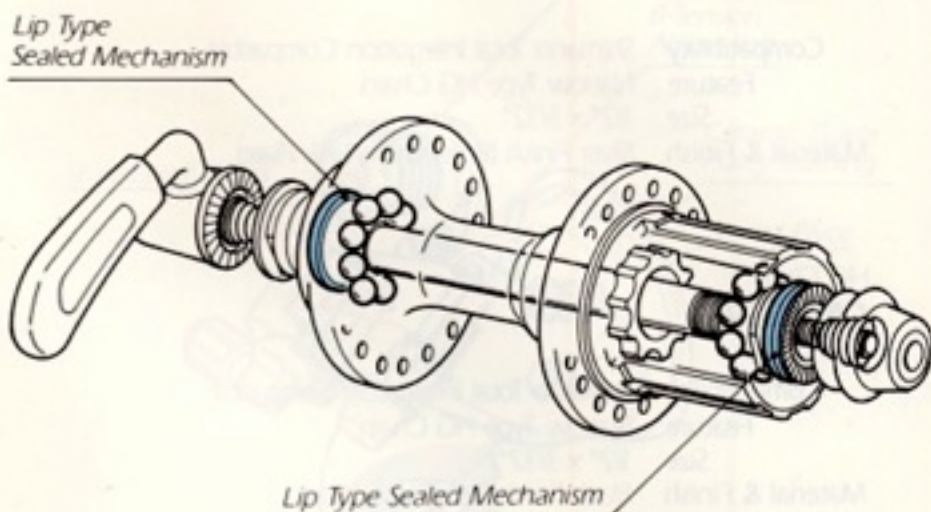

Front Hub

HB-M730-F

Weight	213g. (with Quick Release)
Feature	Lip Type Sealed Mechanism
Over Lock Nut Dimensions	100mm.
Axle Length	108mm. (Quick Release Type), 142mm. (Nut Type)
Axle Thread	M9
Spoke Holes	32H, 36H
Hole PCD	38
Material & Finish	Light Alloy•Buff Finish (Hub Shell)

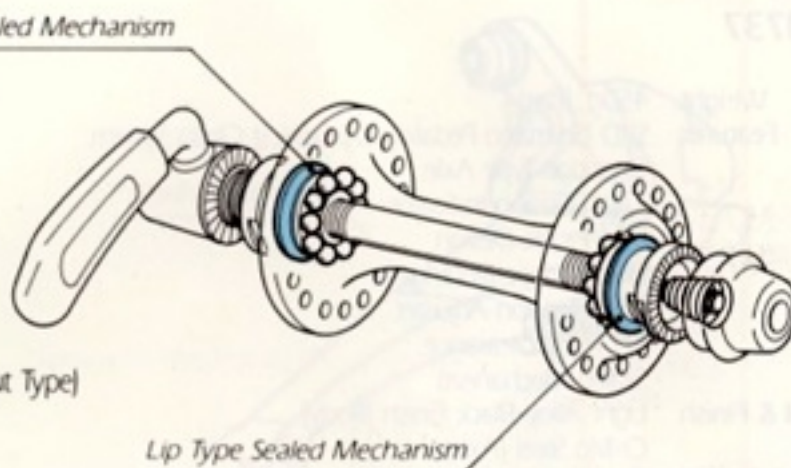

Cassette Sprockets

CS-HG90 (7-speed)

Weight	325g. (Sprocket I Group & Spacer)
Compatibility	7-speed SIS Compatible
Feature	7-speed HG
Use	For 1/2" x 3/32" Chain (Narrow Type Chain)
Material & Finish	Steel•Chrome Plated
Sprocket Combinations	

- E** 12, 14, 16, 18, 21, 24, 28T.
- F** 14, 16, 18, 21, 24, 28, 32T.
- G** 13, 15, 17, 20, 23, 26, 30T.
- H** 13, 15, 17, 19, 21, 23, 26T.
- I** 13, 14, 15, 17, 19, 21, 23T.
- J** 13, 14, 15, 16, 17, 19, 21T.
- K** 13, 15, 17, 20, 24, 29, 34T.
- L** 12, 13, 14, 15, 17, 19, 21T.
- M** 13, 15, 17, 19, 21, 24, 28T.

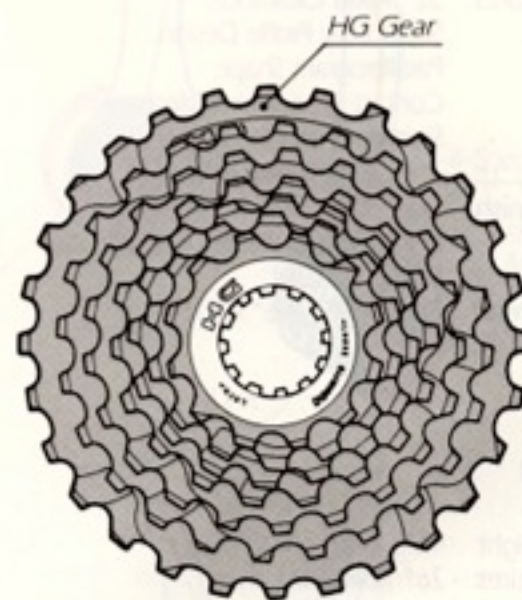

HG Chain
CN-HG91

Compatibility Shimano Total Integration Compatible
 Feature Narrow Type HG Chain
 Size 1/2" x 3/32"
 Material & Finish Silver Finish (Roller & Pin Link Plate)



HG Chain
CN-HG90

Compatibility Shimano Total Integration Compatible
 Feature Narrow Type HG Chain
 Size 1/2" x 3/32"
 Material & Finish Black Finish (Roller Link Plate),
 Silver Finish (Pin Link Plate)

SPD Pedal
PD-M737

Weight 450g. (Pair)
 Features SPD (Shimano Pedaling Dynamics) Cleats System,
 Cartridge Type Axle,
 Cleat Tension Indicator,
 Low-Profile Design,
 Dual Surface Binding,
 Cleat Tension Adjuster,
 31° Road Clearance,
 Sealed Mechanism
 Material & Finish Light Alloy•Black Finish (Body),
 Cr-Mo Steel (Axle)
 Crank Thread English BC 9/16" x 20T.P.I.

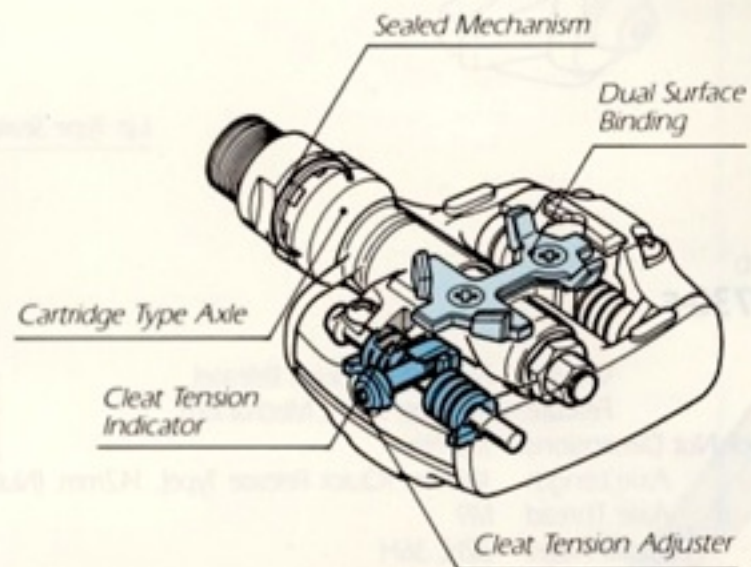

Pedal
PD-M735

Weight 295g. (Pair)
 Features 32° Road Clearance,
 Super Low Profile Design,
 Parallelogram Shape,
 Contact Type Sealed Mechanism,
 Stainless Steel Grip Pin,
 Toe Clip/Reflector Attachable
 Material & Finish Light Alloy (Body),
 Light Alloy•Anodized Finish (Plate),
 Resin (Toe Clip)
 Crank Thread English BC 9/16" x 20T.P.I.

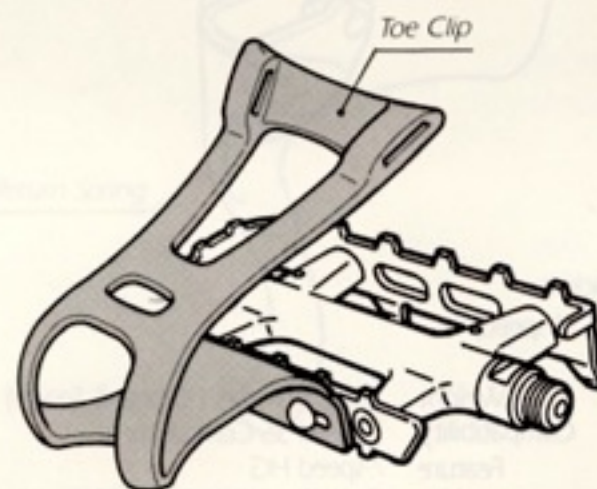

Pedal
PD-M730

Weight 412g. (Pair)
 Features 26° Road Clearance,
 Low Profile Design,
 Parallelogram Shape,
 Contact Type Sealed Mechanism,
 Stainless Steel Grip Pin,
 Toe Clip/Reflector Attachable
 Material & Finish Light Alloy (Body),
 Light Alloy•Anodized Finish (Plate)
 Crank Thread English BC 9/16" x 20T.P.I.

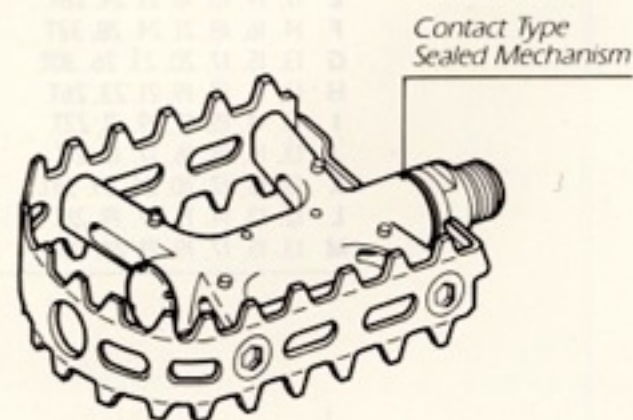

Seat Pillar
SP-M730

Weight 296g. (330mm.)
 Features High Strength Structure,
 Light Weight,
 Long Size
 Outside Diameter 26.6mm., 26.8mm., 27.0mm.
 Length 280mm., 330mm.
 Material Cr-Mo Steel

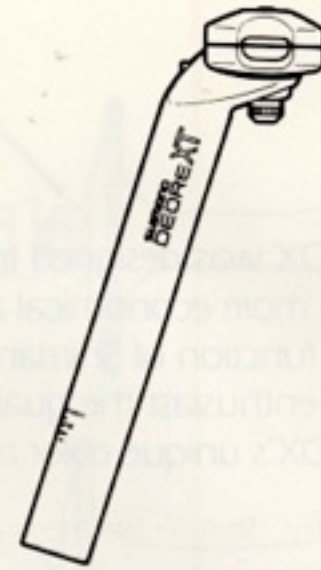

Seat Pillar Quick Release
SQ-M730

Weight 75g.
 Features Easy Operation,
 Position Set Spring
 Shaft Adjustment Length 36—43mm., 26—33mm.
 Shaft Diameter \varnothing 6mm., \varnothing 8mm.
 Material & Finish Steel•Chrome-Plated Finish

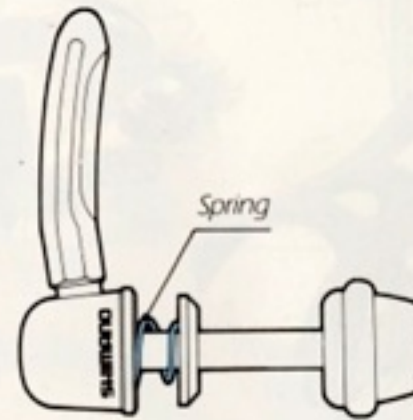

Chain Deflector
DF-M730

Weight 9g.
 Feature Keeps the Chain from jamming between the Tire & Chainstay
 Material Resin

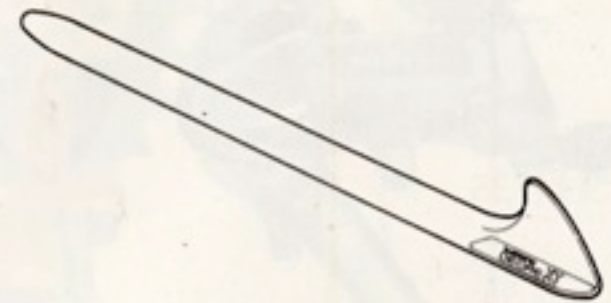

Head Parts
HP-M735
HP-M736
HP-M737

Weight 110g. (HP-M735), 149g. (HP-M736), 155g. (HP-M737)
 Type Off-Road Type
 Feature Sealed Mechanism
 Material & Finish Light Alloy•Anodized Finish (Nut),
 Steel (Upper Cup),
 Stainless Steel •Black Finish (Lower Cup)

Variation & Dimensions:

Type	HP-M735		HP-M736	HP-M737
Thread	BC1" x 24T.	M25 x P1.0	BC1-1/8" x 26T.	BC1-1/4" x 26T.
A	30.2mm.	30.2mm.	34.0mm.	37.0mm.
B	26.4mm.	26.4mm.	30.0mm.	33.0mm.
C	22.1mm.		25.5mm.	28.7mm.
D	32.0mm.		36.0mm.	40.0mm.
t_1	22.0mm.		22.0mm.	27.3mm.
t_2	11.5mm.		11.5mm.	13.0mm.

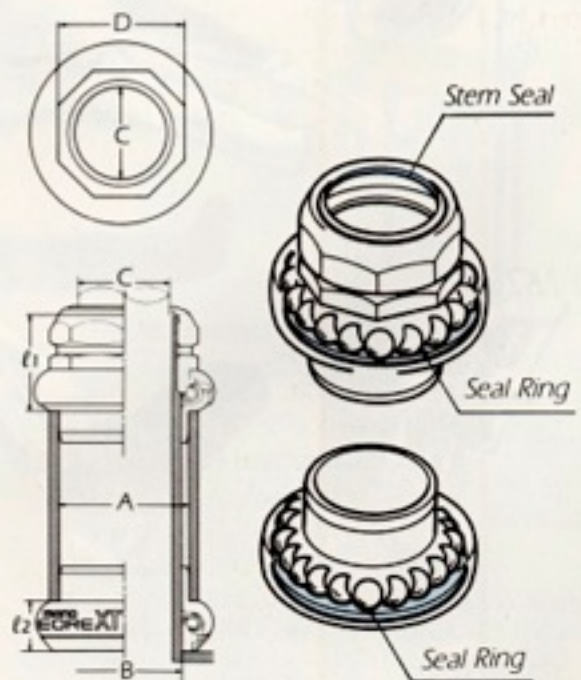

SHIMANO DEORE DX

SHIMANO
TOTAL
INTEGRATION



Deore DX was designed to give off-road cycling enthusiasts all the advanced functions of Deore XT in a more economical and slightly heavier component group. In addition to the "hands-on" control function of Shimano Total Integration, the Deore DX-equipped bicycle offers the off-road cycling enthusiast the quality and performance that satisfy every need short of all-out competition. Deore DX's unique color treatment adds a distinctive look of quality and style to any mountain bike.



Rear Derailleur

RD-M650-SGS (Super Long Cage)

RD-M650-SS (Short Cage)

- Weight** 320g. (Super Long Cage), 257g. (Short Cage)
- Compatibility** Shimano Total Integration Compatible,
6 & 7-speed SIS Compatible
- Features** Sealed Link Pivots,
Sintered Alloy Guide Pulley,
Centeron Guide Pulley,
Sealed Tension Pulley,
Sealed Pivot & Bracket Axles (O-Rings),
Double Servo-Panta Mechanism,
B-Tension Adjust Bolt,
Double Spoke Barrier,
Chain Retainer (Super Long Cage)
- Capacity** Maximum Rear Sprocket: 32T. (Super Long Cage),
28T. (Short Cage)
Minimum Rear Sprocket: 12T.
Front Difference: 20T. (Super Long Cage),
Total Capacity: 38T. (Super Long Cage), 28T. (Short Cage)
- Material & Finish** Light Alloy•Barrel Finish (Bracket & Plate Body)
Light Alloy•Paint Finish (Right Link)
Steel•Pearl Bright Finish (Left Link)

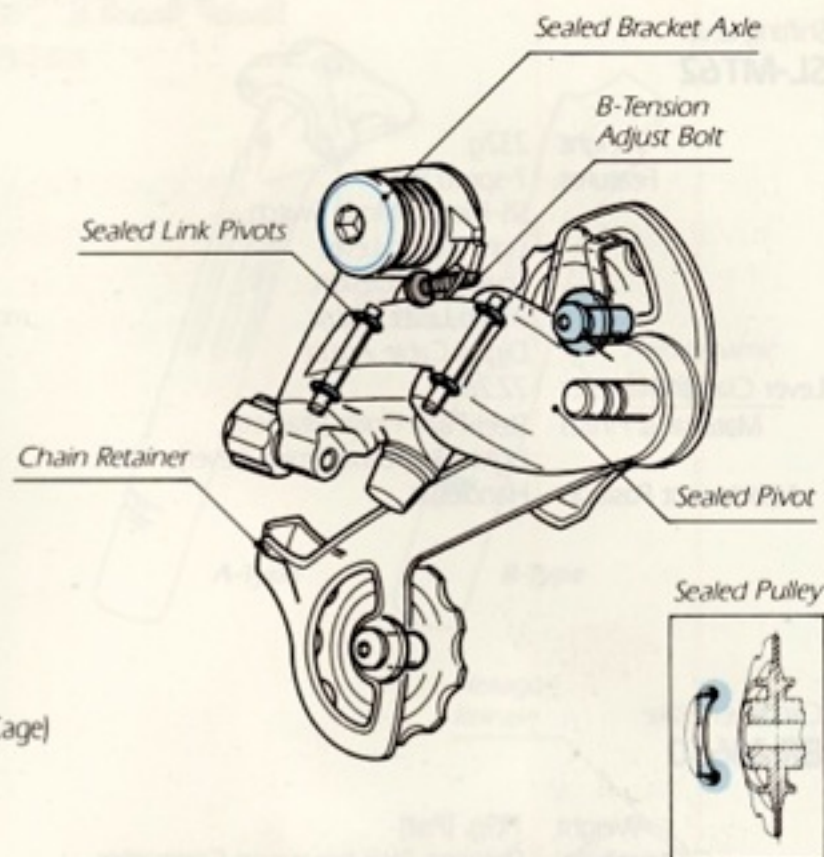

Front Derailleur

FD-M650

- Weight** 117g. (Normal Band Type)
- Compatibility** Shimano Total Integration Compatible,
Shimano SG Gear Compatible,
Narrow Type Chain Compatible
- Features** Trailing Action Pantagraph Mechanism,
Pull-Top Type Available,
Sealed Mechanism,
Rigid Chain Guide,
New Trapease Mechanism
- Capacity** 24T. (Biopace HP), 26T. (Round)
- Clamp Diameter** \varnothing 28.0mm—28.6mm, 30.0mm, 31.8mm, 34.9mm.
- Material & Finish** Light Alloy•Barrel Finish (Front & Rear Band),
Light Alloy•Paint Finish (Right Link),
Steel•Chrome-Plated (Chain Guide)

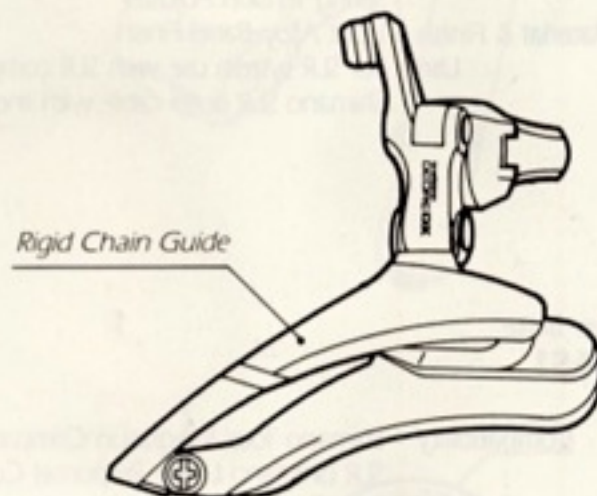

Rapidfire

ST-M071 (2-Finger)

ST-M070 (4-Finger)

- Weight** 535g. (ST-M071)
- Compatibility** Shimano Total Integration Compatible,
SLR (Shimano Linear Response) Compatible,
7-speed SIS Compatible
- Features** Dual Repeat Function,
Brake Lever Stroke Adjust,
Shifting Lever Angle Adjust,
Light Action Lever
- Lever Clamp Diameter** 22.2mm.
- Material & Finish** Light Alloy•Anodized Finish (Bracket),
Light Alloy•Paint Finish (Lever)
- Use** SLR Sealed outer casing with Liner (Brake Lever) and
SIS-SP Sealed outer casing with Liner (Shifting Lever)

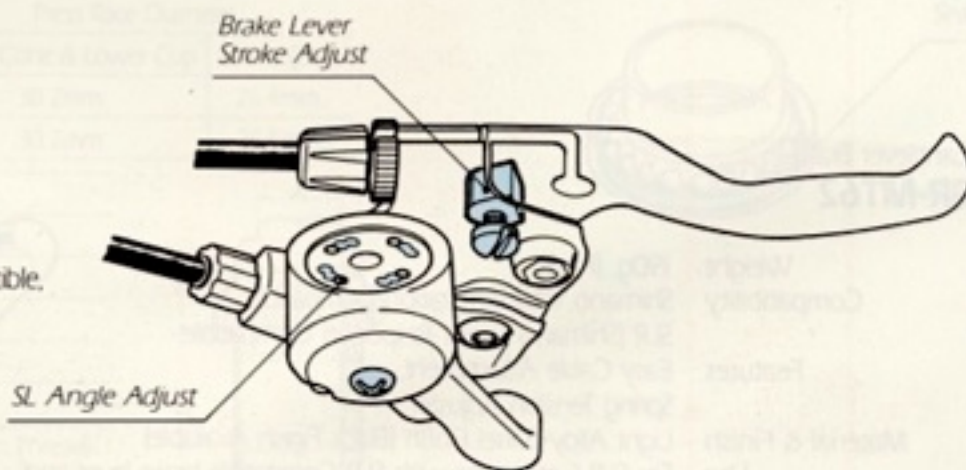

Shifting Lever
SL-MT62

- Weight** 232g
- Features** 7-speed SIS, SIS-Friction Mode Switch, Light Action Lever, Low Profile Design, 3-Step Lever Adjust, Digital Cable Adjust
- Lever Clamp Diameter** 22.2mm
- Material & Finish** Steel•Paint Finish (Bracket)
Light Alloy•Barrel Finish (Lever)
- Attachment Position** Handlebar

SIS-Friction Mode Switch



Cantilever Brake
BR-M650

- Weight** 199g. (Pair)
- Compatibility** Shimano Total Integration Compatible, SLR (Shimano Linear Response) Compatible
- Features** Super Low Profile Design, Easy Cable Attachment, Spring Tension Adjuster
- Material & Finish** Light Alloy•Barrel Finish
- Use** For SLR system use with SLR compatible brake lever and Shimano SLR outer cable with liner.

Toe-in Adjust

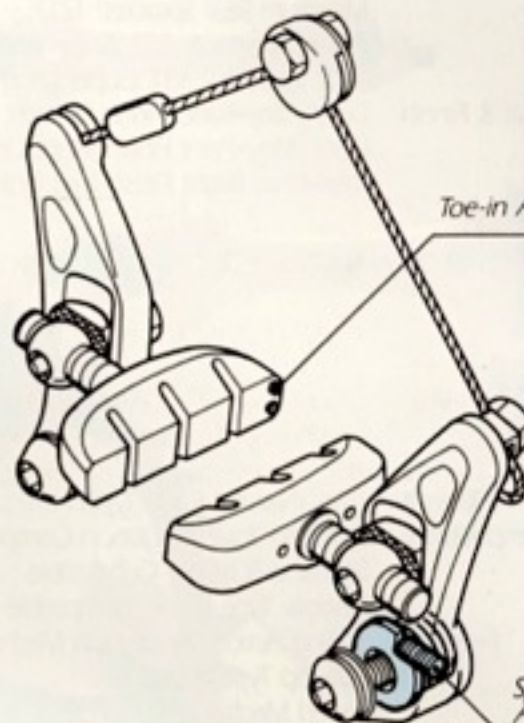

Spring Tension Adjuster

Cantilever Brake
BR-M651

- Compatibility** Shimano Total Integration Compatible, SLR (Shimano Linear Response) Compatible
- Features** Low Profile Design, Easy Cable Attachment, Spring Tension Adjuster
- Material & Finish** Light Alloy•Barrel Finish
- Use** For SLR system use with SLR compatible brake lever and Shimano SLR outer cable with liner.

Cantilever Brake
BR-MT62

- Weight** 190g. (Pair)
- Compatibility** Shimano Total Integration Compatible, SLR (Shimano Linear Response) Compatible
- Features** Easy Cable Attachment, Spring Tension Adjuster
- Material & Finish** Light Alloy•Barrel Finish (Black Finish Available)
- Use** For SLR System use with SLR Compatible brake lever and Shimano SLR outer cable with liner.

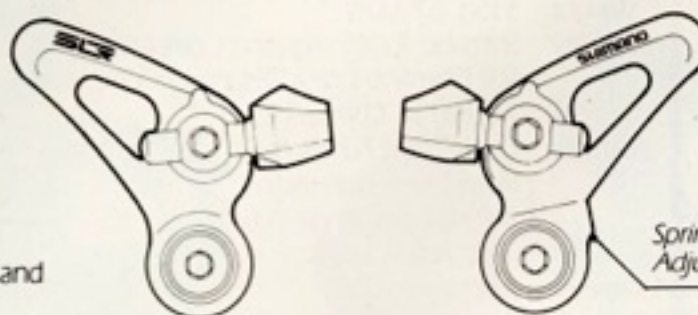

Spring Tension Adjuster

U-II Brake
BR-MT63

- Weight** 338g. (1 Unit)
- Compatibility** Shimano Total Integration Compatible,
SLR (Shimano Linear Response) Compatible
- Features** Spring Tension Adjuster,
Power Plate with Shark Tooth
- Material & Finish** Light Alloy•Anodized Finish
- Use** For SLR System use with SLR compatible brake lever and Shimano SLR outer cable with liner.

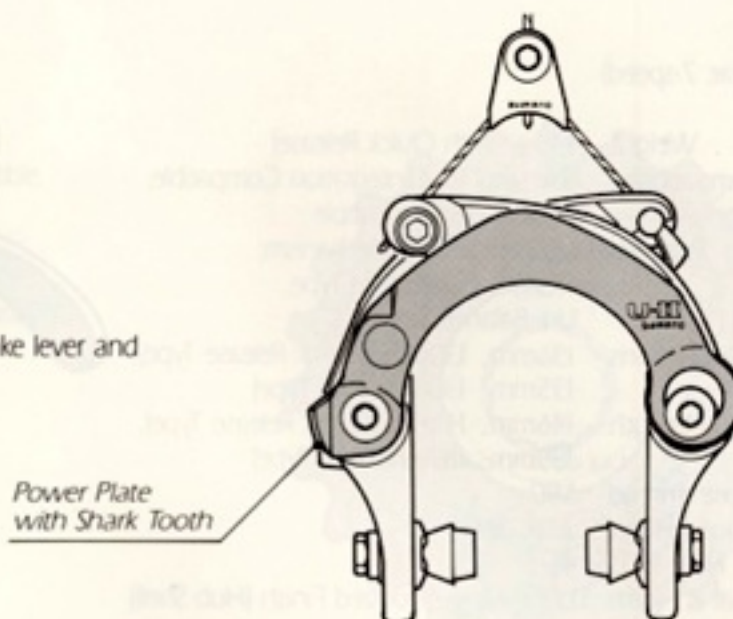

Brake Lever
BL-MT62 (4-Finger)
BL-MT63 (2-Finger)

- Weight** 274g. (Pair, BL-MT63)
- Compatibility** SLR (Shimano Linear Response) Compatible
- Features** Return Spring,
Digital Lever-Reach Adjustment (4-Positions)
- Lever Clamp Diameter** 22.2mm.
- Material & Finish** Light Alloy•Black Finish (Bracket),
Light Alloy•Anodized Finish (Lever)
- Use** For SLR system use with SLR Compatible brake and Shimano SLR outer cable with liner.

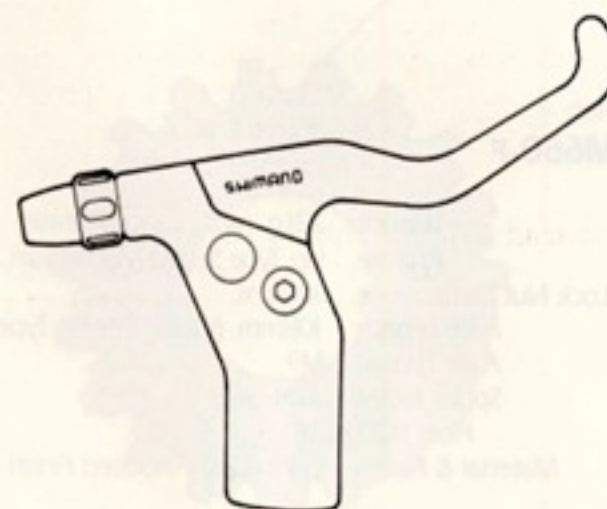

Front Chainwheel & Bottom Bracket Assembly
FC-MT60-SG (Shimano SG Triple, MD Type)
BB-MT60 (B.B. Set)

- Weight** 740g. (28T., 38T., 48T., 170mm.), 320g (B.B. Set)
- Compatibility** Shimano Total Integration Compatible,
Narrow Type Chain Compatible
- Features** Shimano SG Gear,
Sealed Mechanism (B.B.)
- Use** For 1/2" x 3/32" Chain
- Teeth Combination** 48T. x 38T. x 28T., 46T. x 36T. x 26T. (Biopace SG),
48T. x 38T. x 28T., 46T. x 36T. x 24T. (Round SG)
- Crank Length** 170mm., 175mm.
- Crank Thread** English BC 9/16" x 20T.P.I.
- Cup Thread** English BC 1.37 x 24T.P.I., French M35 x 1.0,
Italian M36 x 24T.P.I.
- B.B. Size** 70-T-122.5, 68-T-122.5, 73-T-121.5, 68-T-127.5
- Material & Finish** Light Alloy•Barrel Finish (Crank)
Light Alloy•Anodized Finish (Chainring)

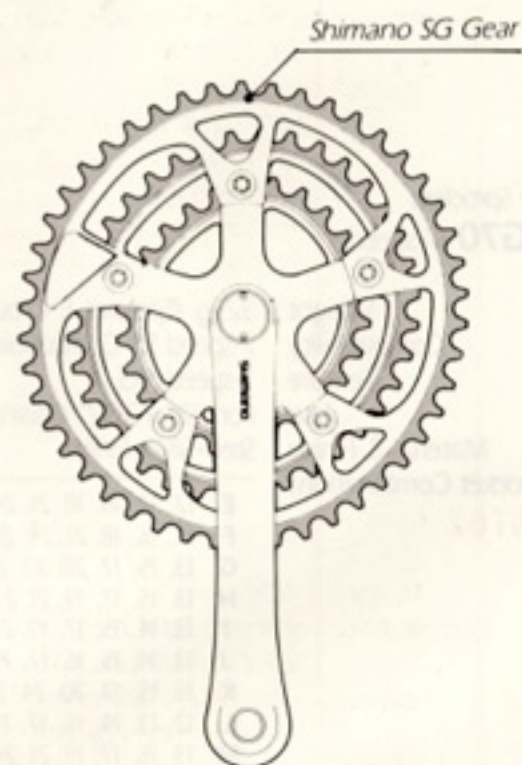

Freehub

FH-M650 (Rear, 7-speed)

Weight	445g. (with Quick Release)
Compatibility	Shimano Total Integration Compatible, 7-speed SIS Compatible
Features	Lip Type Sealed Mechanism, HG/UG Convertible Type, Uni-Balance System
Over Lock Nut Dimensions	136mm., 130mm. (Quick Release Type), 135mm., 130mm. (Nut Type)
Axle Length	146mm., 141mm. (Quick Release Type), 185mm., 180mm. (Nut Type)
Axle Thread	M10
Spoke Holes	32H, 36H
Hole PCD	45
Material & Finish	Light Alloy•Anodized Finish (Hub Shell)

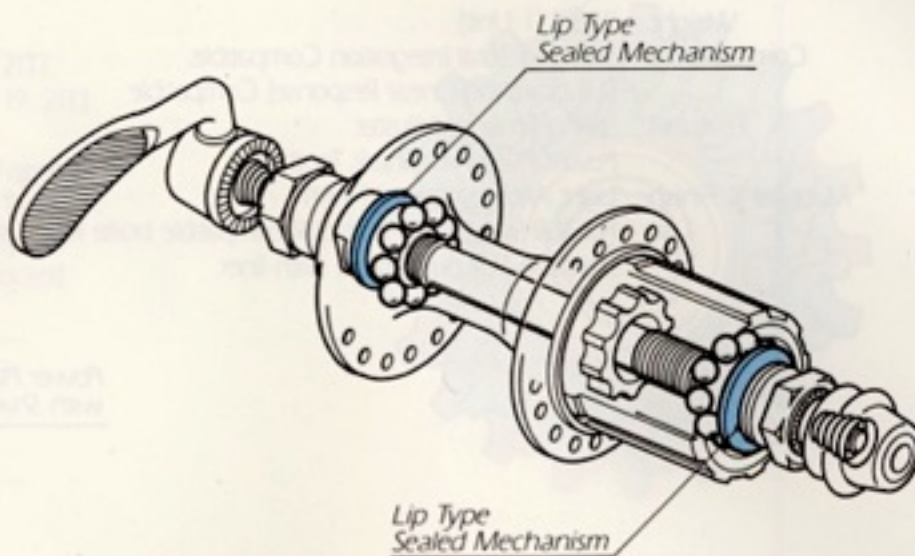

Front Hub

HB-M650-F

Weight	231g. (with Quick Release)
Feature	Lip Type Sealed Mechanism
Over Lock Nut Dimensions	100mm.
Axle Length	108mm. (Quick Release Type), 142mm. (Nut Type)
Axle Thread	M9
Spoke Holes	32H, 36H
Hole PCD	38
Material & Finish	Light Alloy•Anodized Finish (Hub Shell)

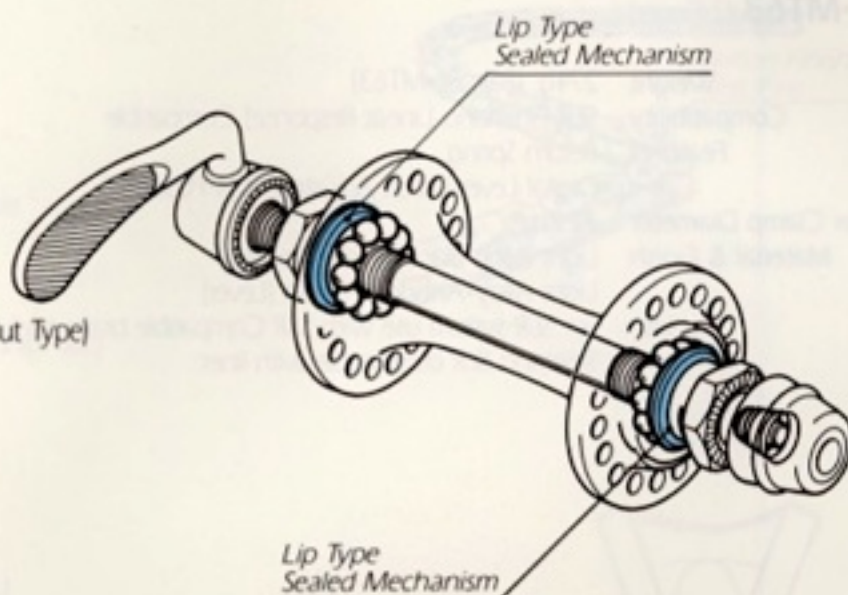

Cassette Sprockets

CS-HG70 (7-speed)

Weight	325g. (Sprocket E Group & Spacer)
Compatibility	7-speed SIS Compatible
Feature	7-speed HG
Use	For 1/2" x 3/32" Chain (Narrow Type Chain)
Material & Finish	Steel•Silver Finish
Sprocket Combinations	

E	12, 14, 16, 18, 21, 24, 28T.
F	14, 16, 18, 21, 24, 28, 32T.
G	13, 15, 17, 20, 23, 26, 30T.
H	13, 15, 17, 19, 21, 23, 26T.
I	13, 14, 15, 17, 19, 21, 23T.
J	13, 14, 15, 16, 17, 19, 21T.
K	13, 15, 17, 20, 24, 29, 34T.
L	12, 13, 14, 15, 17, 19, 21T.
M	13, 15, 17, 19, 21, 24, 28T.

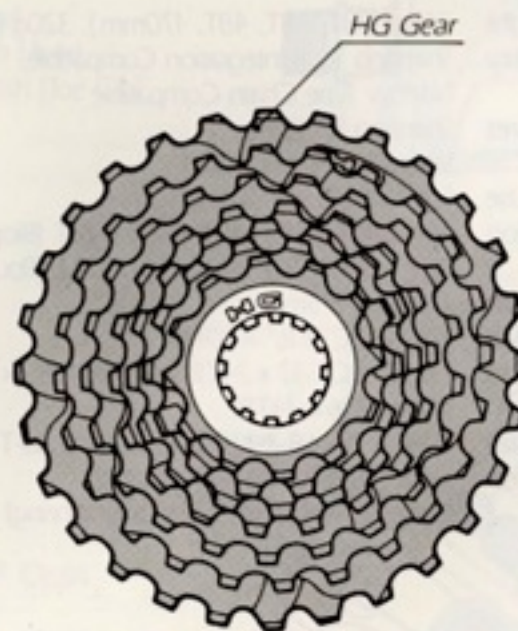

HG Chain
CN-HG70

Weight 325g. (114 Link)
Compatibility Shimano Total Integration Compatible
Features Narrow Type HG Chain,
 Chromed Finish Link Pins
Size 1/2" x 3/32"
Material & Finish Gray Finish (Roller Link Plate),
 Black Finish (Pin Link Plate)

Chromed Finish
Link Pins

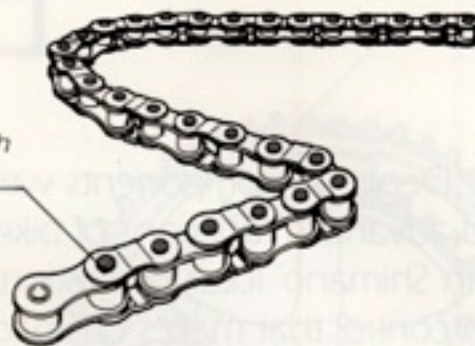

Pedal
PD-M650

Weight 385g. (Pair)
Features 32° Road Clearance,
 Super Low Profile Design,
 Parallelogram Shape,
 Contact Type Sealed Mechanism,
 Steel Grip Pin,
 Toe Clip/Reflector Attachable
Material & Finish Light Alloy (Body),
 Steel-Anodized Finish (Plate),
 Resin (Toe Clip)
Crank Thread English BC 9/16" x 20T.P.I.

Toe Clip

Contact Type
Sealed Mechanism

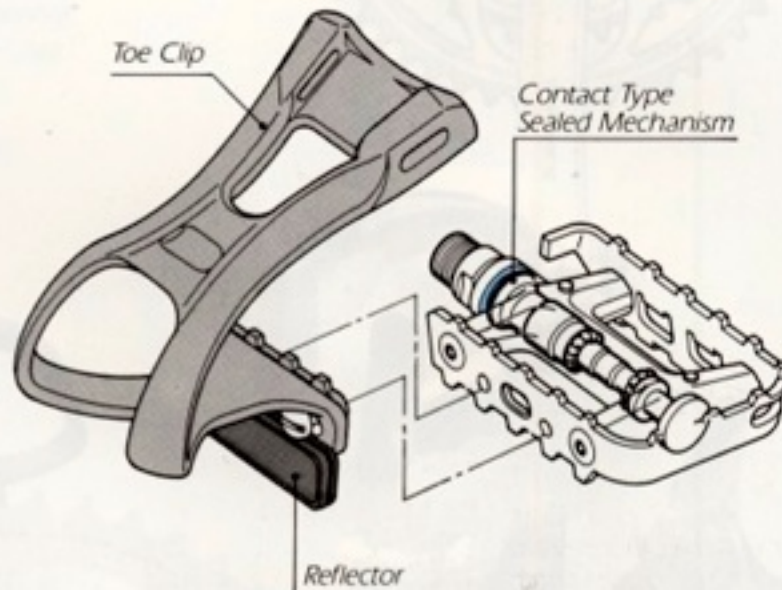

Reflector

Pedal
PD-MT60

Weight 412g. (Pair)
Features 26° Road Clearance,
 Low Profile Design,
 Parallelogram Design,
 Contact Type Sealed Mechanism,
 Steel Grip Pin,
 Toe Clip/Reflector Attachable
Material & Finish Light Alloy (Body),
 Steel-Anodized Finish (Plate)
Crank Thread English BC 9/16" x 20T.P.I.

Contact Type
Sealed Mechanism

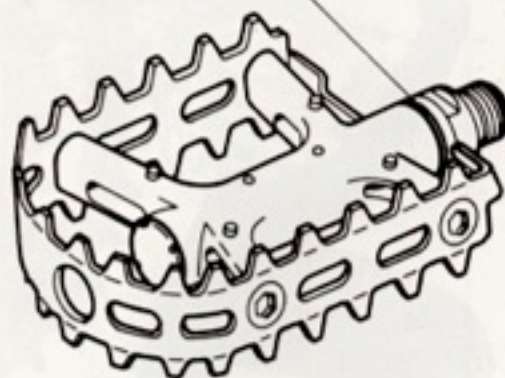

Head Parts
HP-M650
HP-M651

Weight 121g. (HP-M650), 149g. (HP-M651)
Type Off-Road Type,
Feature Sealed Mechanism
Material & Finish Steel-Black Finish

Variation & Dimensions

Type	HP-M650		HP-M651
Thread	BC1" x 24T.	M25 x P1.0	BC1-1/8" x 26T.
A	30.2mm.	30.2mm.	34.0mm.
B	26.4mm.	26.4mm.	30.0mm.
C	22.1mm.		25.5mm.
D	32.0mm.		36.0mm.
f ₁	22.0mm.		22.0mm.
f ₂	11.5mm.		11.5mm.

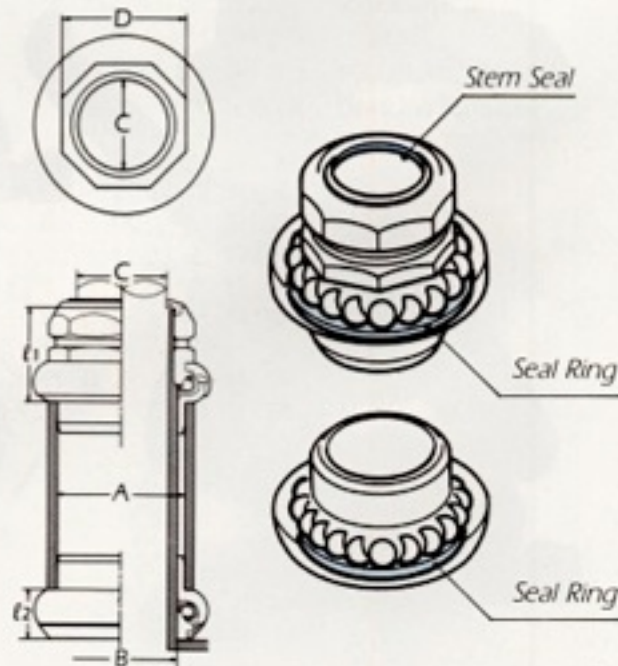

Stem Seal

Seal Ring

Seal Ring

SHIMANO DEORE LX

SHIMANO
TOTAL
INTEGRATION

The Deore LX components were developed to give the entry level off-road bike the performance and advanced functions of bikes equipped with the more expensive Shimano off-road groups. With Shimano Total Integration, Deore LX gives beginners and casual riders a feeling of stability and control that makes off-road riding as safe as it is exciting. Designed not only make a high-performance entry level mountain bike, Deore LX components also provide a high level of performance that can even satisfy accomplished off-road riders.



Rear Derailleur

RD-M550-SGS (Super Long Cage)
RD-M550-GS (Long Cage)

- Weight** 320g. (Super Long Cage)
- Compatibility** Shimano Total Integration Compatible.
6, 7-speed SIS Compatible
- Features** Sealed Link Pivots,
Centeron Guide Pulley,
Sealed Pivot & Bracket Axes,
Double Servo-Panta Mechanism,
B-Tension Adjust Bolt,
Double Spoke Barrier,
Chain Retainer (Super Long Cage)
- Capacity** Maximum Rear Sprocket: 32T. (Super Long Cage)
30T. (Short Cage)
Minimum Rear Sprocket: 12T.
Front Difference: 20T.
Total Capacity: 38T. (Super Long Cage). 30T. (Short Cage)
- Material & Finish** Light Alloy•Barrel Finish (Bracket & Plate Body),
Steel•Paint Finish (Right Link)
Steel•Pearl Bright Finish (Left Link)

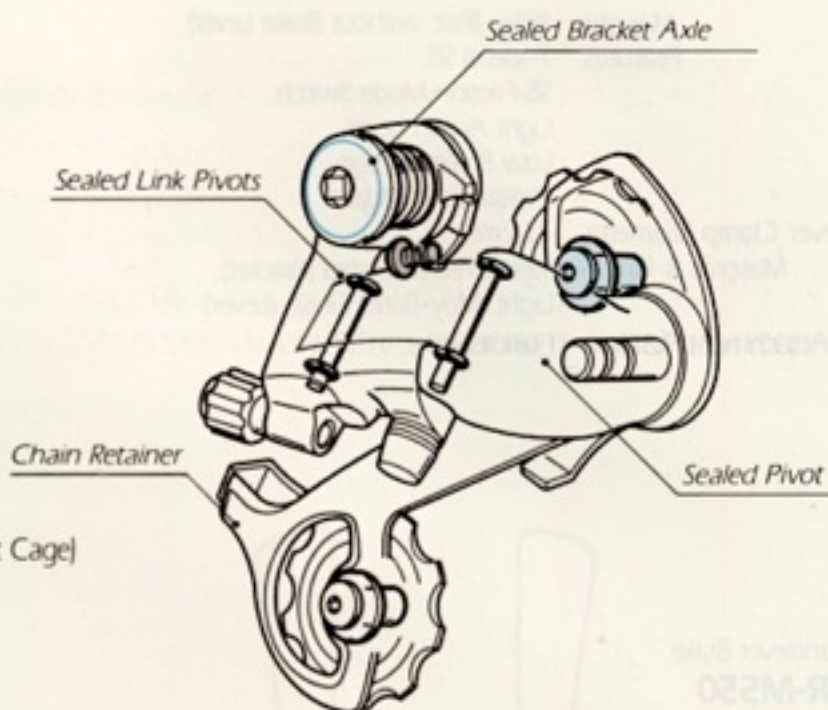

Front Derailleur

FD-M550

- Weight** 119g. (Normal Band Type)
- Compatibility** Shimano Total Integration Compatible,
Shimano SG Gear Compatible,
Narrow Type Chain Compatible
- Features** Trailing Action Pantagraph Mechanism,
Pull-Top Type Available,
Rigid Chain Guide,
New Trapease Mechanism
- Capacity** 24T. (Biopace HP), 26T. (Round)
- Clamp Diameter** Ø28.0mm. — 28.6mm., 30.0mm., 31.8mm., 34.9mm.
- Material & Finish** Light Alloy•Barrel Finish (Front & Rear Band),
Light Alloy•Paint Finish (Right Link),
Steel•Chrome-Plated (Chain Guide)

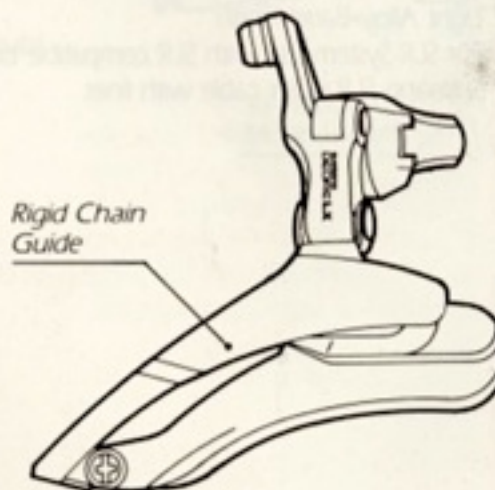

Rapidfire

ST-M060 (4-Finger)

- Weight** 326g.
- Compatibility** Shimano Total Integration Compatible,
SLR (Shimano Linear Response) Compatible,
7-speed SIS Compatible
- Features** Dual Repeat Function,
Brake Lever Stroke Adjust,
Light Action Lever
- Lever Clamp Diameter** 22.2mm.
- Material & Finish** Light Alloy•Paint Finish (Bracket),
Steel•Zinc Plated & Resin•Molding (Lever)
- Use** SLR outer casing with liner (Brake Lever) and
SIS-SP outer casing with liner (Shifting Lever)

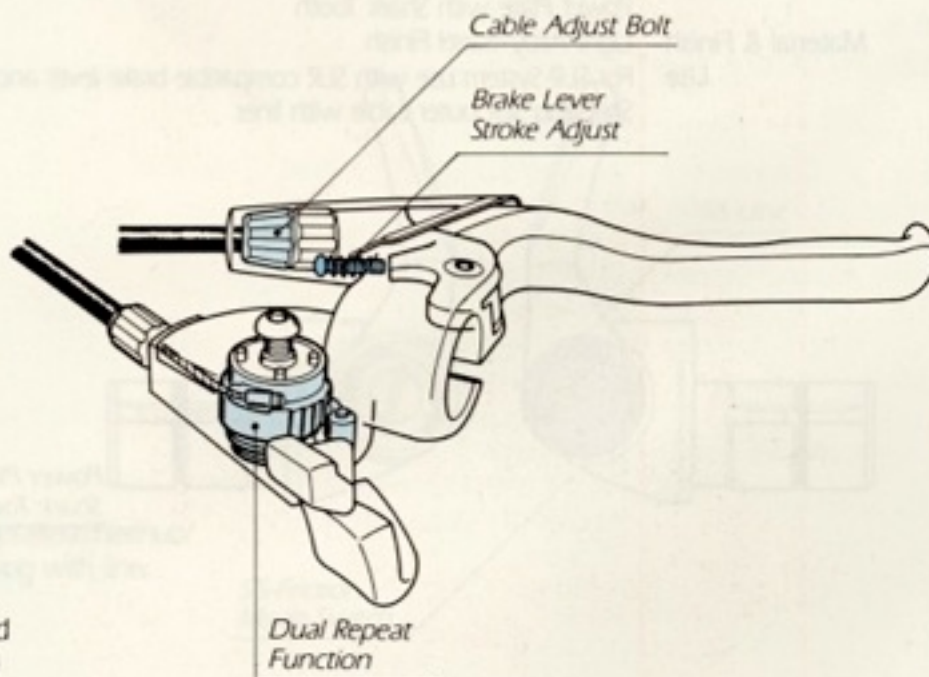

Shifting Lever
SL-M453-A

Weight	184g. (Pair, without Brake Lever)
Features	7-speed SIS, SIS-Friction Mode Switch, Light Action Lever, Low Profile Design, Digital Cable Adjust
Lever Clamp Diameter	22.2mm.
Material & Finish	Steel-Chrome Plated (Bracket), Light Alloy-Barrel Finish (Lever)
Attachment Position	Handlebar

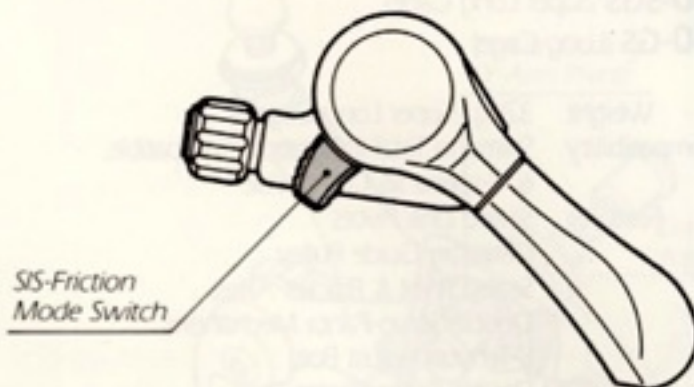

Cantilever Brake
BR-M550

Weight	216g. (Pair)
Compatibility	Shimano Total Integration Compatible, SLR (Shimano Linear Response) Compatible
Features	Easy Shoe Adjust, Internal Spring Design, Spring Tension Adjuster
Material & Finish	Light Alloy-Barrel Finish
Use	For SLR System use with SLR compatible brake lever and Shimano SLR outer cable with liner.

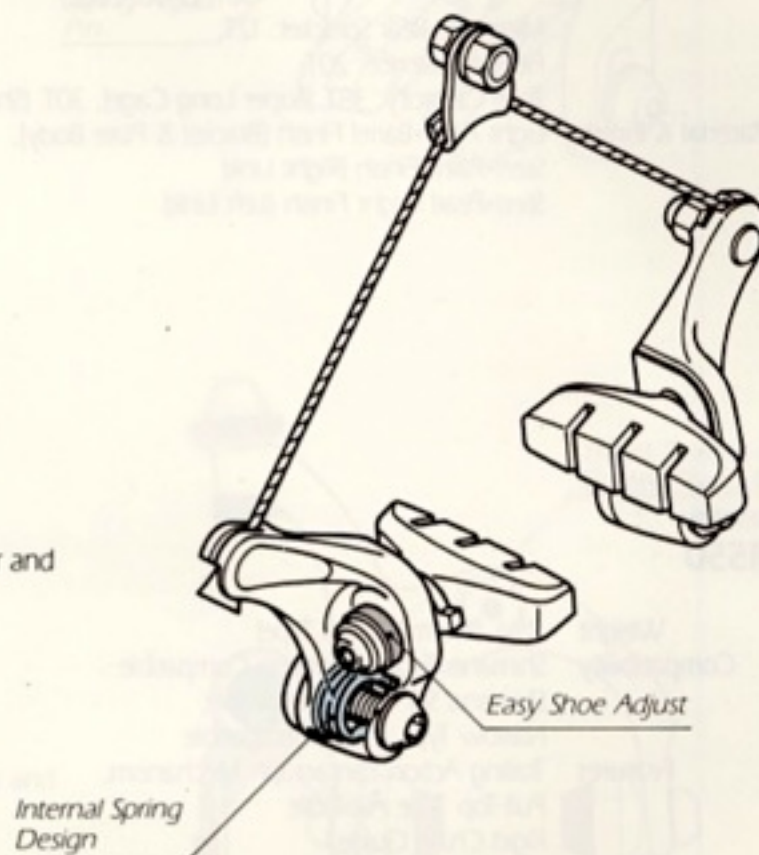

U-II Brake
BR-M453

Weight	368g. (1 Unit)
Compatibility	Shimano Total Integration Compatible, SLR (Shimano Linear Response) Compatible
Features	Spring Tension Adjuster, Power Plate with Shark Tooth
Material & Finish	Light Alloy-Barrel Finish
Use	For SLR System use with SLR compatible brake lever and Shimano SLR outer cable with liner.

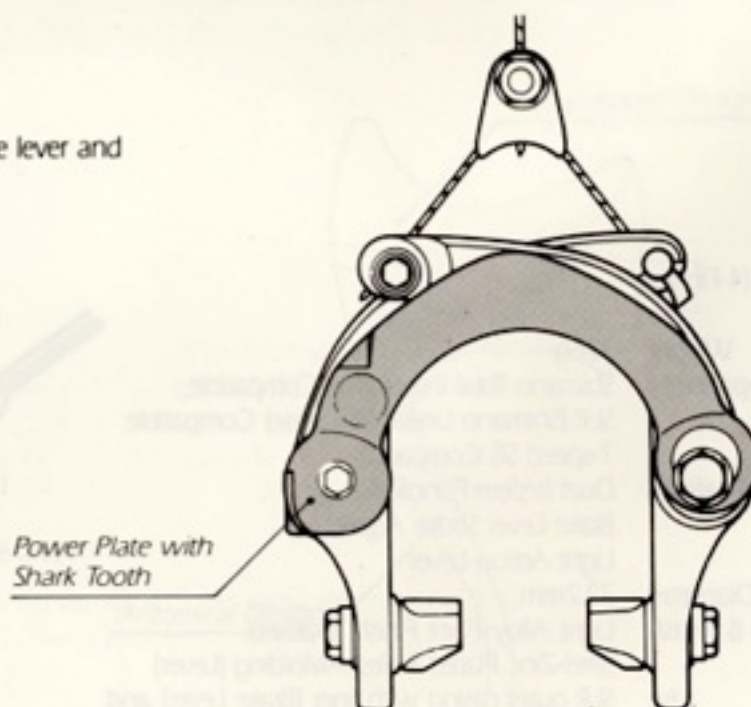

Brake Lever
BL-M451-A

- Weight 344g. (Pair, without Shifting Lever)
- Compatibility SLR (Shimano Linear Response) Compatible
- Features Return Spring, Lever Reach Adjust, Cable Adjustment
- Lever Clamp Diameter 22.2mm.
- Material & Finish Light Alloy•Paint Finish (Bracket), Light Alloy•Resin Coated (Lever)
- Use For SLR System use with SLR compatible brake and Shimano SLR outer cable with liner.

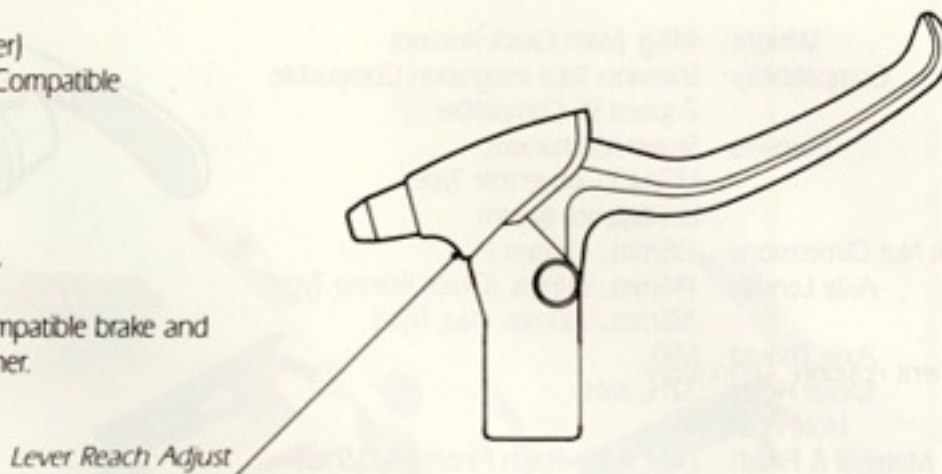

Front Chainwheel & Bottom Bracket Assembly
FC-M550-SG (Shimano SG Triple, MD Type)
BB-M550 (B.B. Set)

- Weight 752g. (28T., 38T., 48T., 170mm.), 339g. (B.B. Set)
- Compatibility Shimano Total Integration Compatible, Narrow Type Chain Compatible
- Features Shimano SG Gear, Sealed Mechanism (B.B.)
- Use For 1/2" x 3/32" Chain
- Teeth Combination 48T. x 38T. x 28T., 46T. x 36T. x 26T. (Biopace SG), 48T. x 38T. x 28T., 46T. x 36T. x 24T. (Round SG)
- Crank Length 170mm., 175mm.
- Crank Thread English BC 9/16" x 20T.P.I.
- Cup Thread English BC 1.37 x 24T.P.I., French M35 x 1.0, Italian M36 x 24T.P.I.
- B.B. Size 70-T-122.5, 68-T-122.5
- Material & Finish Light Alloy•Barrel Finish (Crank), Light Alloy•Anodized Finish (Chainring)

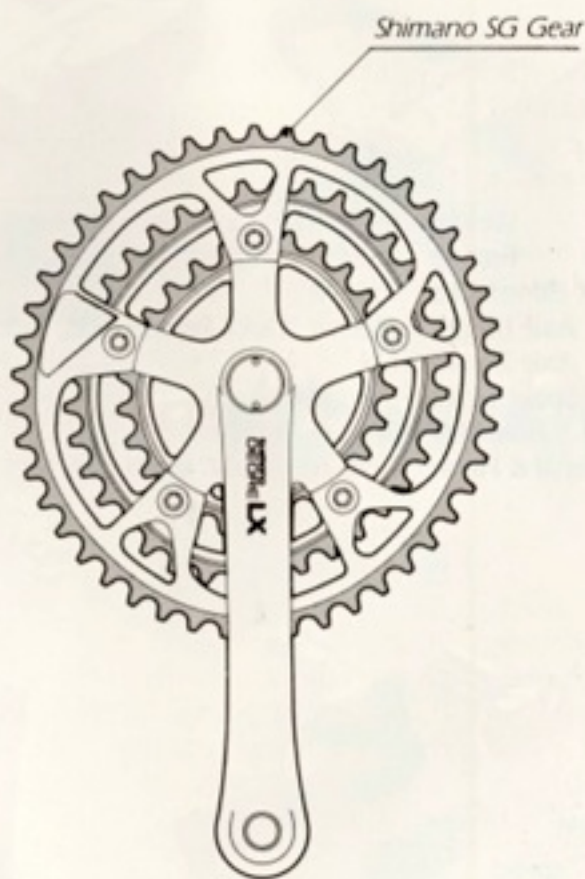

Freehub

FH-M550 (Rear, 7-speed)

Weight	445g. (with Quick Release)
Compatibility	Shimano Total Integration Compatible, 7-speed SIS Compatible
Features	Sealed Mechanism, HG/UG Convertible Type, Uni-Balance System
Over Lock Nut Dimensions	135mm., 130mm.
Axle Length	146mm., 141mm. (Quick Release Type), 185mm., 180mm. (Nut Type)
Axle Thread	M10
Spoke Holes	32H, 36H
Hole PCD	45
Material & Finish	Light Alloy•Polish Finish (Hub Shell)

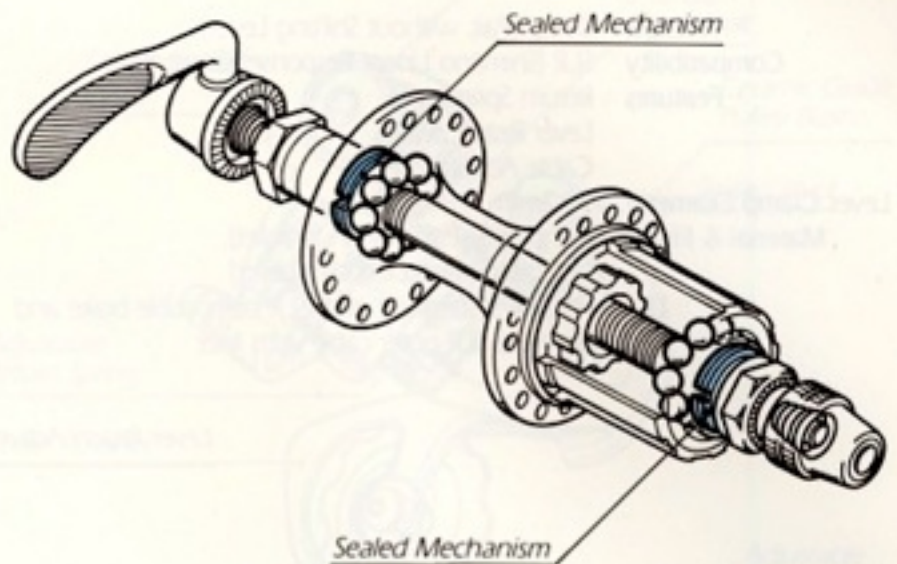

Front Hub

HB-M550-F

Weight	230g. (with Quick Release)
Feature	Sealed Mechanism
Over Lock Nut Dimensions	100mm.
Axle Length	108mm. (Quick Release Type), 140mm. (Nut Type)
Axle Thread	M9
Spoke Holes	32H, 36H
Hole PCD	38
Material & Finish	Light Alloy•Polish Finish (Hub Shell)

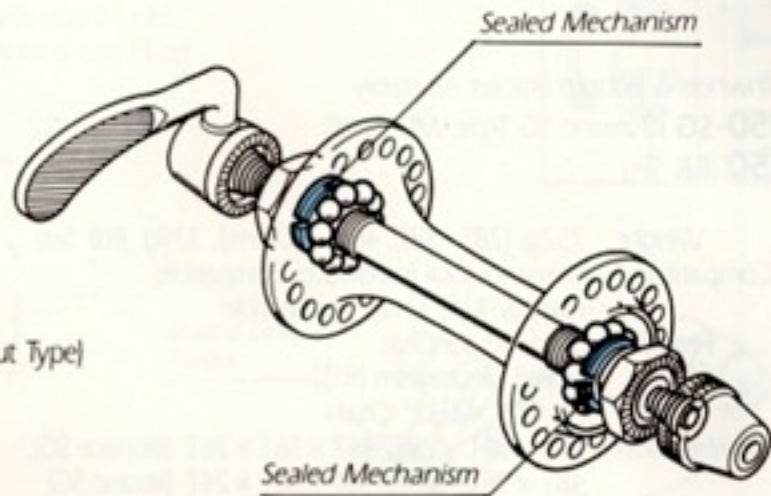

Cassette Sprockets

CS-HG70 (7-speed)

Weight	325g. (Sprocket E Group & Spacer)
Compatibility	7-speed SIS Compatible
Feature	7-speed HG
Use	For 1/2" x 3/32" Chain (Narrow Type Chain)
Material & Finish	Steel•Silver Finish
Sprocket Combinations	

E	12, 14, 16, 18, 21, 24, 28T.
F	14, 16, 18, 21, 24, 28, 32T.
G	13, 15, 17, 20, 23, 26, 30T.
H	13, 15, 17, 19, 21, 23, 26T.
I	13, 14, 15, 17, 19, 21, 23T.
J	13, 14, 15, 16, 17, 19, 21T.
K	13, 15, 17, 20, 24, 29, 34T.
L	12, 13, 14, 15, 17, 19, 21T.
M	13, 15, 17, 19, 21, 24, 28T.

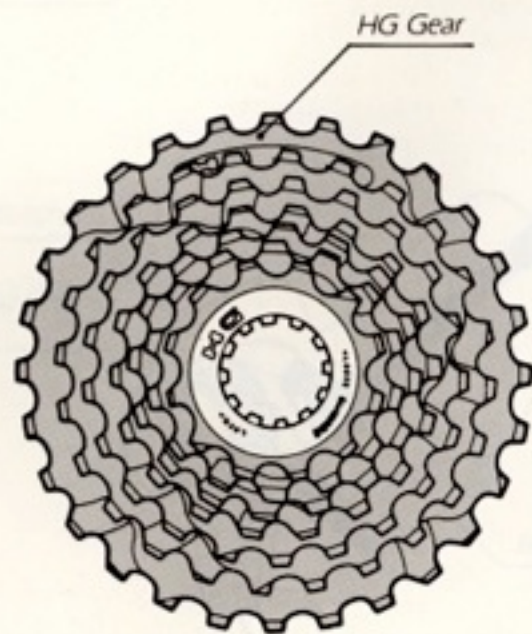

HG Chain
CN-HG70

- Weight 325g. (114 Link)
- Compatibility Shimano Total Integration Compatible
- Features Nararow Type HG Chain,
Chromed Finish Link Pins
- Size 1/2" x 3/32"
- Material & Finish Gray Finish (Roller Link Plate),
Black Finish (Pin Link Plate)

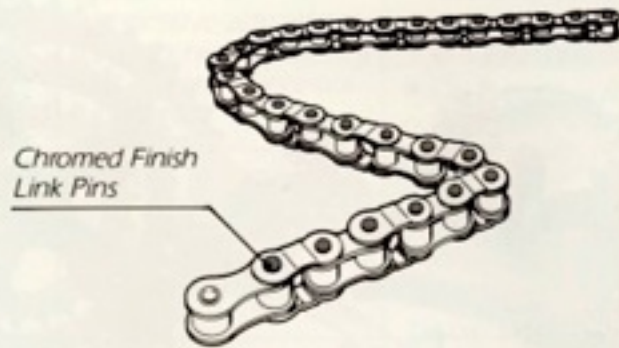

Pedal
PD-M550

- Weight 326g. (Pair)
- Features 30° Road Clearance,
Super Low Profile Design,
Parallelogram Shape,
Toe Clip/Reflector Attachable
- Material & Finish Resin (Body),
Steel-Anodized Finish (Plate),
Resin (Toe Clip)
- Crank Thread English BC 9/16" x 20T.P.I.

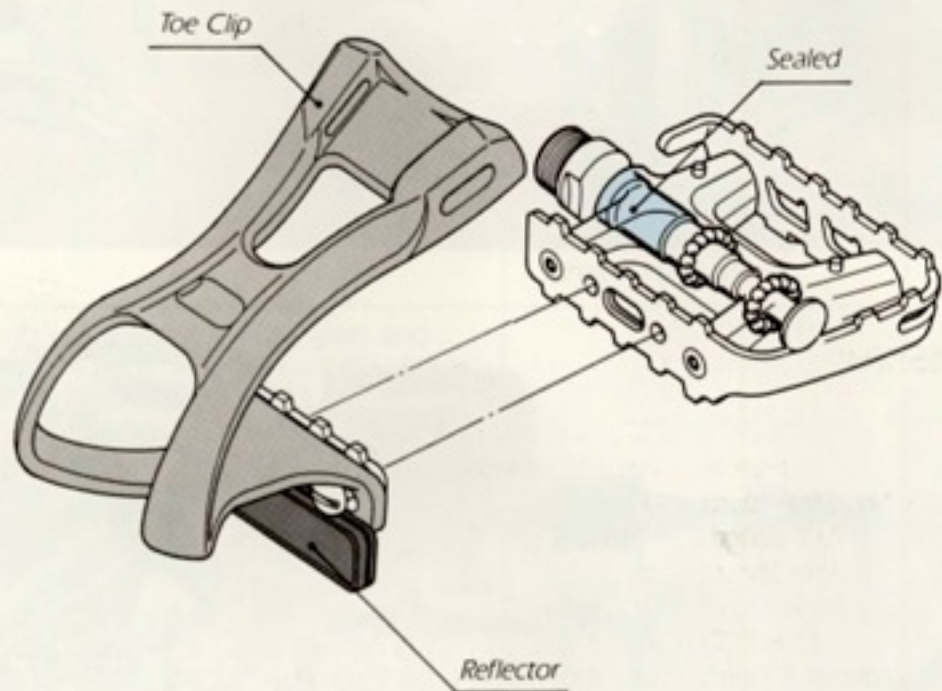

Head Parts
HP-R500

- Weight 121g.
- Type Off-Road Type
- Feature Sealed Mechanism
- Material Steel (Lock Nut),
Resin (Upper & Lower Cup)
- Color Variation White, Silver, Black

Type	Thread	Press Race Diameter	
		Upper Cone & Lower Cup	Lower Cone
English/Italian	BC1 x 24T.	30.2mm.	26.4mm.
French	M25 x P1.0	30.2mm.	26.4mm.

Dimensions

t ₁	22.0mm.
t ₂	11.5mm.
H	Head Tube Length
A	22.3mm.
B	30.2mm.
C	26.4mm.
Thread	BC 1" x 24T. (English Thread)/ M25" x P1.0 (French Thread)

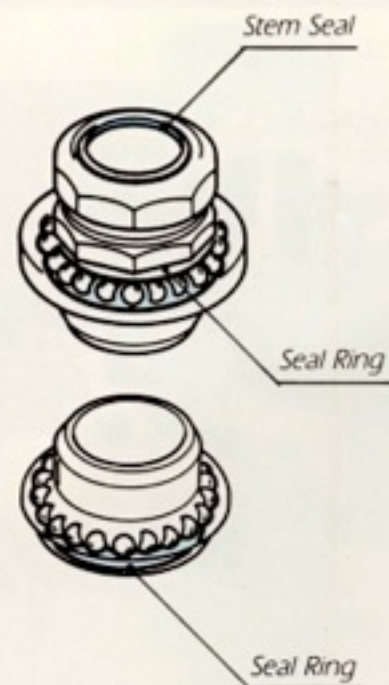
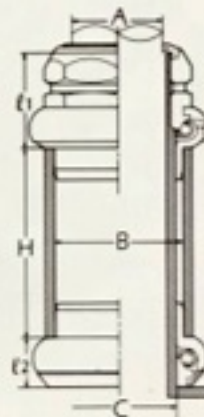

EXAGE LX

SHIMANO
TOTAL
INTEGRATION



EXAGE
500 LX



EXAGE
400 LX



EXAGE
300 LX

Exage 500LX

Exage 500LX

Model No.	Specifications	Features	Material • Finish	Note																									
Rear Derailleur RD-M500-SGS (Super Long Cage) RD-M500-GS (Long Cage)	6 & 7-speed SIS Compatible Max. Rear Sprocket: 32T. (SGS), 30T. (GS) Min. Rear Sprocket: 12T. (SGS, GS) Front Difference: 20T. (SGS, GS) Total Capacity: 38T. (SGS), 36T. (GS) 329g. (SGS)	Cable Saver Arm Double Servo-Panta Mechanism Centeron Guide Pulley Double Spoke Barrier B-Tension Adjuster Sealed Mechanism Sintered Alloy Guide Pulley Bushing Chain Retainer	Bracket Body: Light Alloy • Paint Finish Right Link: Steel • Paint Finish Left Link: Steel • Pearl Bright Finish Plate Body: Light Alloy • Paint Finish	SIS Compatible Detachable Bracket Available																									
Front Derailleur FD-M500-B (Band Type) FD-M500 (EC Type)	Shimano SG Gear Compatible Narrow Type Chain Compatible Capacity: 24T. (Biopace HP) 26T. (Round) Band Diameter: ø28.0-ø28.6, ø30.0, ø31.8mm. (Band Type) ø28.0-ø28.6, ø30.0, ø31.8, ø34.9mm. (EC Type) 118g. (Band Type)	Trailing Action Pantograph Mechanism Rigid Chainguide New Tapease Mechanism	Front Band: Light Alloy • Paint Finish Rear Band: Light Alloy • Paint Finish Right Link: Light Alloy • Paint Finish Chainguide: Chrome Plated																										
Rapidfire ST-M050 (4-Finger) ST-M050-s (3-Finger)	7-speed SIS Compatible SLR (Shimano Linear Response) Compatible Lever Clamp Diameter: 22.2mm. 305g. (4-Finger Type)	Dual Repeat Function Light Action Lever Anatomical Design Brake Lever Stroke Adjust Brake Lever Cable Adjust	Bracket: Light Alloy • Paint Finish Lever: Steel • Zinc Plated Resin • Molding	Use with Shimano SIS-SP Cable With Liner																									
Cantilever Brake BR-M454	SLR (Shimano Linear Response) Compatible 216g. (Pair)	Rigid Computer Designed Shape Sealed Internal Spring Design Easy Cable Attachment Spring Tension Adjuster	Light Alloy • Barrel Finish	For SLR System use Rapidfire or SLR Compatible Brake Lever and Shimano Outer Cable with Liner.																									
U-II Brake BR-M453 (with Booster)	SLR (Shimano Linear Response) Compatible 368g. (1 unit)	Pre-Road Spring Design Sealed Internal Spring Design Rigid Computer Designed Shape Spring Tension Adjuster	Light Alloy • Barrel Finish	For SLR System use Rapidfire or SLR Compatible Brake Lever and Shimano Outer Cable with Liner.																									
Brake Lever BL-M451-A (4-Finger)	SLR (Shimano Linear Response) Compatible Shifting Lever Unit Type Lever Clamp Diameter: 22.2mm. 340g. (Pair)	Light Action Lever Lever Stroke Adjust Anatomical Design	Bracket: Light Alloy • Anodized Finish Lever: Light Alloy • Barrel Finish	For SLR System use SLR Compatible Brake and Shimano Outer Cable with Liner.																									
Front Chainwheel FC-M500-SG (Shimano SG Gear, Triple MD Type) Bottom Bracket Assembly BB-M500	Shimano SG Gear Narrow Type Chain Compatible Crank Length: 170mm., 175mm. Teeth: <table border="1" style="margin-left: 20px;"> <thead> <tr> <th></th> <th>Biopace</th> <th colspan="2">Round</th> </tr> </thead> <tbody> <tr> <td>Top</td> <td>48T</td> <td>48T</td> <td>46T</td> </tr> <tr> <td>Middle</td> <td>38T</td> <td>38T</td> <td>36T</td> </tr> <tr> <td>Low</td> <td>28T</td> <td>28T</td> <td>24T</td> </tr> </tbody> </table> Crank Thread: English BC 9/16" × 20T.P1. Cup Thread: English BC 1.37 × 24T.P1., French M35 × 1.0, Italian M36 × 24T.P1. 756g. (28T., 38T., 48T., 170mm.) 339g. (B.B. Set)		Biopace	Round		Top	48T	48T	46T	Middle	38T	38T	36T	Low	28T	28T	24T	Computer Aided Design (Crank) Sealed Mechanism (B.B.)	Crank Arm: Light Alloy • Barrel Finish Chain Ring: Light Alloy • Anodized Finish	Spindle: <table border="1" style="margin-left: 20px;"> <thead> <tr> <th>Mark</th> <th>SPL</th> <th>3PL</th> </tr> </thead> <tbody> <tr> <td>Width</td> <td>70</td> <td>68</td> </tr> <tr> <td>Length</td> <td>121</td> <td>121</td> </tr> </tbody> </table>	Mark	SPL	3PL	Width	70	68	Length	121	121
	Biopace	Round																											
Top	48T	48T	46T																										
Middle	38T	38T	36T																										
Low	28T	28T	24T																										
Mark	SPL	3PL																											
Width	70	68																											
Length	121	121																											
Freehub FH-HG50	7-speed SIS Compatible UG/HG Compatible Type Spoke Holes: 36H., 32H. Hole PCD: 45 <table border="1" style="margin-left: 20px;"> <thead> <tr> <th>O.L.D.</th> <th>135</th> <th>130</th> <th>126</th> </tr> </thead> <tbody> <tr> <td>Axle Length</td> <td>146</td> <td>141</td> <td>137</td> </tr> <tr> <td>Mounting Type</td> <td>Quick Release</td> <td colspan="2">Nut</td> </tr> </tbody> </table> Axle Thread: 10mm. 435g. (7-speed w/Quick Release)	O.L.D.	135	130	126	Axle Length	146	141	137	Mounting Type	Quick Release	Nut		Uni-Balance System Resin Sealed Mechanism (Choice) One-Piece Forged Hub Body	Light Alloy • Du-Cut Finish														
O.L.D.	135	130	126																										
Axle Length	146	141	137																										
Mounting Type	Quick Release	Nut																											
Front Hub HB-RM50-F	Spoke Holes: 36H., 32H. Hole PCD: 38 <table border="1" style="margin-left: 20px;"> <thead> <tr> <th>O.L.D.</th> <th>100</th> <th>96</th> </tr> </thead> <tbody> <tr> <td>Axle Length</td> <td>108</td> <td>104</td> </tr> <tr> <td>Mounting Type</td> <td colspan="2">Quick Release</td> </tr> </tbody> </table> Axle Thread: 9mm 228g.	O.L.D.	100	96	Axle Length	108	104	Mounting Type	Quick Release		Resin Sealed Mechanism (Choice) One-Piece Forged Hub Body	Light Alloy • Du-Cut Finish																	
O.L.D.	100	96																											
Axle Length	108	104																											
Mounting Type	Quick Release																												
Cassette Sprockets CS-HG50 (7-Speed)	7-speed SIS Compatible 7-speed HG Use Narrow Type Chain 268g. (Sprocket I Group)		Steel • Brown Finish & Silver Finish (Low Gear)	Cassette Sprocket Combinations: E 12, 14, 16, 18, 21, 24, 28T. F 14, 16, 18, 21, 24, 28, 32T. G 13, 15, 17, 20, 23, 26, 30T. H 13, 15, 17, 19, 21, 23, 26T. I 13, 14, 15, 17, 19, 21, 23T. J 13, 14, 15, 16, 17, 19, 21T. K 13, 15, 17, 20, 24, 29, 34T. L 12, 13, 14, 15, 17, 19, 21T. M 13, 15, 17, 19, 21, 24, 28T.																									
Pedal PD-M450	MTB Type Crank Thread: English BC 9/16" × T.P1. Top Clip Locking System: 2-screw 518g. (Pair)	30° Road Clearance Sealed Mechanism Low Profile Design Reflector (Option)	Body: Resin Plate: Steel • Paint Finish																										
Chain CN-HG50 Head Parts HP-R500	See Page 42																												

Exage 400LX

Exage 400LX

Model No.	Specifications	Features	Material• Finish	Note												
Rear Derailleur RD-M400-sgs (Super Long Cage) RD-M400-gs (Long Cage) RD-M400-ss (Short Cage)	6 & 7-speed SS Compatible Max. Rear Sprocket: 32T. (SGS), 30T. (GS), 28T. (SS) Min. Rear Sprocket: 12T. (SGS, GS, SS) Front Difference: 20T. (SGS, GS), 13T. (SS) Total Capacity: 38T. (SGS), 36T. (GS), 28T. (SS) 330g. (SGS)	Cable Saver Arm Double Sarvo-Panta Mechanism Centeron Guide Pulley Double Spoke Barrier B-Tension Adjuster Sealed Pivot Axle Sealed Link Pivot Heat Treated Steel in Link Pivot Sintered Alloy Guide Pulley Bushing Chain Retainer (GS, SGS, Type)	Bracket Body: Light Alloy•Barrel Finish Right Link: Steel•Paint Finish Left Link: Steel•Zinc Plated Plate Body: Light Alloy•Barrel Finish	Rivet Type Bracket Available SS Compatible Detachable Bracket Available												
Front Derailleur FD-M400-B (Band Type) FD-M400 (EC Type)	Shimano SG Gear Compatible Narrow Type Chain Compatible Capacity: 24T. (Biopace HP), 26T. (Round) Band Diameter: φ28.0—28.6, φ30.0mm. 31.8mm (Band Type) φ28.0—28.6, φ30.0, φ34.9mm (EC Type) Stroke (CL=47.5) 35—55 132g. (Band Type)	Trailing Action Pantagraph Mechanism Rigid Chainguide Sealed Mechanism New Trapease Mechanism	Front Band: Steel•Pearl Bright Finish Rear Band: Light Alloy•Barrel Finish Right Link: Light Alloy•Paint Finish Chainguide: Chrome Plated													
Rapidfire ST-M050 (4-Finger) ST-M050-s (3-Finger)	7-Speed SS Compatible SLR (Shimano Linear Response) Compatible Lever Clamp Diameter: 22.2mm. 305g. (4-Finger Type Rear)	Dual Repeat Function Light Action Lever Anatomical Design Brake Lever Stroke Adjust Brake Lever Cable Adjust	bracket: Light Alloy•Paint Finish Lever: Steel•Zinc Plated Resin•Molding	Use with Shimano SS-SP Cable with Liner												
Shifting Lever SL-M453 (7-Speed)	7-Speed SS Compatible Lever Clamp Diameter: 22.2mm. 184g. (Pair)	Light Action Lever Anatomical Design	Bracket: Light Alloy•Anodized Finish Lever: Light Alloy•Barrel Finish	Use with Shimano SS-SP Cable with Liner												
Cantilever Brake BR-M351 (Standard Type) BR-M352 (For Short Frame, Rear only)	SLR (Shimano Linear Response) Compatible 227g. (Pair, BR-M351)	Rigid Computer Designed Shape Sealed Internal Spring Design Spring Tension Adjuster Low Profile Brake Shoe	Steel & Resin	For SLR System use with Rapidfire or SLR Compatible Brake Lever and Shimano Outer Cable with Liner.												
Brake BL-M350-B (4-Finger)	SLR (Shimano Linear Response) Compatible Lever Clamp Diameter: 22.2mm. 294g. (Pair)	Light Action Lever Sealed Mechanism Anatomical Design Dust Cover	Bracket: Steel•Resin Covered & Resin Lever: Steel•Resin Corted & Resin	For SLR System use with SLR Compatible Brake and Shimano Outer Cable with Liner.												
Front Chainwheel FC-M400-SG (Shimano SG Gear, Triple MD Type) Bottom Bracket Assembly BB-M500	Shimano SG Gear Narrow Type Chain Compatible Crank Length: 170mm., 175mm. Teeth (Biopace): 48T, 38T, 28T. Crank Thread: English BC 9/16" × 20T.P.I. Cup Thread: English BC 1.37 × 24T.P.I., French M35 × 1.0, Italian M36 × 24T.P.I. 763g. (28T., 38T., 48T., 170mm.) 339g. (B.B. Set)	Computer Aided Design (Crank) Sealed Mechanism (B.B.)	Crank Arm: Light Alloy•Barrel Finish Chain Ring: Steel•Paint Finish	Spindle: <table border="1"> <tr> <td>Mark</td> <td>5PL</td> <td>3PL</td> </tr> <tr> <td>Width</td> <td>70</td> <td>68</td> </tr> <tr> <td>Length</td> <td>121</td> <td>121</td> </tr> </table>	Mark	5PL	3PL	Width	70	68	Length	121	121			
Mark	5PL	3PL														
Width	70	68														
Length	121	121														
Freewheel FH-HG50	7-speed SS Compatible UG/HG Compatible Type Spoke Holes: 36H., 32H. Hole PCD: 45 <table border="1"> <tr> <td>O.L.D.</td> <td>135</td> <td>130</td> <td>126</td> </tr> <tr> <td>Axle Length</td> <td>146</td> <td>141</td> <td>137</td> </tr> <tr> <td>Mounting Type</td> <td>Quick Release</td> <td>Nut</td> <td></td> </tr> </table> Axle Thread: 10mm. 435g. (7-speed w/Quick Release)	O.L.D.	135	130	126	Axle Length	146	141	137	Mounting Type	Quick Release	Nut		Uni-Balance System Resin Sealed Mechanism (Choice) One-Piece Forged Hub Body	Light Alloy•Dia-Cut Finish	
O.L.D.	135	130	126													
Axle Length	146	141	137													
Mounting Type	Quick Release	Nut														
Front Hub HB-RM50-F	Spoke Holes: 36H., 32H. Hole PCD: 38 <table border="1"> <tr> <td>O.L.D.</td> <td>100</td> <td>96</td> </tr> <tr> <td>Axle Length</td> <td>108</td> <td>104</td> </tr> <tr> <td>Mounting Type</td> <td>Quick Release</td> <td></td> </tr> </table> Axle Thread: 9mm 228g.	O.L.D.	100	96	Axle Length	108	104	Mounting Type	Quick Release		Resin Sealed Mechanism (Choice) One-Piece Forged Hub Body	Light Alloy•Dia-Cut Finish				
O.L.D.	100	96														
Axle Length	108	104														
Mounting Type	Quick Release															
Cassette Sprockets CS-HG50 (7-Speed)	7-speed SS Compatible 7-speed HG Use Narrow Type Chain 268g. (Sprocket I Group)		Steel•Brown Finish & Silver Finish (Low Gear)	Cassette Sprocket Combinations: E 12, 14, 16, 18, 21, 24, 28T. F 14, 16, 18, 21, 24, 28, 32T. G 13, 15, 17, 20, 23, 26, 30T. H 13, 15, 17, 19, 21, 23, 26T. I 13, 14, 15, 17, 19, 21, 23T. J 13, 14, 15, 16, 17, 19, 21T. K 13, 15, 17, 20, 24, 29, 34T. L 12, 13, 14, 15, 17, 19, 21T. M 13, 15, 17, 19, 21, 24, 28T.												
Pedal PD-M350	MTB Type Crank Thread: English BC 9/16" × T.P.I. Top Clip Locking System: 2-screw 445g. (Pair)	26° Road Clearance Sealed Mechanism Low Profile Design w/Reflector	Body: Resin•Paint Finish Plate: Steel•Paint Finish													
Chain CN-HG50 Head Parts HP-R500	See Page 42															

Exage 300LX

Model No.	Specifications	Features	Material•Finish	Note
Rear Derailleur RD-M300-sgs (Super Long Cage) RD-M300-GS (Long Cage)	6 & 7-speed SS Compatible Max. Rear Sprocket: 32T. (SGS), 30T. (GS) Min. Rear Sprocket: 12T. (SGS, GS) Front Difference: 20T. (SGS, GS) Total Capacity: 38T. (SGS), 36T. (GS) 319g. (SGS)	Cable Saver Arm Double Servo-Pants Mechanism Centeron Guide Pulley Double Spoke Barner B-Tension Adjuster Sealed Mechanism Sintered Alloy Guide Pulley Bushing Chain Retainer	Bracket Body: Light Alloy•Barrel Finish Right Link: Steel•Zinc Plated Resin•Molding Left Link: Steel•Zinc Plated Plate Body: Resin•Molding	Rivet Type Bracket Available SS Compatible Detachable Bracket Available
Front Derailleur FD-M300-B (Band Type) FD-M300 (EC Type)	Shimano SG Gear Compatible Narrow Type Chain Compatible Capacity: 24T. (Biopace HP) 26T. (Round) Band Diameter: φ28.0-φ28.6, φ30.0, φ31.8mm. (Band Type) φ28.0-φ28.6, φ30.0, φ34.9mm. (EC Type) Stroke (CL=47.5): 35-55 135g. (Band Type)	Trailing Action Pantograph Mechanism Rigid Chainguide New Trapease Mechanism	Front Band: Steel•Pearl Bright Finish Rear Band: Light Alloy•Barrel Finish Right Link: Steel•Paint Finish Chainguide: Chrome Plated	
Rapidfire ST-M050 (4-Finger) ST-M050-s (3-Finger)	7-speed SS Compatible SLR (Shimano Linear Response) Compatible Lever Clamp Diameter: 22.2mm. 305g. (4-Finger Type)	Dual Repeat Function Light Action Lever Anatomical Design Brake Lever Stroke Adjust Brake Lever Cable Adjust	Bracket: Light Alloy•Paint Finish Lever: Steel•Zinc Plated Resin•Molding	Use with Shimano SS-SP Cable With Liner
Shifting Lever SL-M300-B (7-Speed, Separate Type) SL-M300-C (7-Speed, Unit Type)	7-Speed SS Compatible Lever Clamp Diameter: 22.2mm.	Light Action Lever Anatomical Design	Bracket: Steel•Paint Finish Lever: Resin•Molding	Use with Shimano SS-SP Cable With Liner
Cantilever Brake BR-M250	SLR (Shimano Linear Response) Compatible 235g. (Pair)	Rigid Computer Designed Shape Sealed Internal Spring Design Easy Cable Attachment Spring Tension Adjuster	Steel & Resin	For SLR System use with Rapidfire or SLR Compatible Brake Lever and Shimano Outer Cable with Liner.
Brake Lever BL-M250-C (4-Finger)	SLR (Shimano Linear Response) Compatible Lever Clamp Diameter: 22.2m. 362g. (Pair)	Light Action Lever Anatomical Design	Bracket: Steel•Resin Covered & Resin Lever: Steel•Resin Covered & Resin	For SLR System use SLR with Compatible Brake and Shimano Outer Cable with Liner.
Front Chainwheel FC-M300-SG (Shimano SG Gear, Triple MD Type) Bottom Bracket Assembly BB-M500	Shimano SG Gear Narrow Type Chain Compatible Crank Length: 170mm., 175mm. Teeth (Biopace): 48T.-38T.-28T. Crank Thread: English BC 9/16" x 20T.P.I. Cup Thread: English BC 1.37 x 24T.P.I., French M35 x 1.0, Italian M36 x 24T.P.I. 756g. (28T., 38T., 48T., 170mm.) 339g. (B.B. Set)	Computer Aided Design (Crank) Sealed Mechanism (B.B.)	Crank Arm: Light Alloy•Paint Finish Chain Ring: Steel•Paint Finish	Spindle: Mark 5PL 3PL Width 70 68 Length 121 121
Freehub FH-HG50	7-speed SS Compatible UG/HG Compatible Type Spoke Holes: 36H., 32H. Hole PCD: 45 O.L.D. 135 130 126 Axle Length 146 141 137 Mounting Type Quick Release Nut Axle Thread: 10mm. 435g. (7-speed w/Quick Release)	Uni-Balance System Resin Sealed Mechanism (Choice) One-Piece Forged Hub Body	Light Alloy•Dia-Cut Finish	
Front Hub HB-RM50-F	Spoke Holes: 36H., 32H. Hole PCD: 38 O.L.D. 100 96 Axle Length 108 104 Mounting Type Quick Release Axle Thread: 9mm 228g.	Resin Sealed Mechanism (Choice) One-Piece Forged Hub Body	Light Alloy•Dia-Cut Finish	
Cassette Sprockets CS-HG50 (7-Speed)	7-speed SS Compatible 7-speed HG Use Narrow Type Chain 268g. (Sprocket I Group)		Steel•Brown Finish & Silver Finish (Low Gear)	Cassette Sprocket Combinations: E 12, 14, 16, 18, 21, 24, 28T. F 14, 16, 18, 21, 24, 28, 32T. G 13, 15, 17, 20, 23, 26, 30T. H 13, 15, 17, 19, 21, 23, 26T. I 13, 14, 15, 17, 19, 21, 23T. J 13, 14, 15, 16, 17, 19, 21T. K 13, 15, 17, 20, 24, 29, 34T. L 12, 13, 14, 15, 17, 19, 21T. M 13, 15, 17, 19, 21, 24, 28T.
Pedal PD-M350	MTB Type Crank Thread: English BC 9/16" x 20T.P.I. Top Clip Locking System: 2-screw 445g. (Pair)	26° Road Clearance Sealed Mechanism Low Profile Design w/Reflector	Body: Resin Plate: Steel•Paint Finish	
Chain CN-HG50 Head Parts HP-R500	See Page 42			

SHIMANO 200GS

SHIMANO
TOTAL
INTEGRATION



SHIMANO 100GS

SHIMANO
TOTAL
INTEGRATION



Shimano 200GS

Model No.	Specifications	Features	Material • Finish	Note																					
Rear Derailleur RD-M200-SGS (Super Long Cage) RD-M200-GS (Long Cage)	6 & 7-speed SIS Compatible Max. Rear Sprocket: 32T. (SGS), 30T. (GS) Min. Rear Sprocket: 12T. (SGS, GS) Front Difference: 20T. (SGS, GS) Total Capacity: 38T. (SGS), 36T. (GS) 323g. (SGS)	Double Servo-Panta Mechanism Centeron Guide Pulley Double Spoke Barrier B-Tension Adjuster Sealed Pivot Axle Sintered Allow Guide Pulley Bushing Chain Retainer	Bracket Body: Light Alloy • Barrel Finish Right Link: Steel • Paint Finish Left Link: Steel • Zinc Plated Plate Body: Resin • Molding	River Type Bracket Available SIS Compatible Detachable Bracket Available																					
Front Derailleur FD-M200-B (Band Type)	Shimano SG Gear Compatible Narrow Type Chain Compatible Capacity: 20T. (Biopace HP) 22T. (Round) Band Diameter: ϕ 28.0—28.6mm. Stroke (CL=47.5): 33.5—54 169g	Rigid Chainguide Trapeze Mechanism with Cable Stopper	Front Band: Steel • Chrome Plated Rear Band: Steel • Zinc Plated Resin • Molding Right Link: Steel • Zinc Plated Resin • Molding Chainguide: Chrome Plated																						
Front Derailleur FD-M201-B (Band Type)	Shimano SG Gear Compatible Narrow Type Chain Compatible Total Capacity: 24T. (Biopace HP) 26T. (Round) Band Diameter: ϕ 28.0—28.6mm. Stroke (CL=47.5): 34—54 170g	Rigid Chainguide Trapeze Mechanism	Front Band: Steel • Paint Finish Rear Band: Steel • Zinc Plated Resin • Molding Right Link: Steel • Zinc Plated Resin • Molding Chainguide: Chrome Plated																						
Rapidfire ST-M200	7-Speed SIS Compatible SLR (Shimano Linear Response) Compatible Lever Clamp Diameter: 22.2mm. 190g (Rear)	Dual Repeat Function Digital Cable Adjust	Bracket: Steel • Paint Finish Lever: Steel • Zinc Plated Resin • Molding	Use with Shimano SIS-SP Cable with Liner Without Brake Lever																					
Shifting Lever SL-M200 (6-Speed) SL-M201 (7-Speed)	6-Speed SIS Compatible (SL-M200) 7-Speed SIS Compatible (SL-M201) Lever Clamp Diameter: 22.2mm. 154g. (SL-M201)	Sealed Mechanism Anatomical Design	Bracket: Steel • Paint Finish Lever: Resin • Molding	Use with Shimano SIS-SP Cable with Liner																					
Cantilever Brake BR-M200 (Standard) BR-M201 (Low Profile Type)	SLR (Shimano Linear Response) Compatible 226g (BR-M201)	Rigid Computer Design Shape Sealed Internal Spring Design Easy Cable Attachment Spring Tension Adjuster (BR-M201)	Steel & Resin	For SLR System use with Rapidfire or SLR Compatible Brake Lever and Shimano Outer Cable with Liner.																					
Brake Lever BL-M200 (4-Finger Type) BL-M201 (3-Finger Type)	SLR (Shimano Linear Response) Compatible Lever Clamp Diameter: 22.2mm. 265g. (BL-M200)	Digital Cable Adjust Stroke Adjust	Bracket: Steel • Resin Covered & Resin Lever: Steel • Zinc Plated Resin Molding																						
Front Chainwheel FC-M200-SG (Shimano SG Gear, Triple MD Type) FC-M201-SG (Shimano SG Gear, Triple Rivet Type) Bottom Bracket Assembly BB-M500	Shimano SG Gear Narrow Type Chain Compatible Crank Length: 170mm Teeth (Biopace): 48T.-38T.-28T. Crank Thread: English BC 9/16" × 20T.P.I. Cup Thread: English BC 1.37 × 24T.P.I., French M35 × 1.0, Italian M36 × 24T.P.I. 756g. (FC-M201-SG) 1,350g. (FC-M200-SG) 339g. (B.B. Set)	Computer Aided Design (Crank) Sealed Mechanism (B.B.)	FC-M201-SG Crank Arm: Light Alloy • Paint Finish Chain Ring: Steel • Paint Finish FC-M200-SG Crank Arm: Steel • Zinc Plated Resin • Molding Chain Ring: Steel • Paint Finish	Spindle: Mark SPL 3PL Width 70 68 Length 121 121																					
Freehub FH-HG20	7-speed SIS Compatible UG/HG Compatible Type Spoke Holes: 36H. Hole PCD: 45 <table border="1" data-bbox="399 1841 778 1942"> <tr> <td>OLD</td> <td>135</td> <td>130</td> <td>126</td> <td>135</td> <td>130</td> <td>126</td> </tr> <tr> <td>Axle Length</td> <td>146</td> <td>141</td> <td>137</td> <td>185</td> <td>180</td> <td>174</td> </tr> <tr> <td>Mounting Type</td> <td colspan="2">Quick Release</td> <td colspan="4">Nut Type</td> </tr> </table> Axle Thread: 10mm 425g. (7-speed w/Quick Release)	OLD	135	130	126	135	130	126	Axle Length	146	141	137	185	180	174	Mounting Type	Quick Release		Nut Type				Uni-Balance System Resin Sealed Mechanism (Choice) One-Piece Forged Hub Body	Light Alloy • Dia-Cut Finish	
OLD	135	130	126	135	130	126																			
Axle Length	146	141	137	185	180	174																			
Mounting Type	Quick Release		Nut Type																						
Multiple Freewheel MF-HG20 (6-Speed)	6-speed SIS Compatible 6-speed HG Use Narrow Type Chain 460g. (Sprocket Y Group)		Steel • Brown Finish	Cassette Sprocket Combinations: X 14, 16, 18, 20, 22, 24T. Y 14, 16, 18, 21, 24, 28T. Z 14, 17, 20, 24, 28, 32T.																					
Pedal PD-M350	MTB Type Crank Thread: English BC 9/16" × 20T.P.I. Top Clip Locking System: 2-screw 445g. (Pair)	26" Road Clearance Sealed Mechanism Low Profile Design w/Reflector	Body: Resin • Paint Plate: Steel • Paint Finish																						
Front Hub HB-RM50-F	See Page 70																								
Cassette Sprockets CS-HG50 (7-Speed) Chain CN-HG50 Head Parts HP-R500	See Page 42																								

Shimano 100GS

Shimano 100GS

Model No.	Specifications	Features	Material • Finish	Note																					
Rear Derailleur RD-M100-GS (Long Cage)	6 & 7-speed SIS Compatible Max. Rear Sprocket: 30T Min. Rear Sprocket: 12T Front difference: 20T Total Capacity: 36T.	Double Servo-Panta Mechanism Centeron Guide Pulley Double Spoke Barrier B-Tension Adjuster Sealed Mechanism Sintered Alloy Guide Pulley Bushing Chain Retainer	Bracket Body: Steel • Zinc Plated Resin • Molding Right Link: Steel • Chrom Plated Left Link: Steel • Zinc Plated Plate Body: Resin • Molding	Rivet Type Bracket Available SIS Compatible Detachable Bracket																					
Front Derailleur FD-M100-B (Band Type)	Shimano SG Gear Compatible Narrow Type Chain Compatible Capacity: 20T. (Biopace HP) 22T. (Round) Band Diameter: ϕ 28.0- ϕ 28.6mm. Stroke (CL=47.5): 34 ~ 54	Ridid Chainguide	Front Band: Steel • Zinc Plated Rear Band: Steel • Zinc Plated Right Link: Steel • Zinc Plated Resin • Molding Chain Guide: Chrome Plated																						
Rapidfire ST-M010	7-speed SIS Compatible SLR (Shimano Linear Response) Compatible Lever Clamp Diameter: 22.2mm.	Dual Repeat Function Light Action Lever Anatomical Design Digital Cable Adjust	Bracket: Steel • Paint Finish Lever: Steel • Zinc Plated Resin • Molding	Use with Shimano SIS Cable With Liner Without Brake Lever																					
Shifting Lever SL-M100 (7-Speed)	7-Speed SIS Compatible Lever Clamp Diameter: 22.2mm.	Anatomical Design	Bracket: Steel • Zinc Plated Lever: Resin • Molding	Use with Shimano SIS Cable With Liner																					
Cantilever Brake BR-M100 (Low Profile Type)	SLR (Shimano Linear Response) Compatible	Rigid Shape Sealed Internal Spring Design Easy Cable Attachment Spring Tension Adjuster	Steel & Resin	For SLR System use with Rapidfire or SLR Compatible Brake Lever and Shimano Outer Cable with Liner.																					
Brake Lever BL-M101 (3-Finger type)	SLR (Shimano Linear Response) Compatible Lever Clamp Diameter: 22.2m.	Digital Cable Adjust Stroke Adjust Anatomical Design	Bracket: Steel • Resin Covered & Resin Lever: Steel • Resin Cored & Resin	Use with Shimano SIS-SP Cable With Liner																					
Front Chainwheel FC-M100-SG (Shimano SG Gear, Triple Rivet Type) Bottom Bracket Assembly BB-M500	Shimano SG Gear Narrow Type Chain Compatible Crank Length: 170mm. Teeth (Biopace): 48T, 38T, 28T. Crank Thread: English BC 9/16" x 20T.P1. Cup Thread: English BC 1.37 x 24T.P1., French M35 x 1.0, Italian M36 x 24T.P1. 339g (B.B. Set)	Sealed Mechanism (B.B.)	Crank Arm: Steel & Resin • Paint Finish Chain Ring: Steel • Paint Finish	Spindle: <table border="1"> <tr> <td>Mark</td> <td>5PL</td> <td>3PL</td> </tr> <tr> <td>Width</td> <td>70</td> <td>68</td> </tr> <tr> <td>Length</td> <td>121</td> <td>121</td> </tr> </table>	Mark	5PL	3PL	Width	70	68	Length	121	121												
Mark	5PL	3PL																							
Width	70	68																							
Length	121	121																							
Freehub FH-HG20	7-speed SIS Compatible UG/HG Compatible Type Spoke Holes: 36H. Hole PCD: 45 <table border="1"> <tr> <td>OLD.</td> <td>135</td> <td>130</td> <td>126</td> <td>135</td> <td>130</td> <td>126</td> </tr> <tr> <td>Axle Length</td> <td>146</td> <td>141</td> <td>137</td> <td>185</td> <td>180</td> <td>174</td> </tr> <tr> <td>Mounting Type</td> <td colspan="3">Quick Release</td> <td colspan="3">Nut Type</td> </tr> </table> Axle Thread: 10mm. 425g. (7-speed w/Quick Release)	OLD.	135	130	126	135	130	126	Axle Length	146	141	137	185	180	174	Mounting Type	Quick Release			Nut Type			Uni-Balance System Resin Sealed Mechanism One-Piece Forged Hub Body	Light Alloy • Dia-Cut Finish	
OLD.	135	130	126	135	130	126																			
Axle Length	146	141	137	185	180	174																			
Mounting Type	Quick Release			Nut Type																					
Front Hub HB-RM50-F	Spoke Holes: 36H., 32H. Hole PCD: 38 <table border="1"> <tr> <td>OLD.</td> <td>100</td> <td>96</td> </tr> <tr> <td>Axle Length</td> <td>108</td> <td>104</td> </tr> <tr> <td>Mounting Type</td> <td colspan="2">Quick Release</td> </tr> </table> Axle Thread: 9mm 228g.	OLD.	100	96	Axle Length	108	104	Mounting Type	Quick Release		Sealed Mechanism (Choice) One-Piece Forged Hub Body	Light Alloy • Dia-Cut Finish													
OLD.	100	96																							
Axle Length	108	104																							
Mounting Type	Quick Release																								
Cassette Sprockets CS-HG50 (7-Speed)	7-speed SIS Compatible 7-speed HG Use Narrow Type Chain 268g. (Sprocket I Group)		Steel • Brown Finish & Silver Finish (Low Gear)	Cassette Sprocket Combinations: <table border="1"> <tr> <td>E</td> <td>12, 14, 16, 18, 21, 24, 28T.</td> </tr> <tr> <td>F</td> <td>14, 16, 18, 21, 24, 28, 32T.</td> </tr> <tr> <td>G</td> <td>13, 15, 17, 20, 23, 26, 30T.</td> </tr> <tr> <td>H</td> <td>13, 15, 17, 19, 21, 23, 26T.</td> </tr> <tr> <td>I</td> <td>13, 14, 15, 17, 19, 21, 23T.</td> </tr> <tr> <td>J</td> <td>13, 14, 15, 16, 17, 19, 21T.</td> </tr> <tr> <td>K</td> <td>13, 15, 17, 20, 24, 29, 34T.</td> </tr> <tr> <td>L</td> <td>12, 13, 14, 15, 17, 19, 21T.</td> </tr> <tr> <td>M</td> <td>13, 15, 17, 19, 21, 24, 28T.</td> </tr> </table>	E	12, 14, 16, 18, 21, 24, 28T.	F	14, 16, 18, 21, 24, 28, 32T.	G	13, 15, 17, 20, 23, 26, 30T.	H	13, 15, 17, 19, 21, 23, 26T.	I	13, 14, 15, 17, 19, 21, 23T.	J	13, 14, 15, 16, 17, 19, 21T.	K	13, 15, 17, 20, 24, 29, 34T.	L	12, 13, 14, 15, 17, 19, 21T.	M	13, 15, 17, 19, 21, 24, 28T.			
E	12, 14, 16, 18, 21, 24, 28T.																								
F	14, 16, 18, 21, 24, 28, 32T.																								
G	13, 15, 17, 20, 23, 26, 30T.																								
H	13, 15, 17, 19, 21, 23, 26T.																								
I	13, 14, 15, 17, 19, 21, 23T.																								
J	13, 14, 15, 16, 17, 19, 21T.																								
K	13, 15, 17, 20, 24, 29, 34T.																								
L	12, 13, 14, 15, 17, 19, 21T.																								
M	13, 15, 17, 19, 21, 24, 28T.																								
Pedal PD-M350	MTB Type Crank Thread: English BC 9/16" x 20T.P1. Top Clip Locking System: 2-screw 445g. (Pair)	26° Road Clearance Sealed Mechanism Low Profile Design w/Reflector	Body: Resin Plate: Steel • Paint Finish																						
Chain CN-HG50 Head Parts HP-R500	See Page 42																								

Tourney

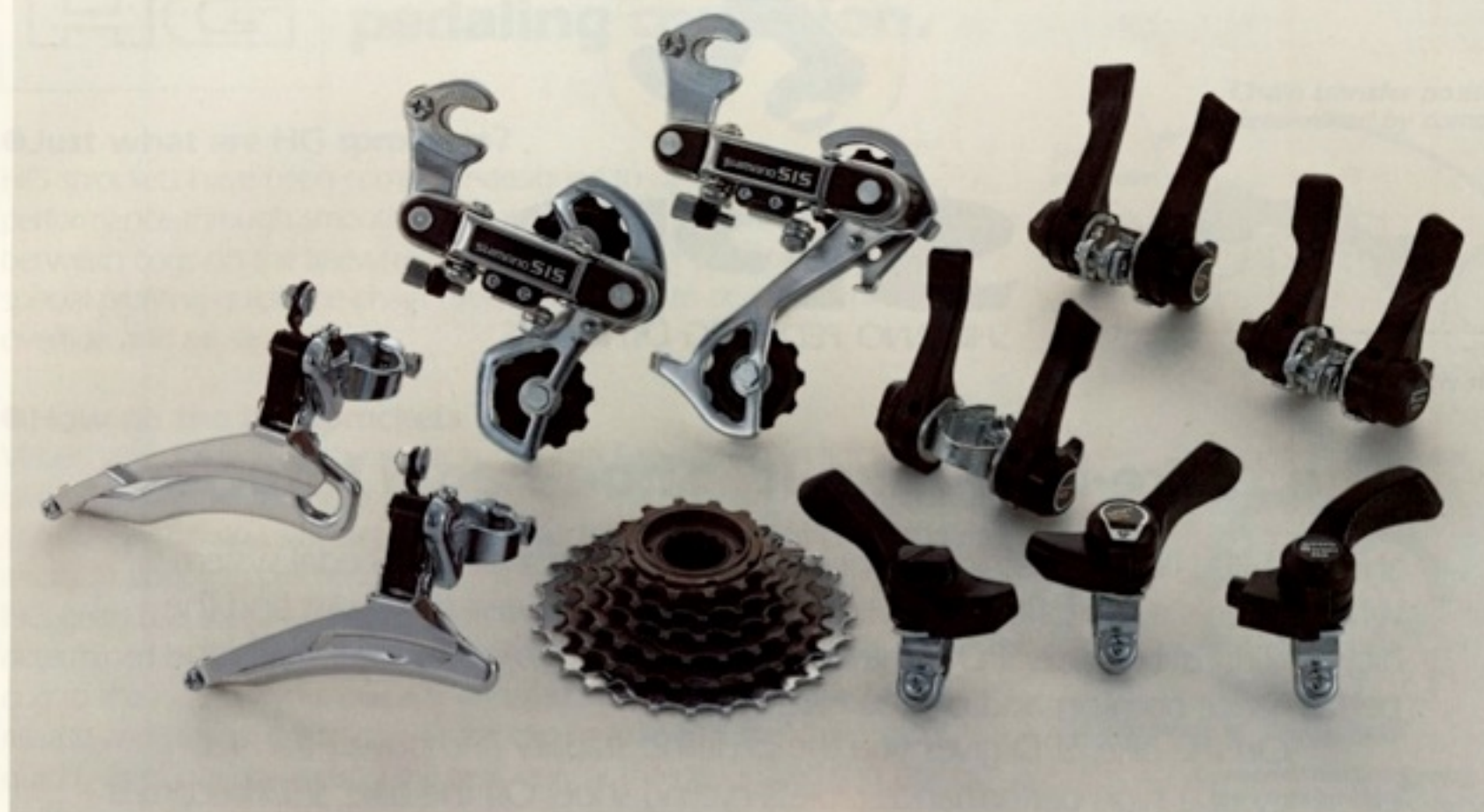

Model No.	Specifications	Features	Material•Finish	Note
Rear Derailleur RD-TY20-GS (Long Cage) RD-TY20-SS (Short Cage)	6-speed SIS Compatible Max. Rear Sprocket: 24-28T. (SS, For Double) 24-32T. (SS, For Single) 28T. (GS) Min. Rear Sprocket: 14T. (GS, SS) Front Difference: 20T. (GS), 13T. (SS) Total Capacity: 34T. (GS), 28T. (SS) 341g. (GS), 317g. (SS)	Double Servo-Pants Mechanism Centeron Guide Pulley Double Spoke Barer Sintered Alloy Guide Pulley Bushing Chain Retainer (GS, Type)	Bracket Body: Steel•Zinc Plated Right Link: Steel•Chrome Plated Left Link: Steel•Zinc Plated Plate Body: Steel•Zinc Plated	Brazed-on Type Available
Front Derailleur FD-TY20-B (Band Type)	Capacity: 14T. Band Diameter: $\phi 28.0\text{mm}$ — $\phi 28.6\text{mm}$. Stroke (w/ $\phi 28.6\text{mm}$ Band): 35—54 Narrow Type Chain Compatible 154g.	Rigid Chainguide Trapease Mechanism With Cable Stopper	Front Band: Steel•Zinc Plated Rear Band: Steel•Zinc Plated Right Link: Steel•Paint Finish Resin•Molding Chainguide: Chrome Plated	
Front Derailleur FD-TY25-B (Band Type)	Capacity: 20T. (Biopace HP) 22T. (Round) Band Diameter: $\phi 28.0\text{mm}$ — $\phi 28.6\text{mm}$. Stroke (CL=47.5): 34—54 Narrow Type Chain Compatible 161g.	Rigid Chainguide Trapease Mechanism With Cable Stopper	Front Band: Steel•Zinc Plated Rear Band: Steel•Zinc Plated Right Link: Steel•Paint Finish Resin•Molding Chainguide: Chrome Plated	
Shifting Lever SL-S452-7 (7-Speed) SL-S452-6 (6-Speed)	Shimano Index System Handle Stem Type Lever Clamp Diameter: 22.2mm. 85g. (7-Speed)	SIS-Friction Mode Switch Light Action Lever (Front) Sealed Mechanism	Lever: Resin	Combination with RD-R552 Use with Shimano SIS-SP Outer Cable with Liner.
Shifting Lever SL-SY20 (6-Speed) SL-SY20-S (Stem Type)	Shimano Index System Down Tube Lever Lever Clamp Diameter: 28.6mm. Handle Stem Type Lever Clamp Diameter: 22.2mm. 91g. (Band Type)	SIS-Friction Mode Switch Light Action Lever (Front) Sealed Mechanism	Lever: Resin	Combination with RD-TY20 Use with Shimano SIS Outer Cable with Liner. Brazed-on & Band Type Available
Shifting Lever SL-MS52-6 (6-Speed) SL-MS52-7 (7-Speed)	Shimano Index System Lever Clamp Diameter: 22.2mm. 120g.	Light Action Lever (Front) Sealed Mechanism Anatomical Design	Bracket: Steel•Zinc Plated Lever: Resin•Molding	Use with Shimano SIS-SP Outer Cable with Liner.
Shifting Lever SL-MY20 (6-Speed)	Shimano Index System Lever Clamp Diameter: 22.2mm. 63g.	Sealed Mechanism Anatomical Design	Bracket: Steel•Zinc Plated Lever: Resin•Molding	Use with Shimano SIS-SP Outer Cable with Liner.
Multiple Freewheel MF-Z012	5 & 6-speed SIS Compatible 451g.		Steel•Brown Finish/Silver Finish	Sprocket Combinations: 6-Speed 14, 16, 18, 20, 22, 24T. 14, 16, 18, 21, 24, 28T. 14, 17, 20, 24, 28, 28T.



SPD
SHIMANO PEDALING DYNAMICS

The “Bike-it or Hike-it” Shoe-Pedal Interface.

Shimano Pedaling Dynamics is a new type of cycling shoe and pedal system which creates a more flexible foot-pedal interface between the cyclist and the bicycle. This is because SPD is the first cycling shoe system that delivers high performance both on and off the bike.

On the bike, SPD gives you the pedaling stability and power transfer efficiency of a high performance clipless cycling shoe. Off the bike, SPD becomes a comfortable sure-footed hiking shoe that gives you excellent traction on any surface thanks to its recessed cleat design.

SPD realizes the best of both worlds—high performance clipless pedaling with the ability to walk anywhere safely and comfortably.



A flexible application shoe-pedal interface with special benefits for the off-road cyclist.

●Just what is Shimano Pedaling Dynamics?

Shimano Pedaling Dynamics (SPD) is a new type of cycling footwear which really does two jobs. It's a high-performance clipless pedaling system, yet the SPD shoe lets you walk securely and comfortably off of the bike, on any surface, because there's no cleat interference with the ground.

●How does SPD work?

The SPD shoe (SH-M100) features a unique cleat which is recessed into the sole. The cleat locks into the SPD pedal (PD-M737) to form a clipless pedaling interface with a highly efficient pedaling action. The SPD shoe also features an outer sole with an aggressive tread pattern that makes it an excellent hiking shoe. And because the cleat is recessed into the outer sole, it doesn't interfere with walking. You can get off the bike and walk securely and comfortably on any type of surface.

Thanks to a unique shoe-pedal binding system, all you have to do is step onto the pedal to engage the cleat locking mechanism. Release is through a simple twist-out movement. The open architecture design prevents mud buildup and the cleat binding mechanism is incorporated on both sides of the pedal for easy entry without pedal flipping.

●What are the benefits for the rider?

The main benefit to the rider is that SPD provides more flexibility without sacrificing performance. On the bike, you get the same power transfer efficiency as if you were wearing a clipless racing shoe. Yet off the bike you can walk safely and comfortably just like you would wearing hiking shoes.

This is a real advantage in off-road riding, and especially off-road competition, when you often have to get off the bike to take on really rugged terrain on foot. But SPD also gives you the freedom to get off the bike to rest, explore, or walk a bit. While SPD is the best shoe-pedal system for off-road competition, it's also great for touring and sport cycling.

SPD gives you competition-level clipless pedaling efficiency on the bike. SPD also gives you the freedom to get off the bike and walk comfortably and safely. This flexibility is the real advantage of SPD.



Twist-out



Recessed cleat

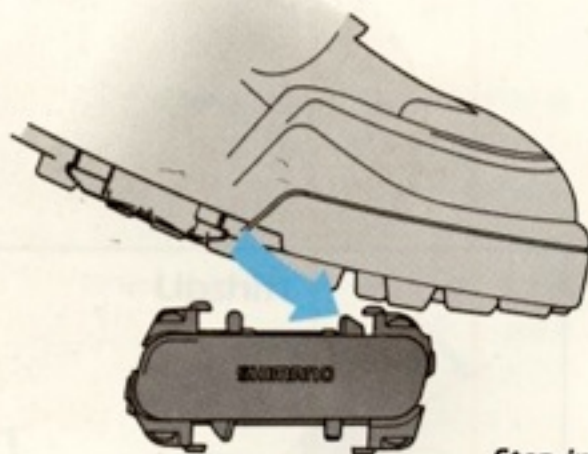

Step-in

SHIMANO

CYCLING FOOTWEAR

Shimano Cycling Shoes... Aiming at more efficient, and comfortable, pedaling performance.

Now you can get the Shimano biomechanical advantage in a full line of high-performance cycling shoes. On the pavement or in the dirt, Shimano cycling shoes incorporate advanced, performance specific features that give you enhanced power transfer efficiency with greater foot comfort than ever before, even after hours in the saddle. Shimano cycling footwear makes a more efficient power interface between rider and bicycle.



Shoe
SH-M100
Pedal: PD-M737



Shoe
SH-R100
Pedal: PD-6401



Shoe
SH-T100
Pedal: PD-1056

SH-M100

Rugged, durable brushed split leather and nylon reinforced toebox protects foot.

Extra-long adjustable Velcro straps assure a snug, comfortable fit that won't loosen during riding or walking.

Reflectorized heel and side panel enhance nighttime visibility.

Cambrelle and EVA sockliner wicks away moisture. The interior of the shoe is completely lined with Cambrelle.

Soft ankle padding provides a comfortable fit. Synthetic collar liner provides added durability.

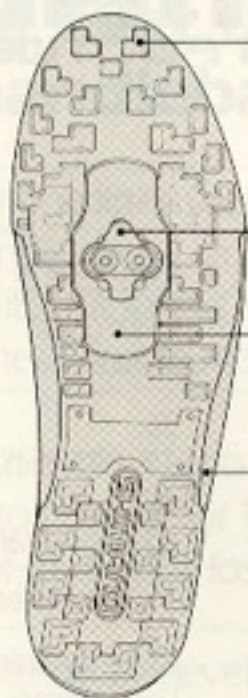
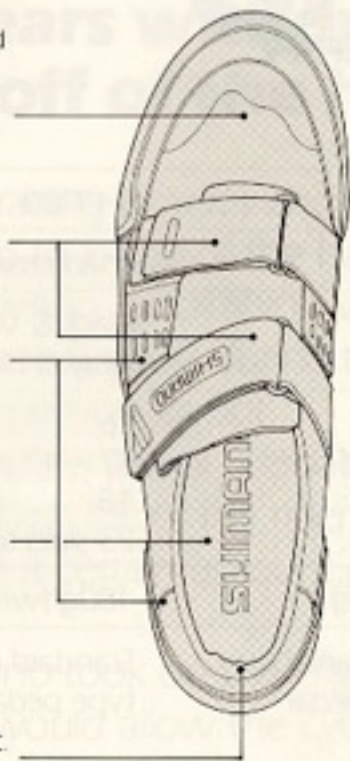

High-traction rubber outsole for sure-footed hiking off-road.

"Recessed design" cleat allows both clipless pedaling and comfortable walking.

Glass fiber reinforced nylon midsole protects feet and enhances pedaling efficiency.

EVA heel for shock absorption and foot protection.



SH-R100

Ventilation slots let cooling air in, keep foreign matter out.

3-point friction pads for non-slip walking.

Shimano/Look cleat mounts offer a 7mm forward adjustment range.

Rigid carbon plate insert improves power transfer efficiency.

Hard, super-thin 4mm glass fiber outsole at pedal contact area.

Rubber heel pad for non-slip walking.

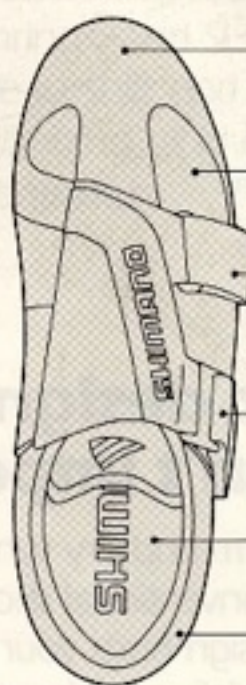
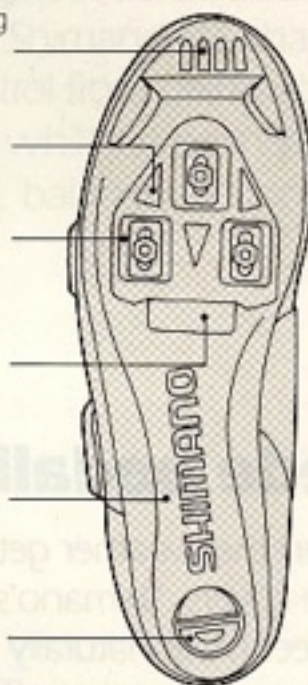

Full grain, pearlized leather upper repels water and requires no "break in."

Non-stretch, breathable, ballistic nylon mesh upper.

Secure, oversize Velcro straps assure a snug and efficient fit for any foot shape.

Dual-layer sockliner of breathable Cambrelle and EVA enhances fit and comfort.

Reflectorized heel counter for greater nighttime visibility.

SH-T100

Breathable, non-stretch, scuff-resistant nylon upper.

Double Velcro straps won't loosen during hard pedaling.

"Free-instep" design saves weight and assures a snug and comfortable fit.

Cambrelle and EVA sockliner helps keep feet dry and comfortable.

Soft, terry-cloth heel counter wicks away moisture and improves comfort.

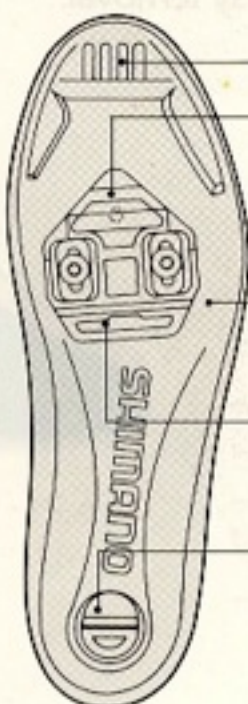
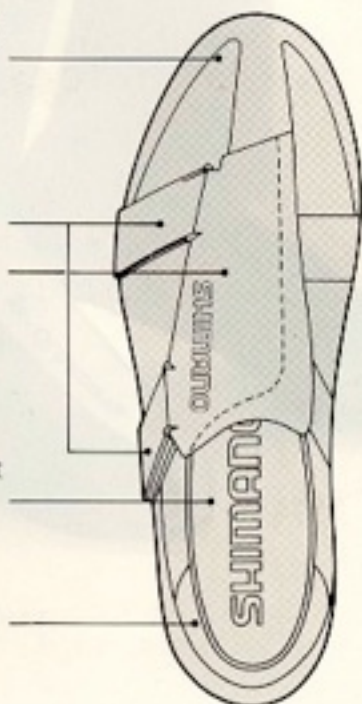

Ventilation slots keep your feet cool.

Shoe comes with standard cleat for use with toe clips and straps. (Cleat drilling also compatible with clipless cleats.)

Hard, super-thin 4mm glass fiber outsole at pedal contact area.

Friction pad reduces slipping and protects the cleat.

Rubber heel pad for non-slip walking.

SHIMANO

CYCLING FOOTWEAR

Specifications

Model	SH-M100	SH-R100	SH-T100
Application	Off-road/Competition	Road racing	Road racing/Sport cycling
Color	Gray	Dark gray/ White	Black & White/ Gray & Blue
Available sizes	36, 37—47 in half sizes 48 23 sizes total	36, 37—47 in half sizes 48 23 sizes total	36, 37—47 in half sizes 48 23 sizes total
Weight	680g (w/o cleats)	530g (w/cleats)	480g (w/cleats)
Type of cleat included with shoes	Special SPD cleat available with PD-M737 pedals. Cleats are not included with shoes.	Cleat for Shimano/Look clipless pedal system.	Standard cleat for quill-type pedals with toeclips.

Anatomic design that doesn't impede pedaling

Keep your feet warm and dry when the weather gets cold and wet. Unlike conventional shoe covers, Shimano's two-piece anatomic design hugs your feet more naturally and doesn't impede pedaling. Nylon-coated neoprene effectively shuts out cold and moisture. Heavy duty zipper and Velcro fastening system provides for a snug fit and easy removal. You can even adjust them while riding.

Shoe Covers

SH-CV10

Application	Road-racing/Sport cycling	
Color	Gray & Dark gray	
Available Sizes	Shoe cover size	Shoe size
	S	36 ~ 38.5
	M	39 ~ 41.5
	L	42 ~ 44.5
	XL	45 ~ 48



SMALL PARTS & TOOLS







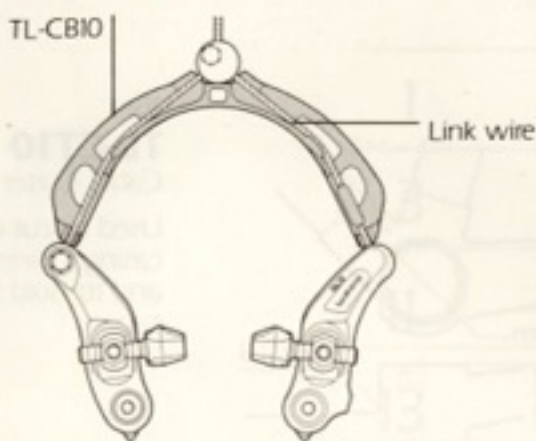

Tool
TL-CB10
 Pro-Set Tool for Cantilever Brakes

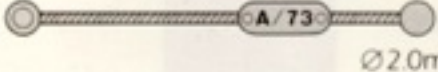
This tool is for the correct and quick installation of the cantilever brake.

■ Combinations

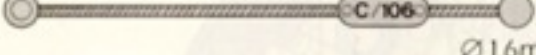
The tool and link wire are different for each cantilever brake model. Combine the parts correctly.

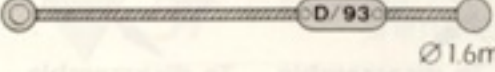

Type	Tool (TL-CB10)	Link Wire	Cantilever Brake
A	Color: Blue  A/73	 A/73 Ø2.0mm	BR-M734 Front BR-M650 Front BR-M201 BR-M100 BR-M352
B	Color: Violet  B/82	 B/82 Ø2.0mm	BR-M734 Rear BR-M650 Rear
C	Color: Yellow  C/106	 C/106 Ø1.6mm	BR-M201 BR-M100
D	Color: Orange  D/93	 D/93 Ø1.6mm	BR-M201 BR-M100
E	Color: Green  E/84	 E/84 Ø1.6mm	BR-M352

Small Parts
SM-CS50
 Outer Stopper
 for SL-BS50

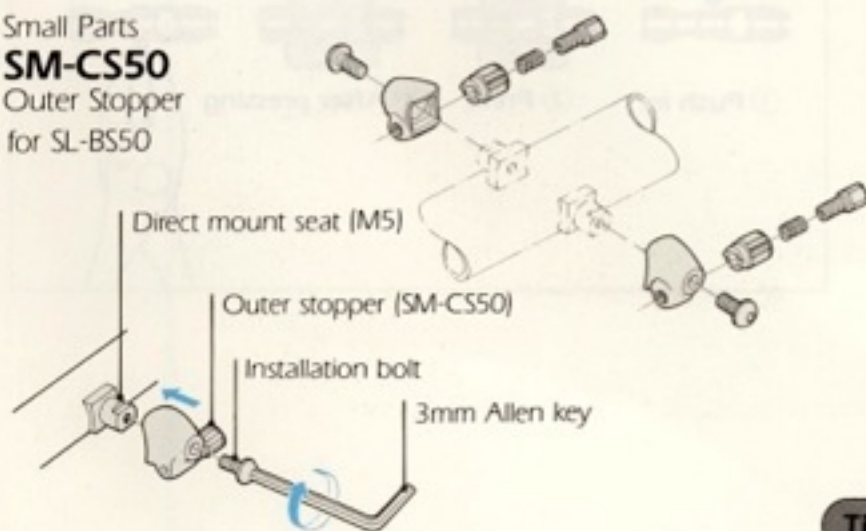

Small Parts
SM-ST74
 Outer Stopper for ST-7400

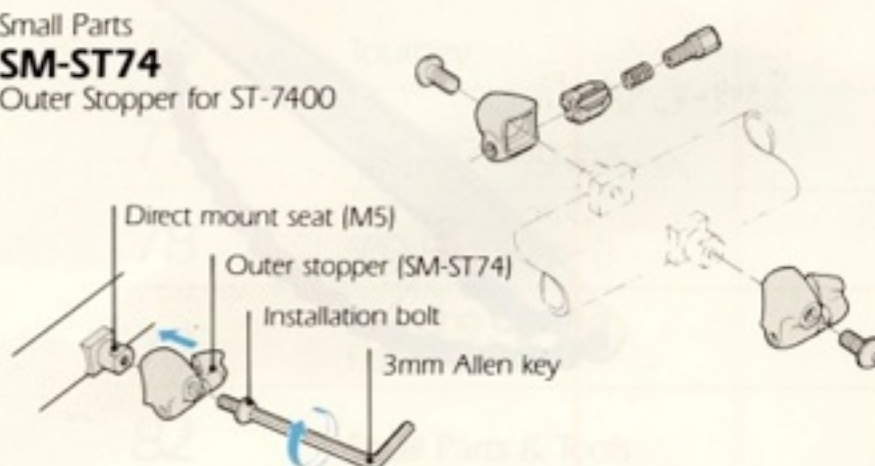

Tightening torque: 15 - 20 kgfcm (13 - 18 in.lbs.)

SMALL PARTS & TOOLS

Small Parts
SM-SP55/SM-MT55
 Bottom Bracket Cable Guide

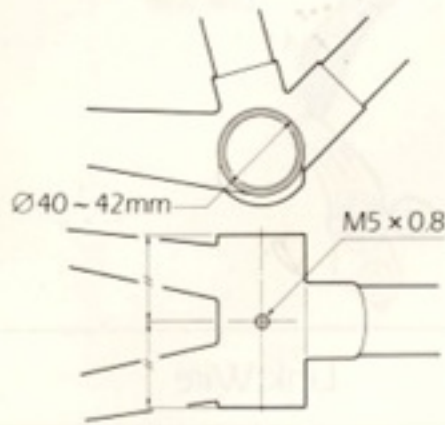

Tool
TL-CT10
 Cable Cutter

Used to cut outer casings, inner cables, and to hold the cable cap.

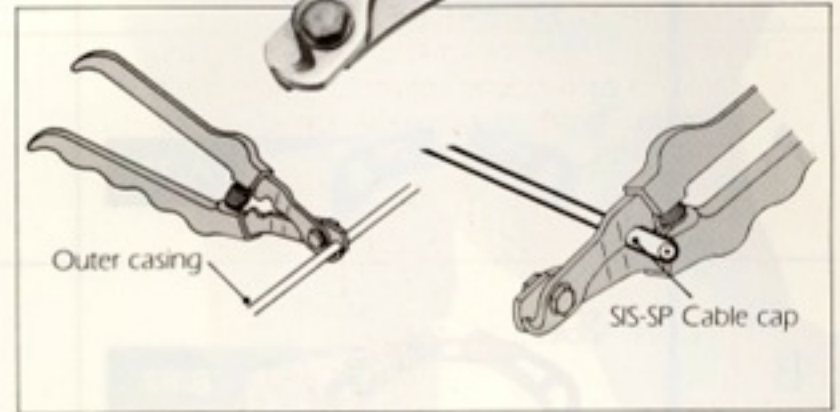

Tool
TL-HG15
 Lock Ring Tool for HG Sprockets



- For installation of the HG sprocket, use the special tool (TL-HG15) to tighten the lock ring.

Tightening torque:
 300 ~ 500 kgfcm
 (260 ~ 430 in.lbs.)

- To replace the HG sprocket, use the special tool (TL-HG15) and TL-SR20 to remove the lock ring.

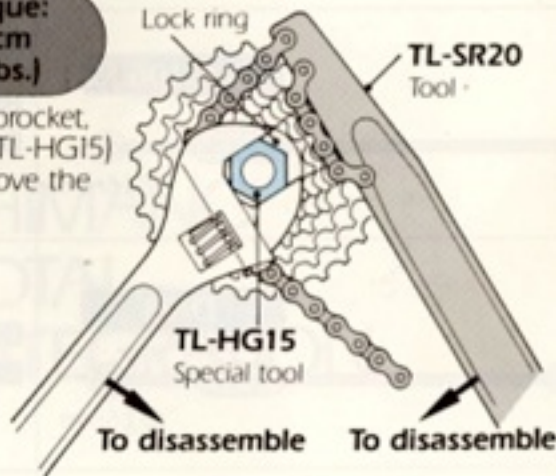

Tool
TL-CN21
 Chain Cutter
 HG chain must use this chain cutter.



Reinforced Special Pin for HG compatible chain



Tool
TL-SR20
 Rear Sprocket Removal Tool



How to use the reinforced special pin

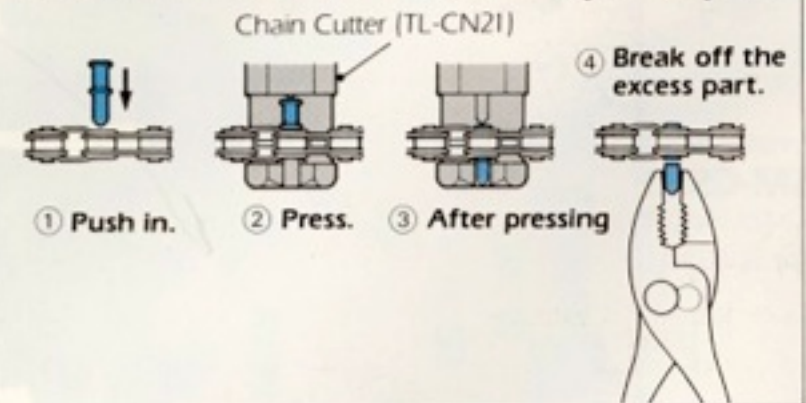

Tool

TL-PD40

Pedal Axle Unit Removal Tool
for PD-1056, PD-1055, PD-A550
and PD-M737



Attach the special tool (TL-PD40) to the locking sleeve, and then use the wrench (TL-FC30) to remove. The direction to turn the locking sleeve (to tighten) is indicated on each locking sleeve. To remove the axle unit, turn the locking sleeve in the opposite direction.

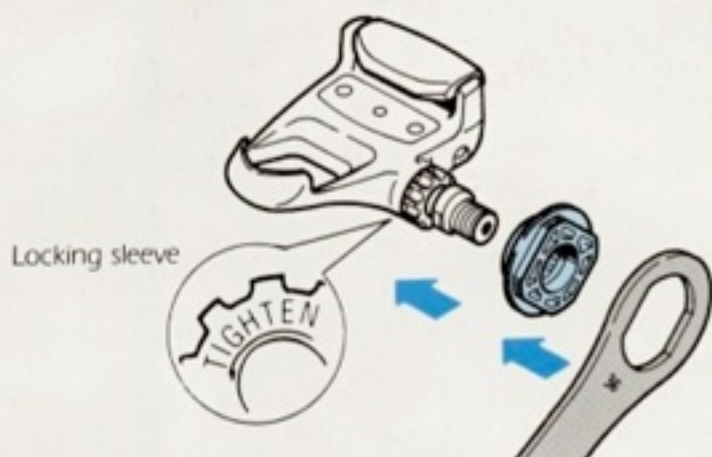

Tool

TL-FC30

Three Spanners Set
for front chairwheel, head parts
and pedal



Tool

TL-FC10

Cotterless Crank Extractor



Tool

TL-RD10

Rear Dropout Centering and Rear Hanger Alignment Tool

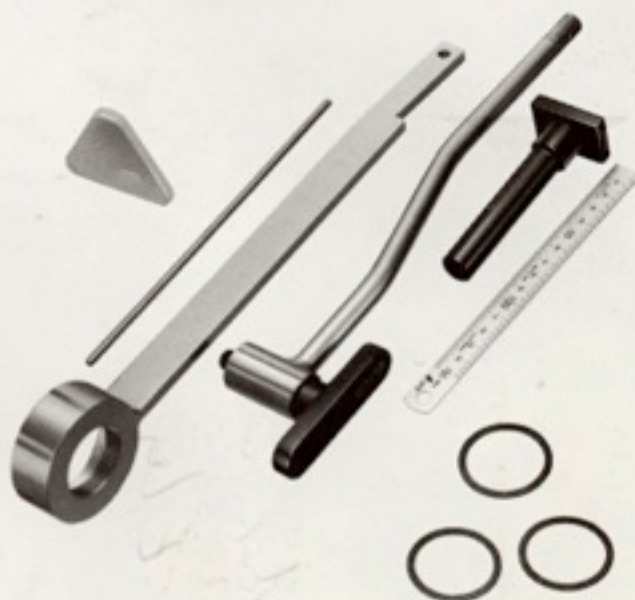

This tool is used to adjust the parallelism of the rear derailleur mount and hub axle lock of the rear dropout. A gauge is provided for easy use and quick adjustments.

NOTE

When using this tool, please be sure to have a small flanged rear hub without a rim.

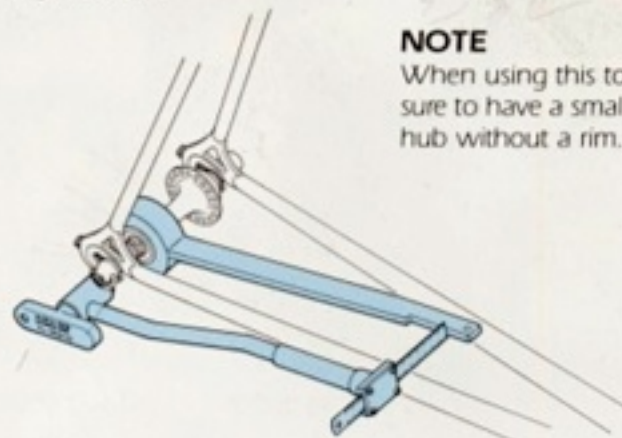

PAUL LANGE & CO.

Nordbahnhofstraße 31 - Postfach 10 29 28 - D-7000 Stuttgart 10 - West Germany
Tel. 07 11-25880

ETS BERTIN

Rue Georges Clemenceau - BP 45 - F-62052 St-Laurent-Blangy Cédex - France
Tel. 21-73.25.25

M.I.C. MILAN INTERNATIONAL COMMERCE

Via Piscane 3 - I-20027 Rescaldina (MI) - Italy - Tel. 03 31-464626

CILO S.A.

Ch. du Raffort 1 - Case Postale 89 - CH-1032 Romanel - Switzerland
Tel. 021-361371

CITRA INTERNATIONAL B.V.

Industrieweg 24 - NL-8071 CT Nunspeet - Postbus 180 - NL-8070 AD Nunspeet
Holland - Tel. 03412-51884

MADISON CYCLES PLC

4 Horseshoe Close - London NW2 7JJ - U.K. - Tel. 081-4525401

THÄLINGER GMBH

Bainhofsstraße 46 - Postfach 182 - A-4600 Wels - Austria - Tel. 07242-4970

EVERTON TRADING A/S

Postbox 609 - Torupvej 63 - 65 - DK-520 Odense NV - Denmark
Tel. 066-164411

HALLMAN SPORTS

Box 2055 - Stalgatan 8 - S-750 02 Uppsala - Sweden - Tel. 01811485

SJÖSTRAND BIKE COMPANY

Bullgatan 17 - S-442 40 Kungälv - Sweden - Tel. 0303-94090

HELKAMA BICA OY

Helkama Pyörä - SF-02960 Hanko - Finland - Tel. 011-86471

ØGLAEND DBS A.S.

P.O. Box 385 - N-4301 Sandnes - Norway - Tel. 04-675800

CASA MASFERRER S.A.

Calle Barcelona, 98 - Apartado de Correos, 89 - E-Granollers (Barcelona)
Spain - Tel. 03-8708051

MACARIO LLORENTE S.A.

Capitán Blanco Argibay, 137 - E-28029 Madrid - Spain - Tel. 01-3157600

VELIMSA

Panamá 3 - E-01012 Vitoria - Spain - Tel. 045-279133

IBA, LDA

Avenida Columbano - Bardalo Pinheiro, 59 - P-1000 Lisboa - Portugal
Tel. 01-7261698

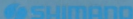
**SHIMANO (EUROPA) GmbH.**

Kleinholzen 1-3, 4030 Hilsen, West Germany Tel. 02103-5005-0

SHIMANO AMERICAN CORPORATION

One Shimano Drive, P.O. Box 19615, Irvine, California U.S.A. 92713-9615 Tel. (714) 951-5003

SHIMANO (SINGAPORE) PTE. LTD.

No. 20, Bencoolen Street, Joojong Town, Singapore 2262 Tel. 2654777

SHIMANO INDUSTRIAL CO., LTD.

3-77 Ohtsucho, Sakai, Osaka, Japan Tel. 07223-233243