

Force 40 Plus™ Braking System Instructions

The Cannondale Force 40 Plus braking system re-routes brake cables to increase the power of standard cantilever brakes by 40%. Give yourself ample time on easy terrain to become accustomed to this increased power and the “feel” of the Force 40 Plus brakes before doing any aggressive riding. In order to achieve maximum performance and efficiency, it is essential that the Force 40 Plus system be set up and adjusted properly as detailed below.

Warning: Failure to follow the instructions below could adversely affect the performance of your brakes, possibly resulting in a crash and serious injury. If you are at all unsure about your ability to properly set-up and/or adjust your Force 40 Plus brakes, bring your

bicycle to your local authorized Cannondale retailer. (For the name and location of your nearest authorized Cannondale retailer, call our Customer Service Department at 1 800 BIKE USA. In Pennsylvania or outside the U.S., call 1-814/623-2626.)

Please note: Part names appearing in all capital letters (e.g. CAM ASSEMBLY) are referenced in the accompanying drawings.

Also, all references to left and right assume that the reader is facing the front or rear brake assembly as each step is performed. References to left and right are not based upon the relative orientation of the brake parts to a rider seated on the bicycle.

1. Set up the brake pads as with any other braking system. Make sure that the pads will contact only the rim, and not the tire or the spokes, when the brakes are applied. Also, as with other braking systems, be sure that there is no more than 2 mm of pad toe-in.
2. Set the brake arm retractor spring higher on the left brake arm than on the right. If the bicycle is equipped with CODA brakes, apply 1/4 turn more spring tension to the left brake arm. With Shimano brake arms, use the non-SLR setting for both arms. The left brake arm should be set with the highest possible spring tension (with the spring post inserted

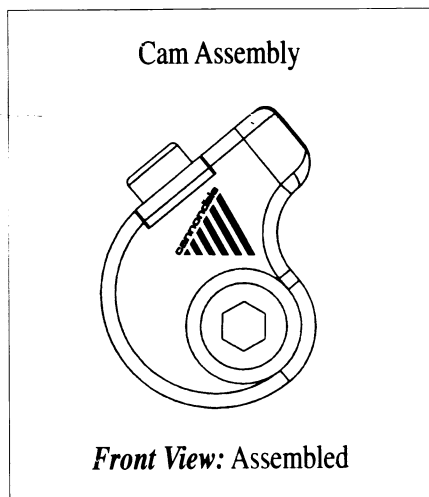

Front View: Assembled

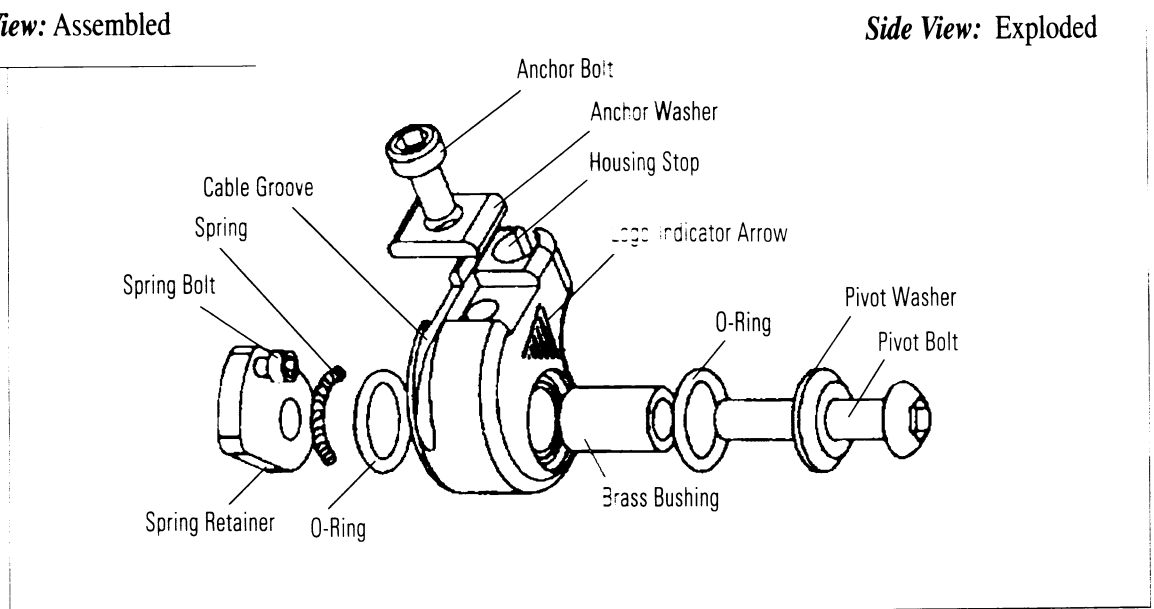

Side View: Exploded

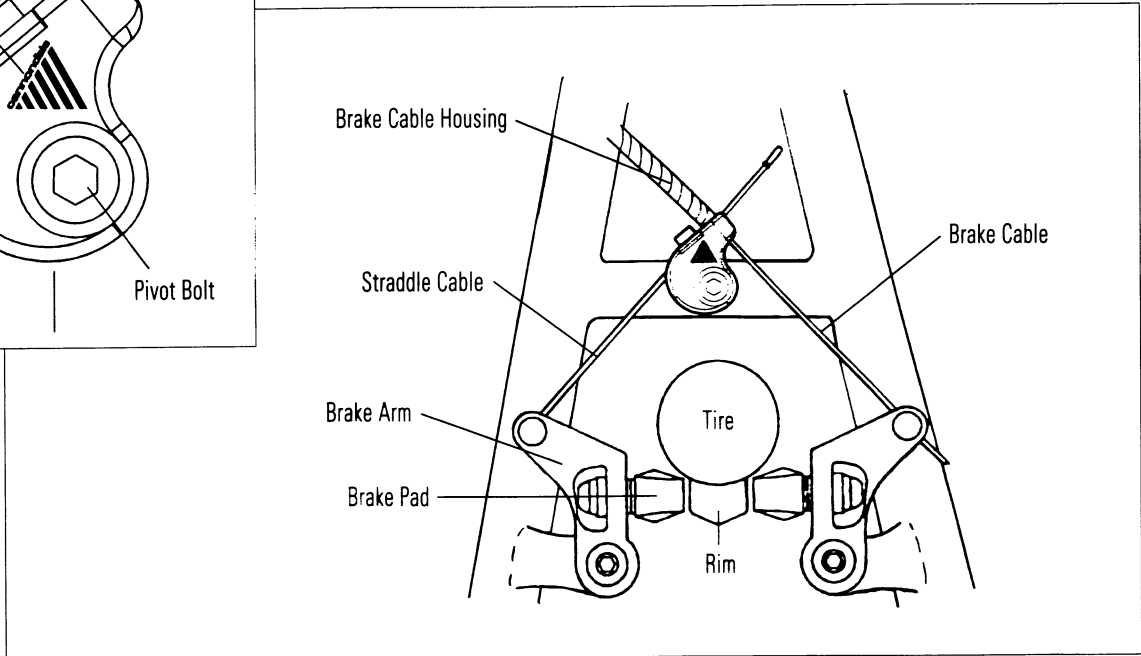
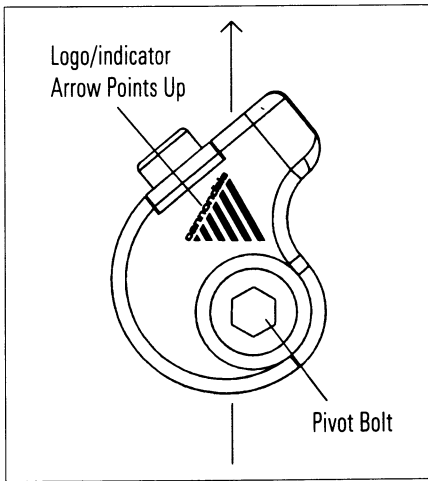

into the highest hole in the brake boss on the seat stay). The right brake arm should be set with the lowest possible spring tension (with the spring post inserted into the lowest hole in the brake boss on the seat stay).

3. Align the CAM ASSEMBLY so the LOGO/INDICATOR arrow points straight upward, and tighten the pivot bolt. Be sure that the CAM ASSEMBLY returns to its "positive stop position" by rotating it clockwise with your fingers and then releasing it. The spring in the CAM ASSEMBLY

should cause the CAM ASSEMBLY to return to its original position (with the LOGO/INDICATOR ARROW pointing straight upward). It should not be able to pivot counter-clockwise beyond this point.

4. Anchor the end of the STRADDLE CABLE at the left brake arm in the standard fashion. Thread the STRADDLE CABLE from the left brake arm through the CABLE GROOVE on the top surface of the CAM ASSEMBLY. (You may first need to loosen the ANCHOR BOLT and ANCHOR WASHER before threading the cable through the CABLE GROOVE.)

Position of cam assembly while braking

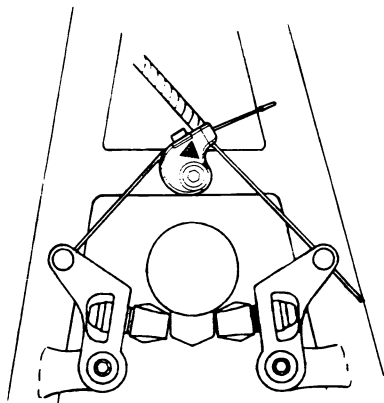

Original position of cam assembly

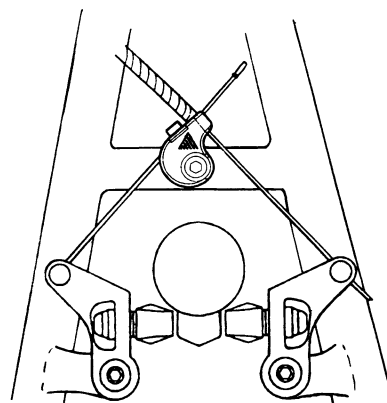

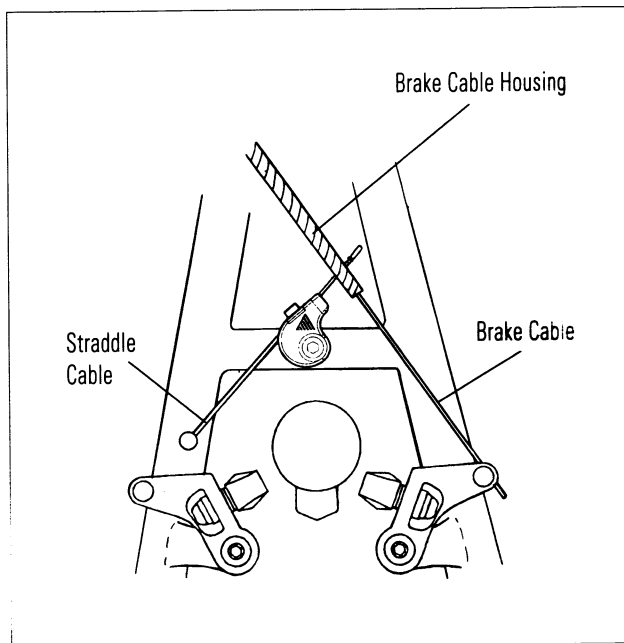

5. While holding the left brake arm against the wheel rim with your left hand, firmly pull the upper end of the STRADDLE CABLE with your right hand. (The STRADDLE CABLE should slide through the loosened ANCHOR WASHER when you pull on it. The CAM ASSEMBLY should not rotate clockwise. If the CAM ASSEMBLY rotates clockwise while you pull on the STRADDLE CABLE, loosen the ANCHOR BOLT further.)
6. With your left hand, slowly lessen the pressure holding the left brake arm against the wheel rim. As the left brake arm pivots away from the rim, it should pull a small length of STRADDLE CABLE through the CABLE GROOVE on the CAM ASSEMBLY. (Again, the CAM ASSEMBLY should remain in the "positive stop position" throughout this step.) Tighten the ANCHOR BOLT to secure the STRADDLE CABLE beneath the ANCHOR WASHER.
7. Check to see if the lower end of the straddle cable can be removed from the left brake arm when the left brake pad is held firmly against the wheel rim by hand. If the STRADDLE CABLE can just be released by hand, proceed to step 8. If the STRADDLE CABLE cannot be released from the left brake arm, loosen the ANCHOR BOLT and repeat step 6 above. After re-tightening the ANCHOR BOLT, again check to see if the STRADDLE CABLE can be removed from the left brake arm. Repeat as necessary, until the lower end of the STRADDLE CABLE can just be released from the left brake arm.
8. Insert the BRAKE CABLE HOUSING and cable from the brake lever into the HOUSING STOP on the CAM

ASSEMBLY. (The cable should be inserted through the slot in the side of the HOUSING STOP.) With the right brake arm held in contact with the wheel rim, anchor the brake cable directly to the right brake arm. While anchoring the cable in the right brake arm, make sure that the CAM ASSEMBLY remains in its "positive stop position" (see step 3).

Note: Adjustments made to the brake pad/rim clearance with the brake lever's barrel adjuster will only affect the right brake arm.

9. Test the brakes by squeezing the brake lever. As the brake lever is released, the right brake arm should pull away from the rim to provide adequate rim/pad clearance. If the rim/pad clearance is inadequate, adjust the clearance by loosening the cable anchor bolt on the brake arm and repositioning the cable within the brake arm.
10. After testing the brakes above, also check to ensure that the CAM ASSEMBLY returns to its original "positive stop position" (with the LOGO/INDICATOR ARROW pointing straight upward) after braking. If the CAM ASSEMBLY fails to rotate back completely to the "positive stop position" an error has been made in setting up the brakes. Repeat steps 3 and 4, being sure to apply greater spring tension to the left brake arm and less spring tension to the right brake arm.

To remove the wheel: Remove the end of the straddle cable from the left brake arm, as with normal cantilever brakes. Rotate the CAM ASSEMBLY clockwise, then remove the cable housing and cable from the HOUSING STOP on the CAM ASSEMBLY. The brake arms will now retract enough to allow the removal of the wheel. **Note:** Be sure to replace the cable and housing in the HOUSING STOP on the CAM ASSEMBLY after re-inserting the wheel, but before re-connecting the end of the straddle cable with the left brake arm.

Troubleshooting

1. If the brakes are not centering properly, try one or more of the following suggestions:
 - Make sure the CAM ASSEMBLY returns to the "positive stop position" when the brake lever is released. If it does not, increase the spring tension on the left arm and decrease the spring tension on the right arm.
 - With Shimano and other "low profile" brake arms, set the arm in a low profile or vertical position. (The closer the arms are positioned to the wheel,

the more spring tension is produced. This increased spring tension will help center the brakes.)

- Substitute 5 mm cable housing for oversized housing.
 - Disconnect the brake arms from the CAM ASSEMBLY and rotate the CAM ASSEMBLY by hand. If it feels sluggish or if there is excessive drag, the CAM ASSEMBLY may be defective. If you suspect that the CAM ASSEMBLY is defective, have your bicycle's braking system inspected by your local authorized Cannondale retailer.
2. If the straddle cable is slipping in the CAM ASSEMBLY, remove the ANCHOR BOLT and apply grease to

the threads at the end of the bolt. Re-install the ANCHOR BOLT and tighten securely.

3. If the brakes have a soft, mushy feel:
- Check for excessive brake pad toe-in and correct as necessary.
 - Check for excessive pad retraction and correct as necessary.

Note: Some brake levers have an inherently mushy feel, and no amount of adjusting the Force 40 Plus braking system will alleviate the problem. In these cases, replacing the brake levers with Shimano or Ritchey Logic levers is the best option.

cannondale[®]

©1992 Cannondale Corporation, Georgetown, CT. 06829