

# 2011 BICYCLES



**cannondale**

# 2011

## FORTY YEARS

*This year we celebrate our 40th anniversary. If you listen to conventional wisdom, 40 is the time to stick to the path, get comfortable in your role in life and start thinking about your retirement plan. Yeah, right.*

*If we'd listened to convention we'd never have Lefty or On or SuperSix or HeadShok or BB30, or in the very beginning, oversized aluminum, for that matter, or any other of the many breakthrough bikes and technologies we've developed.*

*That said, we never settle for what we've done, never rest on our laurels, always strive to make bikes for you that have tangible benefits and quantum improvements. Bikes that are lighter, stronger, better. That simply put, just improve the ride. It's a process that never stops. A quest that never ends.*

*40 years ago someone had a simple idea: to make cycling products that were better. While much at Cannondale has changed since then, our goals remain the same. Improve the Ride. Make it Faster. Make it Better.*

*Get ready for Better.*



**Bikes Belong**  
COALITION



peopleforbikes.org

1997  
2003  
2004  
2007  
2010

# MAGLIA ROSA



# 2011

## GET READY FOR BETTER.

*BETTER SUSPENSION. BETTER HANDLING. BETTER WEIGHT.  
BETTER EFFICIENCY. BETTER STIFFNESS. BETTER COMFORT.  
BETTER STYLE. BETTER PERFORMANCE. BETTER RIDE.  
NO MATTER WHAT ASPECT OF CYCLING YOU VALUE MOST,  
WE'VE FIGURED OUT A WAY TO MAKE IT BETTER.*

### **1** *OVERMOUNTAIN BIKES*

**OverMountain** does what "all-mountain" can't. For anyone who's ever wished they could ride their XC bike to the top of the hill and their long-travel bike back down, we present the **OverMountain** bikes; a family of dual-travel, dual-personality superbikes so versatile and so capable that they needed a category all their own.

### **2** *SCALPEL*

Simply put, the all-new **Scalpel** is the lightest, stiffest, fastest, winningest dual-suspension XC race bike in the world. Featuring the legendary **Zero Pivot** suspension system, **BallisTec** carbon construction and a full complement of System Integrated components, the **Scalpel** is the ultimate race weapon for World Cup warriors.

### **3** *BAD BOY SOLO*

If you're looking for the baddest, blackest bike on the block, look no further. With its stealthy tube shapes, black on black color scheme and head-turning **HeadShok Solo** single-legged suspension fork, the new **Bad Boy Solo** is a rolling understatement of style and attitude.

### **4** *SUPERSIX*

Whether carrying **Ivan Basso** to victory in the 2010 Giro d'Italia, or **Peter Sagan** to stage victories and the Best Young Rider classification in the Tour of California, the **SuperSix** is living up to its reputation as one of the best road racing machines on the planet. Phenomenal stiffness-to-weight, surprising comfort and Cannondale's famous lively, communicative ride-feel create a bike that feels like an extension of your body. Don't settle for the dead, wooden feel of other carbon bikes. Connect. With **SuperSix**.

### **5** *CAAD10*

How could we improve on the finest aluminum road frame in the world, the **CAAD9**? Simple. We completely redesigned it, making it even lighter, stiffer, and smoother. At a mere 1150 grams, with incredible power transfer and the bump eating smoothness of the **SAVE** micro-suspension system, the **CAAD10** is going to give some of our competitors fits trying to explain why someone would want to pay so much more for their heavier, harsher carbon race frames.



For more information check out our website at [www.cannondale.com](http://www.cannondale.com)

# FIND YOUR PERFECT RIDE



## MOUNTAIN

### OVERMOUNTAIN 8

Dual Travel Aggressive Trail

CLAYMORE 180/110 MM TRAVEL

JEKYLL 150/90 MM TRAVEL

### FULL SUSPENSION 22

Marathon Trail / XC Race

RZ ONE TWENTY 120 MM TRAVEL

SCALPEL 80 MM TRAVEL

### HARDTAIL 30

XC Race / Trail

FLASH CARBON RACE CARBON

FLASH RACE ALLOY

TRAIL SL / TRAIL TRAIL RIDE

### 29'ER 40

Big Wheel XC Race / Trail

FLASH CARBON 29'ER RACE CARBON

FLASH 29'ER RACE ALLOY

TRAIL SL 29'ER TRAIL RIDE



## ROAD

### ELITE ROAD 48

Race-Bred Road

SUPERSIX RACE CARBON

CAAD10 RACE ALLOY

CAAD8 RACE-INSPIRED ALLOY

### PERFORMANCE ROAD 60

High Performance Comfort Road

SYNAPSE CARBON COMFORT RACE

SYNAPSE ALLOY COMFORT ROAD

### TRIATHLON / TIME TRIAL 66

All Distance Tri / TT

SLICE RACE CARBON

### CYCLOCROSS 70

Cross Race / Sport Commuting

SUPERX RACE CARBON

CAADX RACE-INSPIRED ALLOY



# RECREATION / URBAN

## RECREATION 78 *Fitness, Fun, Utility*

- QUICK *FAST FLAT-BAR FITNESS*
- QUICK CX *RUGGED FLAT-BAR VERSATILITY*
- ADVENTURE *PLUSH UPRIGHT COMFORT*
- TANDEM *DOUBLE FUN*

## URBAN 86 *Stylish City Mobility*

- BAD BOY *SPEED AND ATTITUDE*
- HOOLIGAN *COMPACT CITY FUN*



# WOMEN'S

## OVERMOUNTAIN W4 *Dual Travel Aggressive Trail*

- SCARLET *150/90 MM TRAVEL*

## FULL SUSPENSION W6 *Aggressive Trail or Marathon*

- LEXI *120 MM TRAVEL*

## HARDTAIL W9 *XC Race or Trail*

- FLASH *RACE ALLOY*
- TRAIL SL / TRAIL *TRAIL RIDE*

## ELITE ROAD W12 *Race-Bred Road*

- SUPERSIX *RACE CARBON*
- CAAD10 *RACE ALLOY*

## TRIATHLON / TIME TRIAL W18 *All Distance Tri / TT*

- SLICE *ALL DISTANCE TRI / TT*

## PERFORMANCE ROAD W20 *High Performance Comfort Road*

- SYNAPSE CARBON *COMFORT RACE*
- SYNAPSE ALLOY *COMFORT ROAD*

## RECREATION W26 *Fitness, Fun, Utility*

- QUICK *FAST FLAT-BAR FITNESS*
- ADVENTURE *PLUSH UPRIGHT COMFORT*

**OVERMOUNTAIN**

CLAYMORE	10-11
JEKYLL	12-17

**FULL SUSPENSION**

HEADSHOK	18-21
RZ ONE TWENTY	22-25
SCALPEL	26-29

**HARDTAIL**

FLASH CARBON	30-33
FLASH	34-35
TRAIL SL / TRAIL	36-39

**29'ER**

FLASH CARBON 29'ER	40-42
FLASH 29'ER	43
TRAIL SL 29'ER	44-45

# MOUNTAIN





**GO  
BIG.**

# OVERMOUNTAIN

DOES WHAT “ALL-MOUNTAIN” CAN’T.



CLAYMORE



JEKYLL



SCARLET

*The new OverMountain category from Cannondale is a family of go anywhere, ride anything, two-bikes-in-one superbikes that actually do what “all-mountain” bikes can only claim to do; excel at both climbing AND descending.*

*Until now, the “all-mountain” category has been synonymous with “compromise”— what’s good for going up is not so good for going down and vice versa. They demand different things – different travel, different suspension response, different geometry. That’s the inherent challenge of designing “all-mountain” bikes; working with one frame, one shock and one geometry forces you to choose what aspects of performance must be sacrificed to gain performance elsewhere.*

*Cannondale’s engineers realized that in order to break out of the boundaries and compromises that define the “all-mountain” category, they would have to create something new. We needed bikes that were light and stiff enough to satisfy the climbers, yet tough and precise enough to thrill the descenders. We needed bikes that could actually adapt to the differing demands of climbing versus descending; bikes that could instantly change their travel, damping, and geometry, all at the flick of a switch. Bikes that truly are two different bikes in one package. The result was OverMountain.*

*Work less on the climbs. Rip harder on the descents. Smile more everywhere.*

*Mountain biking just got a lot more fun.*

## Key OverMountain Technologies:



### 1 BALLISTEC CARBON CONSTRUCTION

With fibers developed for military ballistic armoring and resins developed for carbon baseball bats, **BallisTec** carbon is seriously tough stuff. Lighter and stiffer than aluminum, stronger and more durable than steel, **BallisTec** carbon can shake off rock strikes and impacts that would cripple the competition and their carbon “shields”. Launch with confidence.



### 2 SMARTFORMED ALLOY CONSTRUCTION

Cannondale's three decades of aluminum expertise are evident in the alloy **OverMountain** bikes. Sophisticated **SmartForming** techniques deliver incredibly precise wall thickness distribution and tube shapes, concentrating material exactly where needed to maximize strength and stiffness, while removing every last extraneous gram from the structure. Unlike the putty-and-paint “smooth” welds of the competition, Cannondale's legendary double-pass smooth welds eliminate stress risers, creating the strongest possible joints. Combine both with a heat-treat process that creates a true unibody structure, and you've got simply the finest aluminum frames money can buy.



### 3 ECS-TC (ENHANCED CENTER STIFFNESS-TORSION CONTROL) SYSTEM

A frame is only as stiff as its weakest parts. On dual suspension bikes, the weakest parts are often the crucial bearings and links that join the swingarm to the front triangle. The vague, imprecise sensation felt on so many bikes is caused by the subtle flex and movement that occurs in the connecting hardware as the loads on the bike shift from side-to-side. To create bikes that respond instantly to rider input and deliver unprecedented sensitivity and feedback, we designed a five-part system to eliminate flex and soft play in the bearings and links.

#### Ultra Wide Bearing Placement

Just like you are more stable standing with your feet apart than together, the further apart you can place cartridge bearings, the better they support each other and the stiffer the system can be. The **ECS-TC** system has the widest link-bearing spacing of any bike in the industry.

#### Double-Stacked Rear Dropout Pivot Bearings

At the rear dropout pivots, we double-stack the bearings, placing two side-by-side in each pivot. This greatly increases the seat stays' ability to resist twisting loads, making for an incredibly solid feeling swingarm.



#### X-12 Rear Thru-axle

Thru-axles are stiffer. We've integrated the **Syntaxe X-12** thru-axle and dropout system to provide the stiffness of a 12 mm thru-axle with the quick wheel changes and ease of use of a quick release wheel.

#### Double-Clamped 15 mm Thru-axles

With the **ECS-TC** system, 15 mm thru-axles are used for the swingarm pivot and both shock link pivots. By placing the bearings in the frame, then clamping the ends of the link to both sides of the axle, the axle becomes a structural part of the link/swingarm, tying the two sides together and radically increasing its ability to resist twisting loads.

#### Collet Shim Bearing Preload

An innovative bearing preload system eliminates any freeplay between the bearings and the links.



### 4 DYAD RT2 DUAL SHOCK

The heart of **OverMountain** is a radical new dual rear shock, the **FOX DYAD RT2**. For the first time ever, two completely different shocks are housed in one package: **Elevate** - a shorter travel, smaller volume air shock for rolling and climbing terrain, and **Flow** - a longer travel, high volume, linear air shock for aggressive descents. Each has its own dedicated damping circuit, fully optimized for its intended terrain and activated by a handlebar mounted lever. Rather than trying to make one shock do everything, we were free to create separate suspension responses for different needs - active and super efficient for the flats and climbs, ultra plush and bottomless for the descents. Switching between **Elevate** and **Flow** also changes the bike's sag height and geometry, keeping the rider in the proper position for the terrain: steep and forward for powering up, low and stable for shredding down. It is fundamentally like having two different bikes available to you at the flick of a switch.

*Elevate your soul and let it flow.*

# CLAYMORE

**THE ULTIMATE OVERMOUNTAIN MEGABIKE.**

**CLAYMORE. NAMED AFTER THE CLAUDHEAMH MÒR, THE LEGENDARY TWO-HANDED SCOTTISH BROADSWORD. FOR WARRIORS. PREPARE FOR BATTLE.**

## **BURLY BUT LIGHT**

Almost 30 years of aluminum expertise and our **SmartFormed** aluminum allows us to design and craft a frame that is up to the rigors of **OverMountain** riding while also remaining remarkably lightweight.

## **CLAYMORE SUSPENSION SYSTEM**

The radical **DYAD RT2** dual shock and **Claymore's** linear-to-progressive link leverage ratio are optimized for each other, providing incredible small bump response, traction and efficiency in the **Elevate** mode, and a fluid, bottomless feel in **Flow** mode.

## **ATTITUDE ADJUST**

The two-position shock mount allows the base geometry to be adjusted to suit the terrain and riding style. Then switching between the **DYAD** shock's two settings alters the **Claymore's** geometry on the fly: low and stable for flowing descents, steep and forward for efficient climbing.



## **CLAYMORE 1**

Magnesium White (gloss) (WHT).

**FRAME** Claymore, 180/110 mm, SmartFormed alloy, BB30, ISCG03, Diablo head tube  
**SUSPENSION (R/F)** Fox Dyad RT2/Fox 36 Talas RC2 FIT, 180 mm, 20QR  
**WHEELS** Mavic CrossMax SX, tubeless

**SHIFTERS** SRAM X9  
**REAR DERAILLEUR** SRAM X0, 10-speed  
**CRANK** SRAM S1400, BB30, 39/26

**BRAKES** Avid Elixir X0 carbon, 203/185 mm  
**TIRES** Schwalbe Fat Albert Pace/TrailStar, 2.4" tubeless ready  
**SIZES** S, M, L, X



## CLAYMORE 2

Jet Black (gloss) (BLK).

**FRAME** Claymore, 180/110 mm, SmartFormed alloy, BB30, ISCG03, Diablo head tube  
**SUSPENSION (R/F)** Fox Dyad RT2/Fox 36 Talas RC2 FIT, 180 mm, 20QR  
**WHEELS** SunRingle Charger Pro, tubeless ready

**SHIFTERS** Shimano SLX  
**REAR DERAILLEUR** Shimano XT, 10-speed  
**CRANK** SRAM S1400, BB30, 39/26

**BRAKES** Avid Elixir CR, 203/185 mm  
**TIRES** Schwalbe Fat Albert Pace/TrailStar, 2.4" tubeless ready  
**SIZES** S, M, L, X



## CLAYMORE 3

Jet Black (matte) (BBQ).

**FRAME** Claymore, 180/110 mm, SmartFormed alloy, BB30, ISCG03, Diablo head tube  
**SUSPENSION (R/F)** Fox Dyad RT2/Fox 36 Talas R, 180 mm, 20QR  
**WHEELS** Sun EQ27, 32 hole

**SHIFTERS** SRAM X7  
**REAR DERAILLEUR** SRAM X9 alloy, 10-speed  
**CRANK** TruVatV Fire-X AM 36/24 2.2

**BRAKES** Avid Elixir R, 203/185 mm  
**TIRES** Kenda Nevegal folding, 2.35"  
**SIZES** S, M, L, X

# JEKYLL



## JEKYLL ULTIMATE

**FRAME** Jekyll, 150/90mm, BallisTec Hi-MOD Carbon, BB30, ISCG03, 1.5 Si head tube  
**SUSPENSION (R/F)** Fox Dyad RT2/Fox 32 Talas RLC FIT, 150 mm 15QR  
**WHEELS** CrankBrothers Cobalt, tubeless

**SHIFTERS** SRAM XX  
**REAR DERAILLEUR** SRAM XX, 10-speed  
**CRANK** Cannondale Hollowgram SL, BB30, 39/26

Exposed Carbon w/Magnesium White accents (matte) (BBQ).  
**BRAKES** Avid Elixir X0 carbon, 185/185 mm  
**TIRES** Schwalbe Nobby Nic PaceStar, 2.4" tubeless ready  
**SIZES** S, M, L, X

# THE GO ANYWHERE, RIDE ANYTHING, TWO-BIKES-IN-ONE SUPERBIKE.

INDULGE BOTH SIDES OF YOUR PERSONALITY — NO POTIONS NEEDED. WITH THE REVOLUTIONARY DYAD SHOCK, JEKYLL IS BACK WITH A VENGEANCE AND REWRITING THE RULES ONCE AGAIN.



**1** **JEKYLL SUSPENSION SYSTEM**  
The radical **DYAD RT2** dual shock and the **Jekyll's** linear-to-progressive link leverage ratio are optimized for each other, providing incredible small bump response, traction and efficiency in the **Elevate** mode, and a fluid, bottomless feel in **Flow** mode.

**2** **GET CONNECTED**  
Your frame is only as stiff as its weakest parts. **Jekyll's** 5-part **ECS-TC** (Enhanced Center-Stiffness, Torsion Control) system eliminates unwanted flex and play in the links and pivots, unifying the frame and delivering unmatched responsiveness and control.

**3** **LIGHT AND TOUGH**  
In either **BallisTec** carbon or sophisticated **SmartFormed** alloy, the incredibly light, unbelievably tough **Jekyll** frames let you climb with the whippets, but descend with the pitbulls.







## JEKYLL CARBON 1

**FRAME** Jekyll, 150/90mm, BallisTec Hi-MOD Carbon, BB30, ISCG03, 1.5 Si head tube  
**SUSPENSION (R/F)** Fox Dyad RT2/Fox 32 Talas RLC FIT, 150 mm 15QR  
**WHEELS** SunRingle BlackFlag Pro, tubeless ready

**SHIFTERS** Shimano XT  
**REAR DERAILLEUR** Shimano XTR, 10-speed  
**CRANK** FSA SL-K BB30, 44/32/24

Magnesium White w/Berserker Green accents (gloss) (WHT2).

**BRAKES** Avid Elixir CR Carbon, 185/185 mm  
**TIRES** Schwalbe Nobby Nic PaceStar, 2.4" tubeless ready  
**SIZES** S, M, L, X



## JEKYLL CARBON 2

**FRAME** Jekyll, 150/90mm, BallisTec Hi-MOD Carbon, BB30, ISCG03, 1.5 Si head tube  
**SUSPENSION (R/F)** Fox Dyad RT2/Fox 32 Talas RL, 150 mm, 15QR  
**WHEELS** SunRingle BlackFlag Expert +, tubeless ready

**SHIFTERS** SRAM X9  
**REAR DERAILLEUR** SRAM X9, 10-speed  
**CRANK** FSA Afterburner BB30, 44/32/24

Charcoal Grey w/Jet Black accents (matte) (GRY).

**BRAKES** Avid Elixir CR, 185/185 mm  
**TIRES** Schwalbe Nobby Nic PaceStar, 2.4" tubeless ready  
**SIZES** S, M, L, X



### JEKYLL 3

Ultra Blue w/Single Malt Brown accents (gloss) (BLU).

Magnesium White w/Red and Black accents (gloss) (WHT).

**FRAME** Jekyll, 150/90mm, SmartFormed Alloy, BB30, ISCG03, 1.5 Si head tube  
**SUSPENSION (R/F)** Dyad RT2/Fox 32 Talas RL, 150 mm, 15QR  
**WHEELS** DT Swiss M480, 32 hole

**SHIFTERS** Shimano XT  
**REAR DERAILLEUR** Shimano XT, 10-speed  
**CRANK** FSA Afterburner BB30, 44/32/24

**BRAKES** Avid Elixir CR, 185/185 mm  
**TIRES** Schwalbe Nobby Nic PaceStar, 2.4" tubeless ready  
**SIZES** S, M, L, X



### JEKYLL 4

Magnesium White w/Red and Black accents (gloss) (WHT).

Vintage Moss w/Magnesium White accents (gloss) (GRN).

**FRAME** Jekyll, 150/90mm, SmartFormed Alloy, BB30, ISCG03, 1.5 Si head tube  
**SUSPENSION (R/F)** Fox Dyad RT2/Fox 32 Float RL, 150 mm, 15QR  
**WHEELS** Mavic XM317, 32 hole

**SHIFTERS** SRAM X7  
**REAR DERAILLEUR** SRAM X9, 9-speed  
**CRANK** Fire-X 3.3, 44/32/22

**BRAKES** Avid Elixir R, 185/185 mm  
**TIRES** Kenda Nevegal folding, 2.35"  
**SIZES** S, M, L, X



## JEKYLL 5

**FRAME** Jekyll, 150/90mm, SmartFormed Alloy, BB30, ISC603, 1.5 Si head tube

**SUSPENSION (R/F)** Fox Dyad RT2/RockShox Revelation, 150 mm, Dual Air, All Travel, 15 mm thru

**WHEELS** Sun SR25, 32 hole

**SHIFTERS** SRAM X7

**REAR DERAILLEUR** SRAM X7, 9-speed

**CRANK** Fire-X 3.1, 44/32/22

**BRAKES** Avid Elixir 3, 185/185 mm

**TIRES** Kenda Nevegal folding, 2.35"

**SIZES** S, M, L, X

Orange Spice, Magnesium White (gloss) (ORG).

Magnesium White w/Red and Black accents (gloss) (WHT).

# LEFTY/HEADSHOK

## WHY LEFTY?

**Lighter. Stronger. Stiffer. Smoother.**  
No matter what other fork you are riding, Lefty is better. The radical Lefty front suspension system has had people scratching their heads for over ten years now. It's time to set the record straight.

### **Lefty is LIGHTER.**

The Lefty Speed Carbon weighs an unbelievable 2.64 lbs. At just 3.11 lbs, the heaviest model in the Lefty lineup is lighter than most competitors' lightest race offerings.

### **Lefty is STRONGER.**

Cross country weight meets dirt jumper tough. Lefty's unconventional inverted design, with its oversized steerer, massive outer tube and beefy dual crowns, allows even the lightest Lefty to go head to head in destructive testing with forks designed for much more abusive riding.

### **Lefty is STIFFER.**

Lefty's stout structure combined with its "square in a square" stanchion design allow it to post deflection numbers comparable to the burliest thru-axle forks, while weighing less than the lightest XC forks.

### **Lefty is SMOOTHER.**

The heart of the Lefty design, Cannondale's patented 88 Needle Bearing Technology keeps the suspension rolling fluidly, regardless of load. Hard braking, impacts, and steering forces have no effect on the shock's ability to move, keeping the wheel tracking the ground and the rider in total control.



#### **LEFTY CARBON W/XLR**

XLoc REMOTE HYDRAULIC LOCKOUT AND REBOUND ADJUST. EQUIPPED WITH POPTOP BLOW-OFF THRESHOLD LOCKOUT PISTON.

# CONVENTION IS FOR THE WEAK.

QUANTUM LEAPS IN ENGINEERING AND PERFORMANCE ONLY COME WHEN YOU CAST OFF CONVENTIONAL DESIGN. FREE YOURSELF FROM THE HERD.



## LEFTY W/PBR

GLOVE-FRIENDLY PUSH BUTTON LOCKOUT AND REBOUND ADJUST. EQUIPPED WITH POPTOP BLOW-OFF THRESHOLD LOCKOUT PISTON.

## 1 DON'T SLIDE, ROLL

Rather than sliding on traditional bushings, **Lefty** rolls on precision-ground needle bearings and hardened steel races, eliminating friction and allowing **Lefty's** suspension to stay plush and active in all situations. Regular bushings can bind and limit fork movement precisely when you need it most.

## 2 OPI (ONE PIECE INTEGRATION)

Our complex 3D forging process, used for parts like the **OPI** inner leg, the **OPI** outer leg/clamp, and the **OPI** Stem/Steerer, integrates multiple parts into single forged pieces, drastically reducing weight and increasing strength.

## 3 SUPERIOR DESIGN

**Lefty's** inverted double clamp design is stiffer, stronger and lighter than the traditional single crown designs. System Integrate with the **Si** Stem/Steerer for the lightest, most precise front suspension system available anywhere.

LEARN MORE AT [WWW.CANNONDALE.COM](http://WWW.CANNONDALE.COM)

# LEFTY/HEADSHOK



## LEFTY MAX

140 MM OF TRAVEL  
ALL-MOUNTAIN RIDING

MODEL	<b>LEFTY MAX CARBON XLR</b>
STRUCTURE	Filament-wound Carbon Fiber outer leg, OPI inner leg
DAMPER	XLR remote lockout, rebound adj, blowoff threshold
SPRING	SOLO AIR w/self adjusting neg spring
WEIGHT	2.99 lbs / 1356 grams



## LEFTY ULTRA

120 MM OF TRAVEL  
TRAIL RIDING / MARATHON RACING

MODEL	<b>LEFTY ULTRA CARBON PBR</b>
STRUCTURE	Filament-wound Carbon Fiber outer leg, OPI inner leg
DAMPER	PBR push button lockout, rebound adj, blowoff threshold
SPRING	SOLO AIR w/self adjusting neg spring
WEIGHT	2.78 lbs / 1259 grams



MODEL	<b>LEFTY ULTRA PBR</b>
STRUCTURE	OPI Alloy outer leg, OPI inner leg
DAMPER	PBR push button lockout, rebound adj, blowoff threshold
SPRING	SOLO AIR w/self adjusting neg spring
WEIGHT	3.07 lbs / 1392 grams



## LEFTY SPEED

100 MM OF TRAVEL  
XC RACING

MODEL	<b>LEFTY SPEED CARBON XLR</b>
STRUCTURE	Filament-wound Carbon Fiber outer leg, OPI inner leg
DAMPER	XLR remote lockout, rebound adj, blowoff threshold
SPRING	SOLO AIR w/self adjusting neg spring
WEIGHT	2.76 lbs / 1251 grams



MODEL	<b>LEFTY SPEED CARBON PBR</b>
STRUCTURE	Filament-wound Carbon Fiber outer leg, OPI inner leg
DAMPER	PBR push button lockout, rebound adj, blowoff threshold
SPRING	SOLO AIR w/self adjusting neg spring
WEIGHT	2.64 lbs / 1197 grams



MODEL	<b>LEFTY SPEED XLR</b>
STRUCTURE	OPI Alloy outer leg, OPI inner leg
DAMPER	XLR remote lockout, rebound adj, blowoff threshold
SPRING	SOLO AIR w/self adjusting neg spring
WEIGHT	3.08 lbs / 1397 grams



MODEL	<b>LEFTY SPEED PBR</b>
STRUCTURE	OPI Alloy outer leg, OPI inner leg
DAMPER	PBR push button lockout, rebound adj, blowoff threshold
SPRING	SOLO AIR w/self adjusting neg spring
WEIGHT	2.94 lbs / 1333 grams

## LEFTY 29'ER

90 MM OF TRAVEL  
XC RACING / TRAIL RIDING



MODEL	<b>LEFTY 29'ER CARBON XLR</b>	<b>LEFTY 29'ER CARBON PBR</b>	<b>LEFTY 29'ER PBR</b>
STRUCTURE	Filament-wound Carbon Fiber outer leg, OPI inner leg	Filament-wound Carbon Fiber outer leg, OPI inner leg	OPI Alloy outer leg, OPI inner leg
DAMPER	XLR remote lockout, rebound adj, blowoff threshold	PBR push button lockout, rebound adj, blowoff threshold	PBR push button lockout, rebound adj, blowoff threshold
SPRING	SOLO AIR w/self adjusting neg spring	SOLO AIR w/self adjusting neg spring	SOLO AIR w/self adjusting neg spring
WEIGHT	2.94 lbs / 1333 grams	3.04 lbs / 1379 grams	3.11 lbs / 1410 grams

## FATTY

80 MM OF TRAVEL  
XC RACING / TRAIL RIDING



MODEL	<b>FATTY DLR80</b>	<b>SOLO DL50</b>	<b>FATTY SOLO DL50</b>
TRAVEL	80 mm	50 mm	50 mm
STRUCTURE	Air Formed OPI Fatty Blades	Air Formed OPI Fatty Blades	OPI Solo Blade
DAMPER	DLR - oil damped, lockout lever, rebound adjust	DL - oil damped, lockout lever	DL - oil damped, lockout lever
SPRING	Cartridge Air Spring, coil negative	Coil Spring/elastomer	Coil Spring/elastomer
WEIGHT	2.80 lbs / 1270 grams	2.98 lbs / 1351 grams	3.2 lbs / 1451 grams

# RZ ONE TWENTY

**DISTILLED TO PERFECTION.**

**SIMPLICITY HAS ITS MERITS. THE RZ ONE TWENTY'S REFINED MODIFIED SINGLE PIVOT SUSPENSION DESIGN DELIVERS A RIDE THAT IS SUPREMELY BALANCED, EFFICIENT AND PRECISE.**

## STAGED TRAVEL

Refined single pivot design delivers optimal suspension performance throughout the travel, ultra plush at the start, then linear and efficient through the middle of the stroke, then gets progressively firmer at the end for a bottomless feel.

## ALUMINUM CRAFTING

From the OPI (One Piece Integrated) Backbone to the SmartFormed aluminum and trademark double-pass welds, RZ One Twenty is the pinnacle of aluminum crafting.

## SUPERB HANDLING

The RZ's geometry splits the difference between our more aggressive Jekyll and racy Scalpel. Quick enough for technical trail riding, stable enough to keep you out of trouble while dropping your favorite sketchy section.



## RZ ONE TWENTY 1

**FRAME** RZ One Twenty, 120 mm, SmartFormed alloy, BB30, 1.5 SI head tube  
**SUSPENSION (R/F)** RockShox Monarch RT3/Lefty Ultra PBR, 120 mm  
**WHEELS** Mavic XM317, 32 hole

Magnesium White w/Red and Black accents (gloss) (WHT).

**SHIFTERS** SRAM X9  
**REAR DERAILLEUR** SRAM X9, 10-speed  
**CRANK** FSA Afterburner 386 BB30, 39-27

Jet Black (matte) (BBQ).

**BRAKES** Avid Elixir R Carbon, 185/160 mm  
**TIRES** Schwalbe Rocket Ron Performance, 2.1" folding  
**SIZES** S, M, L, X





Berserker Green (gloss) (GRN).



Fine Silver (gloss) (SLV).

## RZ ONE TWENTY 2

**FRAME** RZ One Twenty, 120 mm, SmartFormed alloy, BB30, 1.5 Si head tube  
**SUSPENSION (R/F)** Fox RP2/Lefty Ultra PBR, 120 mm  
**WHEELS** Mavic XM317, 32 hole

**SHIFTERS** Shimano XT  
**REAR DERAILLEUR** Shimano XT, 10-speed  
**CRANK** Shimano M552, 42/32/24

**BRAKES** Hayes Stroker Trail Carbon, 180/160 mm  
**TIRES** Kenda Slant 6, 2.1", folding  
**SIZES** S, M, L, X



### RZ ONE TWENTY 3

**FRAME** RZ One Twenty, 120 mm, SmartFormed alloy, BB30, 1.5 Si head tube  
**SUSPENSION (R/F)** X Fusion 02 RL2/ RockShox Recon Silver TK, 120 mm, 20 mm thru  
**WHEELS** Mavic XM317, 32 hole

Nu Team Blue (gloss) (BLU).

**SHIFTERS** SRAM X7  
**REAR DERAILLEUR** SRAM X9, 9-speed  
**CRANK** Shimano M542, 44/32/22



Jet Black (gloss) (BLK).

**BRAKES** Avid Elixir 3, 180/160 mm  
**TIRES** Kenda Slant 6 wire bead, 2.1"  
**SIZES** S, M, L, X



### RZ ONE TWENTY 4

**FRAME** RZ One Twenty, 120 mm, SmartFormed alloy, BB30, 1.5 Si head tube  
**SUSPENSION (R/F)** X Fusion 02 RL2/ RST Deuce Air, 120 mm, 15 mm thru  
**WHEELS** Maddux, 32 hole

Race Red (gloss) (RED).

**SHIFTERS** Shimano Deore  
**REAR DERAILLEUR** Shimano Deore, 9-speed  
**CRANK** Shimano M430-8, 44/32/22



Magnesium White w/Red and Black accents (gloss) (WHT).

**BRAKES** Shimano M445 (hydraulic disc), 180/160 mm  
**TIRES** Kenda Slant 6 wire bead, 2.1"  
**SIZES** S, M, L, X



# SCALPEL



## SCALPEL ULTIMATE

Team Replica (gloss) (REP).

<b>FRAME</b> Scalpel, 80 mm, BallisTec Hi-MOD Carbon, BB30, 1.5 Si head tube	<b>SHIFTERS</b> SRAM XX	<b>BRAKES</b> SRAM XX, 160/140 mm
<b>SUSPENSION (R/F)</b> RockShox Monarch RT3/Lefty Speed Carbon XLR, 100 mm	<b>REAR DERAILLEUR</b> SRAM XX, 10-speed	<b>TIRES</b> Schwalbe, Racing Ralph PaceStar 2.1" (F), Furious Fred PaceStar 2.0" (R)
<b>WHEELS</b> DT Swiss XCR 1.2 Custom	<b>CRANK</b> Cannondale Hollowgram SL, 42-28 w/XX chainrings	<b>SIZES</b> S, M, L, X

# ZERO PIVOTS, ZERO COMPETITION.

THE LIGHTEST, STIFFEST, MOST EFFICIENT DUAL SUSPENSION XC RACE BIKE ON THE PLANET. THE SCALPEL ISN'T JUST IN A CLASS BY ITSELF - IT'S ATTENDING AN ENTIRELY DIFFERENT SCHOOL.



**1 ZERO PIVOT**  
No bearings, no bushings, nothing to add weight or cause play, just chain stays and seat stays engineered to flex along a given path, providing 80 mm of plush, progressive travel.

**2 SYSTEM INTEGRATION**  
Scalpel achieves unheard of levels of light weight and efficiency by System Integration design. We craft components to work together, like the Lefty fork and Si Stem/Steerer, or the Si/SL Hollowgram crankset with our BB30 system.

**3 BALLISTEC CARBON**  
Lighter and stiffer than aluminum, more dent resistant than steel, BallisTec carbon can shake off rock strikes and impacts that would destroy Scalpel's flimsy competition. And the Scalpel frame weighs just 1580 grams complete with shock.

**WORLD CHAMPIONSHIPS**



**SCALPEL 1**

<b>FRAME</b> Scalpel, 80 mm, BallisTec Hi-MOD Carbon, BB30, 1.5 Si head tube	<b>SHIFTERS</b> Shimano XTR	Magnesium White w/Jet Black accents (gloss) (WHT).
<b>SUSPENSION (R/F)</b> Fox RP23 BoostValve/Lefty Speed Carbon PBR, 100 mm	<b>REAR DERAILLEUR</b> Shimano XTR, 10-speed	<b>BRAKES</b> Magura Marta SL Carbon, 160/140 mm
<b>WHEELS</b> Mavic CrossMax SLR Lefty, tubeless	<b>CRANK</b> FSA SL-K 386 BB30, 42-27	<b>TIRES</b> Schwalbe Racing Ralph PaceStar, 2.1" tubeless ready
		<b>SIZES</b> S, M, L, X



**SCALPEL 2**

<b>FRAME</b> Scalpel, 80 mm, BallisTec Hi-MOD Carbon, BB30, 1.5 Si head tube	<b>SHIFTERS</b> SRAM X0	Charcoal Grey w/Jet Black accents (gloss) (GRY).
<b>SUSPENSION (R/F)</b> RockShox Monarch RT3/Lefty Speed XLR, 100 mm	<b>REAR DERAILLEUR</b> SRAM X0, 10-speed	<b>BRAKES</b> Avid Elixir CR carbon, 160/140 mm
<b>WHEELS</b> SunRingle BlackFlag Pro, 24 hole, tubeless ready	<b>CRANK</b> FSA Afterburner 386 BB30, 42-27	<b>TIRES</b> Schwalbe Racing Ralph PaceStar, 2.1" tubeless ready
		<b>SIZES</b> S, M, L, X



Adam Campbell



NATIONAL CHAMPIONSHIPS

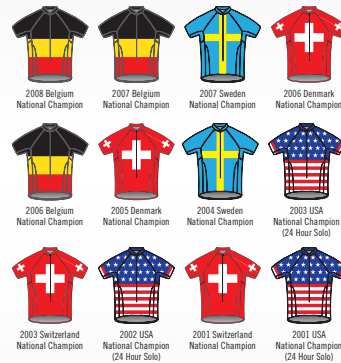

SCALPEL 3

**FRAME** Scalpel 80 mm-zero pivot, BallisTec, Hi-MOD carbon, BB30, 1.5 Si head tube  
**SUSPENSION (R/F)** Lefty Speed w/PBR, 100 mm  
**WHEELS** DT Swiss XCR 1.7 Custom

**SHIFTERS** Shimano SLX  
**REAR DERAILLEUR** Shimano XT, 10-speed  
**CRANK** FSA Afterburner 386 BB30, 42-27

Jet Black w/Magnesium White accents (gloss) (BLK).  
**BRAKES** Avid Elixir R, 160/140 mm  
**TIRES** Schwalbe Racing Ralph PaceStar, 2.1" tubeless ready  
**SIZES** S, M, L, X

# FLASH CARBON

**950 GRAMS OF IMPOSSIBLE.**

**THE WORLD'S BEST HARDTAIL. LIGHTER THAN MOST ELITE CARBON ROADBIKES, TOUGHER THAN MOST ALUMINUM BIKES, STIFFER AND MORE COMPLIANT THAN TITANIUM. SCIENCE FICTION BECOMES ENGINEERING FACT.**

## SAVE MICRO-SUSPENSION SYSTEM

Flattened **SAVE** cross-sections and sophisticated carbon layup on the **Flash** chain stays, seat stays and seatpost act like a micro-suspension system, deflecting vertically to absorb trail shock and vibration, while staying extremely rigid laterally for power transfer and confident cornering.

## BALLISTEC CARBON TECHNOLOGY

**BallisTec** carbon and sophisticated layup techniques deliver unmatched toughness and the world's best stiffness-to-weight ratio.\*

\* Frame independently tested at Zedler Fahrradtechnik, February 27, 2009.

## SYSTEM INTEGRATION

Ignoring the common "bolt-on" spec mentality, our System Integration design approach (**Lefty** fork, **OPI** Stem/Steerer, and **Hollowgram Si SL** cranks) produces an overall weight that our competitors can only dream of.



## FLASH ULTIMATE

Team Replica (gloss) (REP).

**FRAME** Flash, BallisTec Hi-MOD Carbon, SAVE, BB30 1.5 Si head tube

**SHIFTERS** SRAM XX

**BRAKES** SRAM XX, 160/140 mm

**FORK** Lefty Speed Carbon XLR, 100 mm

**REAR DERAILLEUR** SRAM XX, 10-speed

**TIRES** Schwalbe, Racing Ralph PaceStar 2.1" (F), Furious Fred PaceStar 2.0" (R)

**WHEELS** DT Swiss XCR 1.2 Custom

**CRANK** Cannondale Hollowgram SL, 42-28 w/XX chainrings

**SIZES** S, M, L, X





CANNONDALE  
FACTORY RACING

SYSTEM INTEGRATION

M4

(ZEROPIVOT)

Lefty



**PALMARÉS**



2010 Italian National Champion



2009 Belgian National Champion



2009 Italian National Champion



2009 Team Relay World Champion



**FLASH HI-MOD 1**

Magnesium White w/Jet Black accents (gloss) (WHT).

**FRAME** Flash, BallisTec Hi-MOD Carbon, SAVE, BB30 1.5 Si head tube  
**FORK** Lefty Speed Carbon PBR, 100 mm  
**WHEELS** Mavic CrossMax SLR Lefty, tubeless

**SHIFTERS** Shimano XTR  
**REAR DERAILLEUR** Shimano XTR, 10-speed  
**CRANK** FSA K-Force 386 BB30, 42-27

**BRAKES** Magura Marta SL Carbon, 160/140 mm  
**TIRES** Schwalbe Racing Ralph PaceStar, 2.1" tubeless ready  
**SIZES** S, M, L, X



**FLASH CARBON 4**

Race Red w/Magnesium White accents (gloss) (RED).

**FRAME** Flash, BallisTec Carbon, SAVE, BB30 1.5 Si head tube  
**FORK** Lefty Speed PBR, 100 mm  
**WHEELS** Mavic XM317, 32 hole

**SHIFTERS** SRAM X7  
**REAR DERAILLEUR** SRAM X9, 10-speed  
**CRANK** SRAM S1400 BB30, 42-27

**BRAKES** Avid Elixir R, 160/160 mm  
**TIRES** Schwalbe Rocket Ron Performance, 2.1" folding  
**SIZES** S, M, L, X



# FLASH

**PURE AND SIMPLE.**

**AN ALUMINUM CLONE OF OUR BOUNDARY-BREAKING FLASH CARBON, THE FLASH ALLOY IS EVERYTHING YOU NEED AND NOTHING YOU DON'T.**

## **SUPER LIGHT WEIGHT**

At 1450 grams, **Flash Alloy** is lighter than most of our competitor's carbon offerings.

## **CANNONDALE ALUMINUM**

**Flash's** sophisticated **SmartFormed** tubing manipulation and our trademark double-pass smooth welds reflect our almost 30 years of aluminum supremacy.

## **SAVE MICRO-SUSPENSION SYSTEM**

Careful shaping and wall thickness manipulation on the chain stays and seat stays allows them to deflect vertically while remaining stiff laterally and torsionally, absorbing shock and enhancing control.



## **FLASH F1**

Magnesium White (gloss) (WHT).

**FRAME** Flash, SmartFormed Alloy, SAVE, BB30, 1.5 Si head tube

**SHIFTERS** SRAM X7

**BRAKES** Avid Elixir R, 160/160 mm

**FORK** Lefty Speed PBR, 100 mm

**REAR DERAILLEUR** SRAM X9, 10-speed

**TIRES** Kenda Small Block Eight, 2.1", folding

**WHEELS** Mavic XM317, 32 hole

**CRANK** FSA Afterburner 386 BB30, 39/27

**SIZES** S, M, L, X



## FLASH F2

Race Red (gloss) (RED).

**FRAME** Flash, SmartFormed Alloy, SAVE, BB30, 1.5 Si head tube

**SHIFTERS** Shimano SLX

**BRAKES** Shimano BR-M505, 160/160 mm

**FORK** Lefty Speed PBR, 100 mm

**REAR DERAILLEUR** Shimano XT, 9-speed

**TIRES** Kenda Small Block Eight, 2.1", folding

**WHEELS** Mavic XM317, 32 hole

**CRANK** Shimano M542, 44/32/22

**SIZES** S, M, L, X



## FLASH F3

Jet Black (matte) (BBQ).

Magnesium White (gloss) (WHT).

**FRAME** Flash, SmartFormed Alloy, SAVE, BB30, 1.5 head tube

**SHIFTERS** SRAM X7

**BRAKES** Hayes Ryde Comp, 160/160 mm

**FORK** Fatty DLR80, 80 mm

**REAR DERAILLEUR** SRAM X7, 9-speed

**TIRES** Kenda Slant 6, 2.1"

**WHEELS** Maddux DC3.0, double wall w/eyelet, 32 hole

**CRANK** Shimano FC-M430-8, 44/32/22

**SIZES** S, M, L, X



# TRAIL SL / TRAIL

**GET ON THE TRAIL.**

**YOUR JOURNEY BEGINS HERE. WELCOME TO THE WORLD OF TWO WHEELS AND FAT TIRES. YOUR TRAIL AWAITS. WHERE IT TAKES YOU IS ENTIRELY UP TO YOU.**

## RACE GEOMETRY

Trail SL is a racer through and through. It shares the geometry and many of the features of its Flash brethren.

## ALUMINUM CRAFTING

Trail and Trail SL's mechanically formed aluminum and our trademark double-pass smooth welds highlight Cannondale's aluminum expertise.

## SAVE MICRO-SUSPENSION SYSTEM

Optimized chain stay and seat stay shaping provides lateral rigidity while providing vertical compliance for bump absorption and comfort with no loss in power transfer.



## TRAIL SL 2

**FRAME** Trail SL Optimized 6061 Alloy, SAVE, 1.5" head tube

**FORK** RockShox Recon Silver TK, 100 mm

**WHEELS** Maddux DC3.0, double wall w/eyelet, 28/32 hole

Nu Team Blue (gloss) (BLU).

**SHIFTERS** Shimano Deore Trigger

**REAR DERAILLEUR** Shimano Deore, 9-speed

**CRANK** Shimano FC-M430-8, 44/32/22

Jet Black (gloss) (BLK).

**BRAKES** Shimano BR-M445 Hydraulic Disc, 160/160 mm

**TIRES** Kenda Small Block 8, 2.1"

**SIZES** S, M, L, X, J



### TRAIL SL 3

**FRAME** Trail SL, Optimized 6061 Alloy, SAVE, 1.5" head tube  
**FORK** RST Deuce Coil, 100 mm, 15 mm thru  
**WHEELS** Maddux DC3.0, double wall w/eyelet, 28/32 hole

Jet Black (matte) (BBQ).

**SHIFTERS** SRAM X5  
**REAR DERAILLEUR** SRAM X5, 9-speed  
**CRANK** Shimano FC-M430-8, 44/32/22

Magnesium White (gloss) (WHT).

**BRAKES** Tektro Draco SL Custom Hydraulic Disc, 160/160 mm  
**TIRES** Kenda Small Block 8, 2.1"  
**SIZES** S, M, L, X, J



### TRAIL SL 4

**FRAME** Trail SL, Optimized 6061 Alloy, SAVE, 1.5" head tube  
**FORK** RST Deuce TNL, 100 mm  
**WHEELS** Alex DC4.5, double wall, 28/32 hole

Race Red (gloss) (RED).

**SHIFTERS** Shimano Alivio  
**REAR DERAILLEUR** Shimano Alivio, 8-speed  
**CRANK** Shimano FC-M361, 42/32/22

Fine Silver (matte) (SLV).

**BRAKES** Promax Orange Mechanical Disc, 160/160 mm  
**TIRES** Kenda Small Block 8, 2.1"  
**SIZES** S, M, L, X, J



Nu Team Blue (gloss) (BLU).



Jet Black (gloss) (BLK2).

## TRAIL 5

**FRAME** Trail, double butted 6061 Alloy, SAVE, 1-1/8" head tube

**FORK** RST Gila Pro TNL, 100 mm

**WHEELS** Alex DC4.5, double wall, 32 hole

**SHIFTERS** Shimano Alivio

**REAR DERAILLEUR** Shimano Alivio, 8-speed

**CRANK** FC-M311, 42/32/22

**BRAKES** Promax Orange Mechanical Disc, 160/160 mm

**TIRES** Kenda Small Block 8, 2.1"

**SIZES** S, M, L, X, J



Soldier of Fortune (matte) (GRN).



Magnesium White (matte) (WHT).

## TRAIL 6

**FRAME** Trail, double butted 6061 Alloy, SAVE, 1-1/8" head tube

**FORK** RST Gila T, 100 mm

**WHEELS** Alex DC4.5, double wall, 32 hole

**SHIFTERS** Shimano Acera

**REAR DERAILLEUR** Shimano Acera, 8-speed

**CRANK** FC-M191, 42/34/24

**BRAKES** Tektro Novela Mechanical Disc, 160/160 mm

**TIRES** Kenda Small Block 8, 2.1"

**SIZES** S, M, L, X, J





*Established in Milwaukee*

355 ml

**Pabst**  
**Blue Ribbon**  
BEER

**ORIGINAL** Pabst Blue Ribbon Beer  
...vide its prized flavor. Only the  
...Selected as America's...

# FLASH CARBON 29'ER



## FLASH HI-MOD 29'ER 1

Exposed Carbon w/Magnesium White accents (matte) (BBQ).

**FRAME** Flash 29'er, BallisTec Hi-MOD Carbon, SAVE, BB30 1.5 Si head tube

**SHIFTERS** SRAM X0

**BRAKES** SRAM X0, 185/160 mm

**FORK** Lefty 29'er Carbon XLR, 90 mm

**REAR DERAILLEUR** SRAM X0, 10-speed

**TIRES** Schwalbe Racing Ralph PaceStar, 2.25" tubeless ready

**WHEELS** Stan's ZTR Arch 29'er, 32 hole

**CRANK** Cannondale Hollowgram SL, 39-26 w/XX chainring

**SIZES** M, L, X

# GO BIGGER.

FROM THE SEA OTTER CLASSIC TO THE 2745 MILE TOUR DIVIDE, THE FLASH'S BIG WHEELS JUST KEEP ON TURNIN'. ROLL ON.



**1 BALLISTEC CARBON FIBER**  
Lighter and stiffer than aluminum, more dent resistant than steel, the super tough **BallisTec** carbon can shake off rock strikes and impacts that would destroy **Flash's** lightweight competition.

**2 SAVE MICRO-SUSPENSION SYSTEM**  
Flattened **SAVE** cross-sections and sophisticated carbon layup on the **Flash** rear stays and seatpost act like a micro-suspension system, deflecting vertically to absorb trail shock, while staying extremely rigid laterally for power transfer and confident cornering.

**3 LEFTY SYSTEM INTEGRATION**  
29'er fans have figured out that the **Lefty's** incredible stiffness, plushness and feathery light weight make it the perfect solution for 29'er front ends. When System Integrated with the ultra-light, ultra-stiff **OPI Stem/Steerer** it's an almost unfair advantage.



### FLASH CARBON 29'ER 2

Magnesium White w/Jet Black accents (gloss) (WHT).

**FRAME** Flash, BallisTec Carbon, SAVE, BB30 1.5 Si head tube

**SHIFTERS** SRAM X9

**BRAKES** Avid Elixir CR carbon, 185/160 mm

**FORK** Lefty 29'er Carbon PBR, 90 mm

**REAR DERAILLEUR** SRAM X9, 10-speed

**TIRES** Schwalbe Racing Ralph PaceStar, 2.25" tubeless ready

**WHEELS** Stan's ZTR Arch 29'er, 32 hole

**CRANK** FSA SL-K 386 BB30, 39-27

**SIZES** M, L, X



### FLASH CARBON 29'ER 3

Magnesium White w/Race Red accents (gloss) (RED).

**FRAME** Flash, BallisTec Carbon, SAVE, BB30 1.5 Si head tube

**SHIFTERS** SRAM X7

**BRAKES** Avid Elixir CR, 185/160 mm

**FORK** Lefty 29'er PBR, 90 mm

**REAR DERAILLEUR** SRAM X9, 10-speed

**TIRES** Schwalbe Racing Ralph PaceStar, 2.25" tubeless ready

**WHEELS** Sun EQ25 29'er, welded w/eyelet, 32 hole

**CRANK** FSA Afterburner 386 BB30, 39-27

**SIZES** M, L, X



## FLASH 29'ER 1

Jet Black (gloss) (BLK).

**FRAME** Flash, SmartFormed Alloy, SAVE, BB30 1.5 Si head tube

**SHIFTERS** SRAM X7

**BRAKES** Avid Elixir R, 185/160 mm

**FORK** Lefty 29'er PBR, 90 mm

**REAR DERAILLEUR** SRAM X9, 10-speed

**TIRES** Kenda Small Block 8, 2.1"

**WHEELS** Sun EQ25 29'er, welded w/eyelet, 32 hole

**CRANK** FSA Afterburner 386 BB30, 39-27

**SIZES** M, L, X



## FLASH 29'ER 2

Magnesium White (gloss) (WHT).

**FRAME** Flash, SmartFormed Alloy, SAVE, BB30 1.5 Si head tube

**SHIFTERS** Shimano SLX

**BRAKES** Shimano BR-505 hydraulic disc, 160/160 mm

**FORK** Lefty 29'er PBR, 90 mm

**REAR DERAILLEUR** Shimano XT, 10-speed

**TIRES** Kenda Small Block 8, 2.1"

**WHEELS** Sun SR25 29'er, welded w/eyelet, 32 hole

**CRANK** Shimano M542, 44/32/22

**SIZES** M, L, X

# TRAIL SL 29'ER

**WANNA TRY SOMETHING NEW?**

**TRAIL SL 29'ER MAKES AN IDEAL FIRST MOUNTAIN BIKE. THE BIG WHEELS ROLL OVER OBSTACLES WITH EASE, ABSORB BUMPS AND MAINTAIN MOMENTUM BETTER. GIVE YOURSELF AN EDGE.**

## RELAXED RACE GEOMETRY

Trail SL 29'er geometry features a slightly longer wheelbase and slacker head angle than the Flash for a stable, confidence-inspiring ride.

## SAVE MICRO-SUSPENSION SYSTEM

Optimized chain stay and seat stay shaping provides lateral rigidity while providing vertical compliance for bump absorption and comfort with no loss in power transfer.

## SINGLE-SPEED SIMPLICITY

For those who crave purity, simplicity and flow, the Trail SL 29'er is offered in a single-speed version with a 1.5" Fatty Rigid fork. If the mood hits, vertical dropouts and an eccentric BB mean that you can run full gears with just a quick swap of the derailleur hanger.



## TRAIL SL 29'ER 2

**FRAME** Trail SL 29'er, Optimized 6061 alloy, SAVE, 1.5" head tube  
**FORK** RST Duce 29 Air, 80 mm  
**WHEELS** Maddux DC3.0, 29'er, double wall w/eyelet, 32 hole

**SHIFTERS** Shimano Deore  
**REAR DERAILLEUR** Shimano Deore, 9-speed  
**CRANK** Shimano FC-M430-8 Octalink, 44/32/22

Race Red (gloss) (RED).

Jet Black (matte) (BBQ).

**BRAKES** Shimano BR-M445 hydraulic disc, 160/160 mm  
**TIRES** Kenda Small Block 8, 2.1"  
**SIZES** M, L, X



### TRAIL SL 29'ER 3

Lightning White (gloss) (WHT).

<b>FRAME</b>	Trail SL 29'er SS, Optimized 6061 alloy, SAVE, 1.5" head tube, Ecc. BB	<b>SHIFTERS</b>	N/A	<b>BRAKES</b>	Promax Orange Mechanical Disc, 160/160 mm
<b>FORK</b>	Cannondale Fatty Rigid 29'er	<b>GEARING</b>	33 x 20 T	<b>TIRES</b>	Kenda Small Block 8, 2.1"
<b>WHEELS</b>	Maddux DC3.0, 29'er, double wall w/eyelet, 32 hole	<b>CRANK</b>	TruVatiV Isoflow 1.0g SS, 33T	<b>SIZES</b>	M, L, X



### TRAIL SL 29'ER 4

Berserker Green (gloss) (GRN).

Fine Silver (matte) (SLV).

<b>FRAME</b>	Trail SL 29'er, Optimized 6061 alloy, SAVE, 1.5" head tube	<b>SHIFTERS</b>	Shimano Alivio	<b>BRAKES</b>	Promax Orange Mechanical Disc, 160/160 mm
<b>FORK</b>	RST Deuce 29 TNL, 80 mm	<b>REAR DERAILLEUR</b>	Shimano Alivio, 8-speed	<b>TIRES</b>	Kenda Small Block 8, 2.1"
<b>WHEELS</b>	Alex DC4.5, 29'er, double wall, 32 hole	<b>CRANK</b>	FSA Alpha Drive, 42/32/22	<b>SIZES</b>	M, L, X



**ELITE ROAD**

SUPERSIX 48-53

CAAD10 54-57

CAAD8 58-59

**PERFORMANCE ROAD**

SYNAPSE 60-65

**TRIATHLON / TIME TRIAL**

SLICE 66-69

**CYCLOCROSS**

SUPERX 70-73

CAADX 74-75

**ROAD**



*GO  
PRO.*



# SUPERSIX



## SUPERSIX HI-MOD TEAM

<b>FRAME</b> SuperSix Hi-MOD, BB30	<b>SHIFTERS</b> Campagnolo Super Record QS Carbon ErgoShifters, 11-speed	<b>BRAKES</b> Campagnolo Super Record D-Skeleton
<b>FORK</b> SuperSix, Hi-MOD full carbon, 1-1/8"-1.5" steerer	<b>REAR DERAILLEUR</b> Campagnolo Super Record, 11-speed	<b>TIRES</b> Schwalbe Ultremo ZX, 700 x 23c
<b>WHEELS</b> Mavic Cosmic Carbone SR	<b>CRANK</b> Cannondale Hollowgram SL BB30, 53/39 (Includes 50/34 rings & spider)	<b>SIZES</b> 48, 50, 52, 54, 56, 58, 60, 63cm

Liquigas Team Replica (gloss) (LIQ).

## WHERE ENGINEERING BECOMES ART.

CHAMPION OF THE 2010 GIRO D'ITALIA.  
HERO OF THE TOUR OF CALIFORNIA.  
AT JUST 890 GRAMS, WITH UNMATCHED  
STIFFNESS-TO-WEIGHT AND AN ALIVE,  
COMMUNICATIVE RIDE-FEEL,  
SUPERSIX IS ENGINEERED TO WIN.



### 1 POWER TRANSFER BEATBOX

Massively oversized **Beatbox** BB area paired with the super-stiff and light **Hollowgram Si SL BB30** crank system delivers the torsional rigidity needed to turn the twisting loads from the cranks into blistering speed.

### 2 HOURGLASS REAR STAYS

**Hourglass** stays allow the vertical compliance necessary to maintain confident control over less-than-perfect surfaces, and the comfort required to deliver maximum performance after long days in the saddle.

### 3 DEEP RADIUS HEADTUBE

Deep radius head tube and 1-1/8" to 1.5" tapered carbon steerer fork provide maximum torsional stiffness for precise steering and wicked sprinting. Molded carbon headset cups replace aluminum for weight savings.

## PALMARÉS



2010 Giro d'Italia  
Champion



2010 Tour of California  
Best Young Rider



2010 Tour of California  
Sprinter



2009 Tour de France  
King of the Mountains



### SUPERSIX HI-MOD DI2

**FRAME** SuperSix Hi-MOD, BB30, internal Di2 routing

**FORK** SuperSix, Hi-MOD full carbon, 1-1/8"-1.5" steerer

**WHEELS** Mavic Ksyrium SR

**SHIFTERS** Shimano Di2

**REAR DERAILLEUR** Shimano Di2

**CRANK** Cannondale Hollowgram SL BB30, 53/39 (Includes 50/34 rings and spider)

Matte Carbon, White accents (CRB).

**BRAKES** Shimano Dura-Ace 7900

**TIRES** Schwalbe Ultremo ZX, 700 x 23c

**SIZES** 48, 50, 52, 54, 56, 58, 60, 63cm



### SUPERSIX HI-MOD 1 DURA-ACE

**FRAME** SuperSix Hi-MOD, BB30

**FORK** SuperSix, Hi-MOD full carbon, 1-1/8"-1.5" steerer

**WHEELS** Ksyrium SL, black

**SHIFTERS** Shimano Dura-Ace 7900

**REAR DERAILLEUR** Shimano Dura-Ace 7900

**CRANK** Cannondale Hollowgram SL BB30, 53/39 (Includes 50/34 rings and spider)

Magnesium White, Jet Black (gloss) (WHT).

**BRAKES** Shimano Dura-Ace 7900

**TIRES** Schwalbe Ultremo ZX, 700 x 23c

**SIZES** 48, 50, 52, 54, 56, 58, 60, 63cm



SRAM RED w/Cannondale graphics, BB30, 53/39



**SUPERSIX HI-MOD 2 RED**

Matte Carbon, White accents (CRB).

Magnesium White, Jet Black (gloss) (WHT).

**FRAME** SuperSix Hi-MOD, BB30  
**FORK** SuperSix, Hi-MOD full carbon, 1-1/8"-1.5" steerer  
**WHEELS** Mavic Ksyrium Elite

**SHIFTERS** SRAM RED  
**REAR DERAILLEUR** SRAM RED  
**CRANK** SRAM RED w/Cannondale graphics, BB30, 50/34

**BRAKES** SRAM RED  
**TIRES** Schwalbe Ultrero ZX, 700 x 23c  
**SIZES** 48, 50, 52, 54, 56, 58, 60, 63cm



FSA SL-K Light Carbon BB30, 53/39



### SUPERSIX 1 DURA-ACE

Jet Black Matte w/outline decals (matte) (BLK).

Magnesium White, Race Red (gloss) (RED).

**FRAME** SuperSix Carbon, BB30

**SHIFTERS** Shimano Dura-Ace 7900

**BRAKES** Shimano Ultegra 6700

**FORK** SuperSix, full carbon, 1-1/8"-1.5" steerer, alloy dropouts

**REAR DERAILLEUR** Shimano Dura-Ace 7900

**TIRES** Schwalbe Durano S, 700 x 23c, folding

**WHEELS** Mavic Equipe

**CRANK** FSA SL-K Light Carbon BB30, 50/34

**SIZES** 48, 50, 52, 54, 56, 58, 60, 63cm



FSA SL-K Light Carbon BB30, 53/39



### SUPERSIX 3 ULTEGRA

Race Red (gloss) (RED).

Blue Tinted Clear Coat (gloss) (BLU).

**FRAME** SuperSix Carbon, BB30

**SHIFTERS** Shimano Ultegra 6700

**BRAKES** Tektro R580, dual pivot, cartridge pad

**FORK** SuperSix, full carbon, 1-1/8"-1.5" steerer, alloy dropouts

**REAR DERAILLEUR** Shimano Ultegra 6700

**TIRES** Schwalbe Durano, 700 x 23c, folding

**WHEELS** Mavic Aksium

**CRANK** FSA SL-K Light Carbon BB30, 50/34

**SIZES** 48, 50, 52, 54, 56, 58, 60, 63cm



SRAM Force BB30, 53/39



## SUPERSIX 4 RIVAL

Magnesium White and Orange (gloss) (ORG).

Jet Black Matte w/outline decals (matte) (BLK).

**FRAME** SuperSix Carbon, BB30

**SHIFTERS** SRAM Rival

**BRAKES** SRAM dual pivot

**FORK** SuperSix, full carbon, 1-1/8"-1.5" steerer, alloy dropouts

**REAR DERAILLEUR** SRAM Rival

**TIRES** Schwalbe Durano, 700 x 23c, folding

**WHEELS** Mavic Aksium

**CRANK** SRAM Force BB30, 50/34

**SIZES** 48, 50, 52, 54, 56, 58, 60, 63cm



FSA Gossamer Pro BB30, 53/39



## SUPERSIX 5 105

Exposed Carbon (matte) (CRB).

Team Replica (gloss) (REP).

**FRAME** SuperSix Carbon, BB30

**SHIFTERS** Shimano 105 5700

**BRAKES** Tektro R580, dual pivot, cartridge pad

**FORK** SuperSix, full carbon, 1-1/8"-1.5" steerer, alloy dropouts

**REAR DERAILLEUR** Shimano 105 5700

**TIRES** Schwalbe Lugano, 700 x 23c, folding

**WHEELS** Shimano RS10

**CRANK** FSA Gossamer Pro BB30, 50/34

**SIZES** 48, 50, 52, 54, 56, 58, 60, 63cm

# CAAD10



## CAAD10 1 DURA-ACE

**FRAME** CAAD10, SmartFormed 6069 Alloy, BB30

**FORK** CAAD10, full carbon, 1-1/8"-1-1/4" steerer

**WHEELS** Shimano RS80

**SHIFTERS** Shimano Dura-Ace 7900

**REAR DERAILLEUR** Shimano Dura-Ace 7900

**CRANK** FSA SL-K Light Carbon BB30, 50/34

Black Anodized (matte) (BLA).

Race Red (gloss) (RED).

**BRAKES** Shimano Ultegra 6700

**TIRES** Schwalbe Durano S, 700 x 23c, folding

**SIZES** 48, 50, 52, 54, 56, 58, 60, 63cm



# PERFORMANCE TO THE POWER OF X.

**CAAD10, THE WORLD'S MOST ADVANCED ALUMINUM ROAD FRAME. AT JUST 1150 GRAMS, SIZE 56, IT IS LIGHTER, STIFFER AND SMOOTHER THAN COMPETITORS' ELITE CARBON FRAMES.**



FSA SL-K Light Carbon BB30, 53/39



## **1 SUPERLIGHT CAAD10 FORK**

Housed in our externally machined, tapered head tube, the 390 gram, 1-1/8" to 1-1/4" tapered carbon steerer fork features offset dropouts, allowing more fork angle for vertical compliance without affecting the razor sharp handling

## **2 SAVE REAR STAYS**

Comfort meets acceleration. Rear stays are shaped and butted to allow them to flex vertically but stay extremely stiff laterally. Wide seat stay spacing at top tube junction also improves lateral stiffness.

## **3 OPTIMIZED TOP TUBE**

For maximum torsional rigidity, the massive, horizontally ovalized top tube measures a huge 47.5 x 42 mm where it meets the head tube, narrows through the middle for knee clearance, then widens again to meet the seat stays.



FSA SL-K Light Carbon BB30, 53/39



### CAAD10 3 ULTEGRA

Berserker Green (gloss) (GRN).

Magnesium White (gloss) (WHT).

**FRAME** CAAD10, SmartFormed 6069 Alloy, BB30

**SHIFTERS** Shimano Ultegra 6700

**BRAKES** Tektro R580, dual pivot, cartridge pad

**FORK** CAAD10, full carbon, 1-1/8"-1-1/4" steerer

**REAR DERAILLEUR** Shimano Ultegra 6700

**TIRES** Schwalbe Lugano, 700 x 23c, folding

**WHEELS** Mavic Aksium

**CRANK** FSA SL-K Light Carbon BB30, 50/34

**SIZES** 48, 50, 52, 54, 56, 58, 60, 63cm



SRAM Force BB30, 53/39



### CAAD10 4 RIVAL

Magnesium White, Indigo Blue (gloss) (BLU).

Jet Black, Magnesium White (gloss) (BLK).

**FRAME** CAAD10, SmartFormed 6069 Alloy, BB30

**SHIFTERS** SRAM Rival

**BRAKES** SRAM dual pivot

**FORK** CAAD10, full carbon, 1-1/8"-1-1/4" steerer

**REAR DERAILLEUR** SRAM Rival

**TIRES** Schwalbe Lugano, 700 x 23c, folding

**WHEELS** Shimano RS10

**CRANK** SRAM Force BB30, 50/34

**SIZES** 48, 50, 52, 54, 56, 58, 60, 63cm



Tarsey Anastas - Neovone Studios



FSA Gossamer Pro BB30, 53/39



## CAAD10 5 105

Race Red (gloss) (RED).

Jet Black (gloss) (BLK).

**FRAME** CAAD10, SmartFormed 6069 Alloy, BB30

**SHIFTERS** Shimano 105 5700

**BRAKES** Tektro R580, dual pivot, cartridge pad

**FORK** CAAD10, full carbon, 1-1/8"-1-1/4" steerer

**REAR DERAILLEUR** Shimano 105 5700

**TIRES** Schwalbe Lugano, 700 x 23c, folding

**WHEELS** Shimano RS10

**CRANK** FSA Gossamer Pro BB30, 50/34

**SIZES** 48, 50, 52, 54, 56, 58, 60, 63cm

# CAAD8

## RACE-WINNING PEDIGREE.

THE LIGHTEST FRAME IN ITS CLASS, CAAD8 IS PACKED WITH FEATURES DRAWN DIRECTLY FROM ITS GIRO D'ITALIA-WINNING ANCESTORS. ANDIAMO!

### CANNONDALE ALUMINUM EXPERTISE

With taper-butted, shaped tubes joined by our trademark double pass smooth welds, the CAAD8 continues our tradition of aluminum mastery.

### HEADS-UP RACE GEOMETRY

The CAAD8 shares the proven race geometry of its more expensive brethren but with a slightly taller head tube for a more relaxed riding position.

### HOURLASS SEAT STAYS

The Hourglass shape of the seat stays offers significant vertical compliance for comfort and control over rough surfaces, while remaining laterally rigid for solid power transfer and confident handling.



FSA Gossamer BB30, 50/34

### CAAD8 5 105

**FRAME** CAAD8, Optimized 6061 Alloy, BB30

**FORK** Cannondale Ultra Carbon, carbon blades

**WHEELS** Alex RC24

**SHIFTERS** Shimano 105 5700

**REAR DERAILLEUR** Shimano 105 5700

**CRANK** FSA Gossamer BB30, 50/34

Jet Black (gloss) (BLK).

Magnesium White w/Race Red (gloss) (WHT).

**BRAKES** Tektro R580, dual pivot, cartridge pad

**TIRES** Schwalbe Lugano, 700 x 23c

**SIZES** 48, 51, 54, 56, 58, 61cm



Finalist in *Bicycling* magazine's highly competitive 2010 Editors' Choice Awards in the Entry-Level Road category.



FSA Omega Mega Exo, 50/39/30



## CAAD8 6 TIAGRA

Jet Black (matte) (BBQ).

Magnesium White w/Indigo Blue (gloss) (WHT).

**FRAME** CAAD8, Optimized 6061 Alloy, BB30

**SHIFTERS** Shimano Tiagra

**BRAKES** Cannondale C4 w/cartridge pads

**FORK** Cannondale Ultra Carbon, carbon blades

**REAR DERAILLEUR** Shimano Tiagra

**TIRES** Schwalbe Lugano, 700 x 23c

**WHEELS** Maddux DRX 4000

**CRANK** FSA Omega Mega Exo, 50/34

**SIZES** 48, 51, 54, 56, 58, 61cm



FSA Vero, 50/39/30



## CAAD8 7 SORA

Race Red w/White (gloss) (RED).

Magnesium White w/Charcoal Grey (gloss) (WHT).

**FRAME** CAAD8, Optimized 6061 Alloy, BB30

**SHIFTERS** Shimano Sora

**BRAKES** Cannondale C4 w/cartridge pads

**FORK** Cannondale Ultra Carbon, carbon blades

**REAR DERAILLEUR** Shimano Sora

**TIRES** Schwalbe Lugano, 700 x 23c

**WHEELS** Maddux DRX 4000

**CRANK** FSA Vero, 50/34

**SIZES** 48, 51, 54, 56, 58, 61cm

# SYNAPSE



## SYNAPSE HI-MOD 1 DURA-ACE

**FRAME** Synapse, HI-MOD, SAVE, BB30

**FORK** Synapse, HI-MOD full carbon, SAVE, 1-1/8"

**WHEELS** Mavic Ksyrium SL, black

Exposed Carbon (matte) (CRB).

**SHIFTERS** Shimano Dura-Ace 7900

**REAR DERAILLEUR** Shimano Dura-Ace 7900

**CRANK** Cannondale Hollowgram SL BB30, 50/34

Magnesium White w/Race Red (gloss) (WHT).

**BRAKES** Shimano Dura-Ace 7900

**TIRES** Schwalbe Ultramo ZX, 700 x 25c, folding

**SIZES** 48, 51, 54, 56, 58, 61cm

## GO LONG.

**BUILT FOR THE LONG HAUL AND PERFECTED ON THE COBBLES OF THE NORTHERN CLASSICS, SYNAPSE WON BICYCLING MAGAZINE'S 2010 "BEST PLUSH BIKE" AWARD AND TOP VELO "CYCLOSPORTIF BIKE OF THE YEAR".**



### 1 SAVE MICRO-SUSPENSION SYSTEM

Careful shaping and carbon layup creates a rear stay assembly that is able to deflect vertically, absorbing tremendous amounts of road shock and vibration while staying extremely rigid laterally for power transfer and confident cornering.

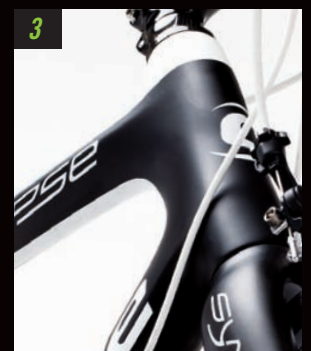

### 2 SAVE FORK BLADES

Full carbon fork from steerer to dropouts with integrated **SAVE** features creates a micro-suspension system that is elegantly simple and doesn't require the additional weight of bumpers or inserts.

### 3 PERFORMANCE GEOMETRY

A taller head tube (2-2.5 cm more than **SuperSix**), a longer wheelbase and relaxed angles produce a more upright riding position and a confidence-inspiring ride which avoids the sluggish feel of many "comfort" road bikes.



### SYNAPSE HI-MOD 2 RED

Magnesium White w/Race Red (gloss) (WHT).

Exposed Carbon (matte) (CRB).

**FRAME** Synapse, Hi-MOD, SAVE, BB30

**SHIFTERS** SRAM RED

**BRAKES** SRAM RED

**FORK** Synapse, Hi-MOD full carbon, SAVE, 1-1/8"

**REAR DERAILLEUR** SRAM RED

**TIRES** Schwalbe Durano 700 x 25c, folding

**WHEELS** Mavic Ksyrium Elite

**CRANK** FSA SL-K Light Carbon BB30, 50/34

**SIZES** 48, 51, 54, 56, 58, 61cm



Bicycling magazine  
2010 Editors' Choice  
Winner "Best Plush Bike"



France's *Top Velo* Issue #5  
named the Synapse Hi-MOD  
"Cyclosportive Bike of the Year!"





FSA SL-K Light Carbon BB30, 52/39/30



### SYNAPSE CARBON 3 ULTEGRA

Race Red w/Magnesium White (gloss) (RED).

**FRAME** Synapse Carbon, SAVE, BB30

**SHIFTERS** Shimano Ultegra 6700

**FORK** Synapse, full carbon, SAVE, alloy dropouts, 1-1/8"

**REAR DERAILLEUR** Shimano Ultegra 6700

**WHEELS** DT Swiss R-1700

**CRANK** FSA SL-K Light Carbon BB30, 50/34

Charcoal Grey w/Magnesium White (gloss) (GRY).

**BRAKES** Shimano Ultegra 6700

**TIRES** Schwalbe Durano, 700 x 25c, folding

**SIZES** 48, 51, 54, 56, 58, 61cm



Indigo Blue (gloss) (BLU).

**FRAME** Synapse Carbon, SAVE, BB30

**SHIFTERS** SRAM Rival

**FORK** Synapse, full carbon, SAVE, alloy dropouts, 1-1/8"

**REAR DERAILLEUR** SRAM Rival

**WHEELS** Mavic Aksium

**CRANK** FSA Gossamer Pro BB30, 50/34

Race Red w/Magnesium White (gloss) (RED).

**BRAKES** SRAM dual pivot

**TIRES** Schwalbe Durano, 700 x 25c, folding

**SIZES** 48, 51, 54, 56, 58, 61cm



### SYNAPSE CARBON 4 RIVAL



FSA Gossamer Pro BB30,  
52/39/30



## SYNAPSE CARBON 5 105

Berserker Green (gloss) (GRN).

Jet Black (gloss) (BLK).

**FRAME** Synapse Carbon, SAVE, BB30

**SHIFTERS** Shimano 105 570

**BRAKES** Tektro R580, dual pivot, cartridge pad

**FORK** Synapse, full carbon, SAVE, alloy dropouts, 1-1/8"

**REAR DERAILLEUR** Shimano 105 5700

**TIRES** Schwalbe Lugano, 700 x 25c, folding

**WHEELS** Shimano RS10

**CRANK** FSA Gossamer Pro BB30, 50/34

**SIZES** 48, 51, 54, 56, 58, 61cm



Charcoal Grey (matte) (GRY).

Indigo Blue (gloss) (BLU).

## SYNAPSE CARBON 6 APEX

**FRAME** Synapse Carbon, SAVE

**SHIFTERS** SRAM Apex

**BRAKES** SRAM Apex

**FORK** Synapse, full carbon, SAVE, alloy dropouts, 1-1/8"

**REAR DERAILLEUR** SRAM Apex WiFLi

**TIRES** Schwalbe Lugano, 700 x 25c, folding

**WHEELS** Shimano R500A

**CRANK** SRAM S150 Compact, 50/34

**SIZES** 48, 51, 54, 56, 58, 61cm



FSA Gossamer BB30, 50/39/30



## SYNAPSE ALLOY 5 105

Magnesium White w/Indigo Blue (gloss) (WHT).

Jet Black w/White (gloss) (BLK).

**FRAME** Synapse, Optimized 6061 alloy, SAVE, BB30

**SHIFTERS** Shimano 105 5700

**BRAKES** Tektro 580, long reach, dual pivot, cartridge pad

**FORK** Synapse, SAVE, carbon blades, 1-1/8"

**REAR DERAILLEUR** Shimano 105 5700

**TIRES** Schwalbe Lugano, 700 x 25c

**WHEELS** Shimano RS10

**CRANK** FSA Gossamer BB30, 50/34

**SIZES** 48, 51, 54, 56, 58, 61cm



FSA Omega Mega Exo, 50/39/30



## SYNAPSE ALLOY 6 TIAGRA

Indigo Blue w/White (gloss) (BLU).

Magnesium White w/Race Red (gloss) (WHT).

**FRAME** Synapse, Optimized 6061 alloy, SAVE

**SHIFTERS** Shimano Tiagra

**BRAKES** Cannondale C4, long reach, dual pivot, cartridge pad

**FORK** Synapse, SAVE, carbon blades, 1-1/8"

**REAR DERAILLEUR** Shimano Tiagra

**TIRES** Schwalbe Lugano, 700 x 25c

**WHEELS** Maddux DRX 4000

**CRANK** FSA Omega MegaExo, 50/34

**SIZES** 48, 51, 54, 56, 58, 61cm



## SYNAPSE ALLOY 7 SORA

Race Red w/White (gloss) (RED).

Jet Black w/White (gloss) (BLK).

**FRAME** Synapse, Optimized 6061 alloy, SAVE

**SHIFTERS** Shimano Sora

**BRAKES** Cannondale C4, long reach, dual pivot, cartridge pad

**FORK** Synapse, SAVE, carbon blades, 1-1/8"

**REAR DERAILLEUR** Shimano Sora

**TIRES** Schwalbe Lugano, 700 x 25c

**WHEELS** Maddux DRX 4000

**CRANK** FSA Vero, 50/39/30

**SIZES** 48, 51, 54, 56, 58, 61cm

# SLICE

**FIND YOUR NEW FAST.**

**THE QUEEN K. THE LAVA FIELDS. ALI'I DRIVE AND PALANI. WORLD RECORDS AND THE GIRO D'ITALIA. SLICE'D. AND DICED.**

## LIGHTEST AERO FRAME

Unmatched in stiffness-to-weight, the 1290 grams Hi-MOD is the world's lightest production aero frame. Sick of aero bikes that don't climb? Get on a Slice.

## RIDE SMOOTHER. RUN FRESHER

Aerodynamics aren't worth a thing if you can't maintain the aero position or are too beat up to run. Slice's SAVE rear stay micro-suspension system deflects vertically to absorb road shock while staying extremely stiff laterally and torsionally.

## SUPERB GEOMETRY

Tired of nervous, twitchy-handling aero bikes? The Slice descends as well as it climbs. The refined geometry and a two-position aero seatpost enable riders to find their perfect aero position. Stable, neutral handling and SAVE features help them maintain it.



## SLICE HI-MOD SRAM RED

**FRAME** Slice, Hi-MOD, SAVE, BB30

**FORK** Slice Aero, Hi-MOD full carbon

**WHEELS** Mavic Cosmic Carbone SL

**SHIFTERS** SRAM 1090 R2C

**REAR DERAILLEUR** SRAM RED

**CRANK** Cannondale Hollowgram SL BB30, 53/39 w/Aero Spider and SRAM TT rings

**BRAKES** SRAM RED

**TIRES** Schwalbe Ultremo ZX, 700 x 23c

**SIZES** 51, 54, 56, 58, 60cm

Jet Black (matte) (BBQ).



Eric Wynn

## PALMARÉS



2009 Ironman World  
Champion, World  
Championship Record Holder,  
"World's Best" Record Holder  
- Ironman Distance



2007 Ironman 70.3  
World Champion



### SLICE 3 ULTEGRA

Magnesium White (gloss) (WHT).

**FRAME** Slice Carbon, SAVE, BB30

**SHIFTERS** Shimano Ultegra 6700

**BRAKES** Shimano Ultegra 6700

**FORK** Slice Aero, full carbon

**REAR DERAILLEUR** Shimano Ultegra 6700

**TIRES** Schwalbe Durano S, 700 x 23c, folding

**WHEELS** Mavic Cosmic Elite

**CRANK** Vision TriMax Carbon TT BB30, 53/39

**SIZES** 51, 54, 56, 58, 60cm



### SLICE 4 RIVAL

Magnesium White (gloss) (WHT).

**FRAME** Slice Carbon, SAVE, BB30

**SHIFTERS** SRAM 1090 R2C

**BRAKES** SRAM Dual Pivot

**FORK** Slice Aero, full carbon

**REAR DERAILLEUR** SRAM Rival

**TIRES** Schwalbe Lugano, 700 x 23c, folding

**WHEELS** Fulcrum Racing 7

**CRANK** FSA Trimax Pro BB30, 52/38

**SIZES** 51, 54, 56, 58, 60cm



Bettini



## SLICE 5 105

Magnesium White (gloss) (WHT).

**FRAME** Slice Carbon, SAVE, BB30

**SHIFTERS** Microshift Shimano-compatible bar-end

**BRAKES** Tektro R520

**FORK** Slice Aero, full carbon

**REAR DERAILLEUR** Shimano 105 5700

**TIRES** Schwalbe Lugano, 700 x 23c, folding

**WHEELS** Shimano R500A

**CRANK** FSA Gossamer Pro BB30, 53/39

**SIZES** 51, 54, 56, 58, 60cm

# SUPERX



## SUPERX SRAM RED

**FRAME** SuperX, BallisTec Hi-MOD carbon, SAVE, BB30

**FORK** SuperX, BallisTec Hi-MOD carbon, 1-1/8" to 1-1/4"

**WHEELS** ZIPP 303 Cyclocross Tubular

**SHIFTERS** SRAM RED

**REAR DERAILLEUR** SRAM RED

**CRANK** Cannondale Hollowgram SL BB30, 46/36

**BRAKES** FSA SLX

**TIRES** Vittoria EVO XM Cross Tubular

**SIZES** 44, 48, 52, 54, 56, 58cm

Berserker Green (gloss) (GRN).



## ***SHEER AND UTTER DOMINANCE.***

***BLENDING THE CARBON TECHNOLOGY OF OUR FLASH WITH THE RACE PROVEN GEOMETRY OF THE CAAD9 CROSS, SUPERX IS A RECIPE FOR DOMINATION. THIS SEASON'S FORECAST: IT'S GONNA REIGN.***



**1 BALLISTEC CARBON FIBER**  
SuperX is crafted from BallisTec carbon fiber. Developed for ballistic armoring, this allows SuperX to shrug off rock impacts that would cripple other carbon frames.

**2 SAVE REAR MICRO-SUSPENSION SYSTEM**  
SAVE rear stays with flattened cross-sections and sophisticated carbon layup act as a micro-suspension system, keeping you in control and fresh on the most rugged winter courses.

**3 OVERSIZED HEAD TUBE**  
Tapered, oversized head tube houses a 1-1/8" to 1-1/4" tapered carbon steerer fork for maximum strength and steering precision.



### PALMARÉS



2009 Italian National Champion



2009 US National Champion



2007 US National Champion

### SUPERX SRAM RIVAL

Berserker Green (gloss) (GRN).

**FRAME** SuperX, BallisTec Hi-MOD carbon, SAVE, BB30

**SHIFTERS** SRAM Rival

**BRAKES** FSA SLK

**FORK** SuperX, BallisTec Hi-MOD carbon, 1-1/8" to 1-1/4"

**REAR DERAILLEUR** SRAM Rival

**TIRES** Continental CX RACE, 700 X 35c

**WHEELS** Mavic Ksyrium Equipe

**CRANK** FSA SL-K Light Carbon BB30, 46/36

**SIZES** 44, 48, 52, 54, 56, 58cm

# CAADX

## HEED THE CALL.

WHETHER JUMPING INTO THE FALL MADNESS OF CYCLOCROSS OR SIMPLY LOOKING FOR A SUPREMELY VERSATILE BIKE FOR TRAINING, COMMUTING OR ADVENTURING, THE CAADX CYCLOCROSS BIKE IS THE PERFECT CHOICE.

### HEADS-UP RACE GEOMETRY

The CAADX has a slightly taller head tube and slightly slacker head tube angle than the SuperX, providing a more upright position and super stable handling.

### CANNONDALE ALUMINUM EXPERTISE

With taper-butted, shaped tubes joined by our trademark double pass smooth welds, CAADX continues our tradition of aluminum mastery.

### HOURLASS STAYS

The hourglass shape of the seat stays offers significant vertical compliance for key comfort and control over the harsh ruts and mud of 'cross, while remaining laterally rigid for solid power transfer and confident handling.



### CAADX SRAM RIVAL

**FRAME** CAADX Cyclocross, Optimized 6061 alloy, BB30

**FORK** Cannondale Ultra X, carbon blades, 1-1/8"

**WHEELS** Maddux DRX 6000

**SHIFTERS** SRAM Rival

**REAR DERAILLEUR** SRAM Rival

**CRANK** FSA Gossamer Pro BB30, 46/36

**BRAKES** TRP EuroX

**TIRES** Continental Cyclocross Speed, 700 x 35c

**SIZES** 44, 48, 51, 54, 56, 58, 61cm

Race Red (gloss) (RED).



## CAADX 105

Brushed Aluminum (RAW).

**FRAME** CAADX Cyclocross, Optimized 6061 alloy, BB30

**SHIFTERS** Shimano 105 5700

**BRAKES** Tektro CR720

**FORK** Cannondale Ultra X, carbon blades, 1-1/8"

**REAR DERAILLEUR** Shimano 105 5700

**TIRES** Continental Cyclocross Speed, 700 x 35c

**WHEELS** Maddux DRX 6000

**CRANK** FSA Gossamer BB30, 46/36

**SIZES** 44, 48, 51, 54, 56, 58, 61cm



## CAADX TIAGRA

Jet Black (matte) (BBQ).

**FRAME** CAADX Cyclocross, Optimized 6061 alloy, BB30

**SHIFTERS** Shimano Tiagra

**BRAKES** Tektro CR520

**FORK** Cannondale Ultra X, carbon blades, 1-1/8"

**REAR DERAILLEUR** Shimano Tiagra

**TIRES** Continental Cyclocross Speed, 700 x 35c

**WHEELS** Maddux DRX 6000

**CRANK** FSA Omega Mega Exo, 46/36

**SIZES** 44, 48, 51, 54, 56, 58, 61cm



FSA Omega Mega Exo, 50/39/30

# HELPING THE PLANET HELP ITSELF.

## RIDE A BIKE. ANY BIKE.

*For errands. For exercise. For fun. An oft-quoted fact is that 40% of all trips from home are less than 2 miles and 90% of them are made by car. Replacing one of these trips by bike is an easy start. Pick your route to work, to school, to the gym or to the grocery store. Or consider ditching the gym and riding outside in the summer. The benefits soon pile up: from rediscovering your neighborhood and the freedom of your childhood bike rides, to being active, getting fitter, spending less on gas and unhitching yourself from a car-only mentality.*

*We encourage you to ride a bike, any bike, and to help us support others who do the same.*

### SUPPORTING PEOPLE FOR BIKES

Imagine one million people signing a petition in support of a better future for bicycling in the United States. We've partnered with People for Bikes to make that happen. By sending a unified message to our elected leaders, the media and the public, we can tell them that bicycling is important. With your help, we can ensure that our sport is properly promoted, funded and supported. More rider friendly communities, bike lanes and bike paths equal safety and fitness for all of us. Sign the pledge today at <http://www.peopleforbikes.org/>

### SUPPORTING BIKES BELONG

We're supporting Bikes Belong and its mission to get more people riding bicycles. Since 1999, they've focused their efforts on advocating for more funding for new bicycle facilities that would increase bike riding, boost public health and strengthen the bike business. Their goal: creating safe places to ride so more people will bike, and bike more often. Learn more at: <http://www.bikesbelong.org/>

### SUPPORTING IMBA (INTERNATIONAL MOUNTAIN BIKE ASSOCIATION)

Cannondale's support of IMBA helps ensure that mountain bikers everywhere continue to have the land access rights, quality trails, and commitment to advocacy that makes the sport truly fun and enjoyable. Cannondale was one of the first sponsors of IMBA in 1991 and is proud to continue its support of the organization. What would you do without trails? <http://www.imba.com/>



@ridecannondale



facebook.com/ridecannondale



www.cannondale.com

**RECREATION / URBAN**

QUICK	78-81
QUICK CX	82-83
ADVENTURE	84-85
BAD BOY	86-88
TANDEM	89
HOOLIGAN	90-91

# RECREATION/URBAN



GO  
TIME.

# QUICK

**QUICK: YOU'VE ARRIVED.**

**WHETHER SPEEDING DOWN THE WEST SIDE BIKE PATH OR CRUISING A WEST COAST CHARITY RIDE, QUICK IS A GORGEOUS EXPRESSION OF SPEED IN A LUXURIOUS WRAPPING OF STYLE.**

## FLAT BARS RULE

With stunning styling and ride-all-day performance, **Quick** proves that speed, style and performance aren't exclusive to the drop bar crowd.

## VIBRATION DAMPING STAYS

Optimized chain stay and seat stay shaping provides bump absorption, comfort and enhanced control with no loss in power transfer.

## LIGHT AND STYLISH

Whether the **Quick**, the lighter **Quick SL** or the radical **Quick Carbon**, these sleekly-styled frames are the lightest in class, making the bike nimble, responsive and a breeze to carry up stairs.



## QUICK CARBON 1

Uni-directional Carbon (matte) (CRB).

**FRAME** Quick, full carbon, BB30

**SHIFTERS** Shimano SL-R770

**BRAKES** Tektro Mini-V w/cartridge pads

**FORK** Quick, full carbon, Si

**REAR DERAILLEUR** Shimano Ultegra 6700, 10-speed

**TIRES** Kenda Kwick Roller Sport, 700 X 28c

**WHEELS** Formula XERO Element CXR

**CRANK** FSA SLK BB30 Compact, 50/34

**SIZES** S, M, L, X, J





Chris Milliman



## QUICK CARBON 2

**FRAME** Quick, full carbon, BB30

**FORK** Quick, full carbon, Si

**WHEELS** Formula XERO Element CXR

**SHIFTERS** Shimano SL-R770

**REAR DERAILLEUR** Shimano 105 5700, 10-speed

**CRANK** FSA Gossamer BB30 Triple, 52/39/30

Uni-directional Carbon (matte) (CRB).

**BRAKES** Tektro Mini-V w/cartridge pads

**TIRES** Kenda Kwick Roller Sport, 700 X 28c

**SIZES** S, M, L, X, J



### QUICK 1

Brushed Aluminum (gloss) (RAW).

**FRAME** Quick SL, Optimized 6061 alloy, SAVE

**SHIFTERS** Shimano SL-R770

**BRAKES** Tektro RX5 Mini V-Brakes

**FORK** Quick, carbon blades, 1-1/8" steerer

**REAR DERAILLEUR** Shimano 105 5700, 10-speed

**TIRES** Continental Sport Contact, 700 x 32c

**WHEELS** Element Xero C2

**CRANK** Shimano 105 5700 triple, 50/39/30

**SIZES** S, M, L, X, J



### QUICK 2

Jet Black (gloss) (BLK).

**FRAME** Quick SL, Optimized 6061 alloy, SAVE

**SHIFTERS** Shimano SL-R440

**BRAKES** Tektro RX5 Mini V-Brakes

**FORK** Quick, carbon blades, 1-1/8" steerer

**REAR DERAILLEUR** Shimano Tiagra, 9-speed

**TIRES** Continental Sport Contact, 700 x 32c

**WHEELS** Element Xero C3

**CRANK** Shimano Tiagra triple, 50/39/30

**SIZES** XS (26"), S, M, L, X, J



### QUICK 3

**FRAME** Quick SL, Optimized 6061 alloy, SAVE

**FORK** Quick, carbon blades, 1-1/8" steerer

**WHEELS** Element Xero C3

Indigo Blue (gloss) (BLU).

**SHIFTERS** Shimano Alivio

**REAR DERAILLEUR** Shimano Deore, 9-speed

**CRANK** Shimano M431, 48/36/26



Magnesium White (gloss) (WHT).

**BRAKES** Tektro RX1 Mini V-Brakes

**TIRES** Continental City Contact, 700 x 32c

**SIZES** S, M, L, X, J



### QUICK 4

**FRAME** Quick, double butted 6061 alloy, SAVE

**FORK** Quick, carbon blades, 1-1/8" steerer

**WHEELS** Element Xero C3

Charcoal Grey (gloss) (GRY).

**SHIFTERS** Shimano Alivio

**REAR DERAILLEUR** Shimano Alivio, 8-speed

**CRANK** Shimano M131, 48/38/28



Jet Black (gloss) (BLK).

**BRAKES** Tektro TX 120 V-Brakes

**TIRES** Kenda Kwick Trax, 700 X 38c

**SIZES** XS (26"), S, M, L, X, J



### QUICK 5

**FRAME** Quick CX, Optimized 6061 alloy, SAVE

**FORK** Quick 6061 Alloy

**WHEELS** Jalco DT 21

Fine Silver (gloss) (SLV).

**SHIFTERS** Shimano Altus

**REAR DERAILLEUR** Shimano Altus, 8-speed

**CRANK** Shimano M131, 48/38/28



Goodnight Green (matte) (GRN).

**BRAKES** Tektro TX 120 V-Brakes

**TIRES** Kenda Kwick Trax, 700 X 38c

**SIZES** S, M, L, X, J

# QUICK CX

**STYLISH AND RUGGED. SLEEK AND DURABLE.**

**QUICK CX IS A BEAUTIFUL CONTRADICTION, OFFERING MOUNTAIN BIKE STABILITY AND CITY BIKE NIMBLENESS IN ONE PACKAGE - PERFECT FOR VENTURING OFF THE BEATEN PATH.**

## TRAVEL IN STYLE

Sleek, functional tube shapes make a statement on the streets but are up to the challenge of excursions on rougher roads and bike trails.

## VIBRATION DAMPING STAYS

Optimized chain stay and seat stay shaping provides bump absorption, comfort and enhanced control with no loss in power transfer.

## HEADS-UP RIDING

Quick CX geometry delivers an upright riding position for increased comfort, visibility and enjoyment. Relax and enjoy the ride.



## QUICK CX 1

**FRAME** Quick CX HeadShok, Optimized 6061 alloy, SAVE

**FORK** HeadShok Fatty DL50 w/Lock Out

**WHEELS** Maddux Disc X320 w/eyelets

**SHIFTERS** Shimano Deore

**REAR DERAILLEUR** Shimano SLX, 9-speed

**CRANK** Shimano M521, 48/36/26

Brushed Aluminum (gloss) (RAW).

**BRAKES** Shimano M505 Hydraulic Disc

**TIRES** Continental Double Fighter II, 700 x 37c

**SIZES** S, M, L, X, J



### QUICK CX 2

Race Red (gloss) (RED).

**FRAME** Quick CX, Optimized 6061 alloy, SAVE

**SHIFTERS** Shimano Alivio

**BRAKES** Shimano M445 hydraulic disc

**FORK** RST Neon Pro Custom 1.5" Trekking TnL Lockout, 50 mm

**REAR DERAILLEUR** Shimano Deore, 9-speed

**TIRES** Continental Double Fighter II, 700 x 37c

**WHEELS** Maddux Disc X320 w/eyelets

**CRANK** Shimano M431, 48/36/26

**SIZES** S, M, L, X, J



### QUICK CX 3

Lightning White (gloss) (WHT).

**FRAME** Quick CX, Optimized 6061 alloy, SAVE

**SHIFTERS** Shimano Acera

**BRAKES** Tektro Novela mechanical disc

**FORK** RST Neon Pro Custom 1.5" Trekking ML Lockout, 50 mm

**REAR DERAILLEUR** Shimano Alivio, 8-speed

**TIRES** Continental Double Fighter II, 700 x 37c

**WHEELS** Maddux Disc X320 w/eyelets

**CRANK** Shimano M171, 48/38/28

**SIZES** S, M, L, X, J



### QUICK CX 4

Jet Black (gloss) (BLK).

**FRAME** Quick CX, Optimized 6061 alloy, SAVE

**SHIFTERS** Shimano Altus

**BRAKES** Tektro Novela mechanical disc

**FORK** Fatty Rigid Disc

**REAR DERAILLEUR** Shimano Acera, 8-speed

**TIRES** Continental Double Fighter II, 700 x 37c

**WHEELS** Maddux Disc X320 w/eyelets

**CRANK** Shimano M171, 48/38/28

**SIZES** S, M, L, X, J

# ADVENTURE

**LUXURIOUS, FAST AND FRIENDLY.**

**COMMUTING ONE DAY, RUNNING ERRANDS  
THE NEXT, BIKING WITH THE KIDS OR  
TAKING A SPIN ON A WEEKEND GETAWAY,  
ADVENTURE IS READY TO HANDLE IT ALL.**

## **RIDER-TAILORED GEOMETRY**

**Adventure** has our most upright rider position, aimed at maximum comfort without being sluggish. We also ensure that at the correct seat height you can still touch the ground comfortably without losing the ability to ride efficiently.

## **LUXURIOUS TRAPPINGS**

Soft touch grips and quick release levers combined with a super plush sprung saddle give the **Adventure** a luxurious feel.

## **TOOL-FREE STEM ADJUSTMENT**

Rider position customizes easily with a quick and secure lever-action adjustable stem.



## **ADVENTURE 1**

Jet Black (gloss) (BLK).

**FRAME** Adventure, double butted 6061 alloy

**SHIFTERS** Shimano Nexus, twist type

**BRAKES** Cannondale V Brake w/modulator

**FORK** Adventure Trail Si suspension, alloy, 35 mm

**REAR HUB** Shimano Nexus Premium 8-speed internal rear

**TIRES** Kenda Kwick Trax, 700 x 38c

**WHEELS** Cannondale C3, double wall, alloy

**CRANK** FSA Single Ring, 38

**SIZES** S, M, L, X, J



### ADVENTURE 2

Indigo Blue (gloss) (BLU).

Charcoal Gray (gloss) (GRY).

**FRAME** Adventure, double butted 6061 alloy

**SHIFTERS** Shimano Revo, twist type

**BRAKES** Cannondale V Brake w/modulator

**FORK** Adventure Trail Si suspension, steel, 35 mm

**REAR DERAILLEUR** Shimano Alivio, 8-speed

**TIRES** Kenda Kwick Trax, 700 x 38c

**WHEELS** Cannondale C3, double wall, alloy

**CRANK** Shimano M191, 48/38/28

**SIZES** S, M, L, X, J



### ADVENTURE 3

Jet Black (gloss) (BLK).

Goodnight Green (gloss) (GRN).

**FRAME** Adventure, double butted 6061 alloy

**SHIFTERS** Shimano Revo, twist type

**BRAKES** Cannondale V Brake w/modulator

**FORK** RST Sofi T, 50 mm

**REAR DERAILLEUR** Shimano Acera, 8-speed

**TIRES** Kenda Kwick Trax, 700 x 38c

**WHEELS** Cannondale C3, double wall, alloy

**CRANK** Shimano M191, 48/38/28

**SIZES** S, M, L, X, J



### ADVENTURE 3-26"

Goodnight Green (gloss) (GRN).

Jet Black (gloss) (BLK).

**FRAME** Adventure, double butted 6061 alloy, for 26" wheels

**SHIFTERS** Shimano Revo, twist type

**BRAKES** Cannondale V Brake w/modulator

**FORK** RST Sofi T 26", 50 mm

**REAR DERAILLEUR** Shimano Acera, 8-speed

**TIRES** Kenda NPJ signature, 26 x 1.25"

**WHEELS** Cannondale C3, double wall, alloy, 26"

**CRANK** Shimano M191, 48/38/28

**SIZES** S, M, L, X, J

# BAD BOY



## BAD BOY SOLO HEADSHOK

Jet Black (matte) (BBQ).

**FRAME** Bad Boy Stealth, Optimized 6061 alloy, HeadShok

**SHIFTERS** Shimano Deore

**BRAKES** Shimano M505 hydraulic disc

**FORK** HeadShok Solo DL50, OPI

**REAR DERAILLEUR** Shimano SLX, 9-speed

**TIRES** Schwalbe Kojak Race Guard, 700 x 28c

**WHEELS** Maddux SR300

**CRANK** Shimano M431, 48/36/26 Custom Bad Boy

**SIZES** S, M, L, X



# THE PERFECT ANTI-BLING STATEMENT.

AT HOME UNDER THE LIGHTS OF AN UPTOWN ART STUDIO OR CHAINED UP OUTSIDE A DOWNTOWN DIVE BAR. STEALTH FIGHTER-INSPIRED. FLY UNDER THE RADAR.

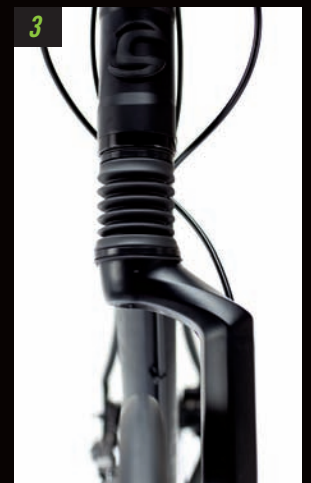

## 1 STYLISH INTEGRATION

True to the Bad Boy ethos and style, the handlebar and stem are 3D forged into one piece using our OPI technology.

## 2 SAVE STAYS

Optimized chain stay shaping provides lateral rigidity while providing bump absorption and comfort. Ease the sting of the rough city streets without any loss in power transfer.

## 3 BAD-ASS FORK OPTIONS

Bad Boy is available with the radical single-legged **HeadShok Solo DL50** with 50 mm of travel, hydraulic damping and lockout. Other models feature **Solo** rigid or **Fatty** rigid.



## BAD BOY SOLO

Jet Black (matte) (BBQ).

<b>FRAME</b> Bad Boy Urban, Optimized 6061 alloy	<b>SHIFTERS</b> Shimano Deore	<b>BRAKES</b> Shimano M445 hydraulic disc
<b>FORK</b> Cannondale Solo DL50, OPI, 1-1/8"	<b>REAR DERAILLEUR</b> Shimano Deore, 9-speed	<b>TIRES</b> Schwalbe Kojak Race Guard, 700 x 28c
<b>WHEELS</b> Maddux SR300	<b>CRANK</b> Shimano M431, 48/36/26 Custom Bad Boy	<b>SIZES</b> S, M, L, X



## BAD BOY

Jet Black (matte) (BBQ).

<b>FRAME</b> Bad Boy Urban, Optimized 6061 alloy	<b>SHIFTERS</b> Shimano Altus	<b>BRAKES</b> Tektro Novela mechanical disc
<b>FORK</b> Cannondale Fatty Rigid, 1-1/8"	<b>REAR DERAILLEUR</b> Shimano Alivio, 8-speed	<b>TIRES</b> Schwalbe Kojak Race Guard, 700 x 28c
<b>WHEELS</b> Maddux SR300	<b>CRANK</b> Shimano M361, 48/38/28 Custom Bad Boy	<b>SIZES</b> S, M, L, X

# TANDEM

**DOUBLE THE FUN. DOUBLE THE THRILL.**

**MORE POWER. MORE SPEED. MORE THRILLS AND COMPANY TO BOOT. TWO IS THE MAGIC NUMBER.**

## LIGHTEST AND STIFFEST

It's the lightest, most torsionally rigid tandem on the market. No squirrely flex when powering out of the saddle. Responsive handling and sure-footed tracking when bombing the descents. Pure speed, pure confidence, pure performance.

## OPTIMIZED COCKPITS

A taller head tube and shorter top tube give the captain better control and more comfort while the stoker gets increased stand over clearance.

## CANNONDALE ALUMINUM

A structure as long as a tandem is the perfect challenge for our aluminum skills. The box section **Boom Tube**, oversized chain stays and dropouts and smooth welds showcase our expertise.



## ROAD TANDEM 2

Lightning White (gloss) (WHT).

**FRAME** CAAD Tandem, Optimized 6061 alloy, 700c

**SHIFTERS** Shimano Ultegra 6700

**BRAKES** Avid BB7 Road Disc

**FORK** Fatty R Tandem rigid

**REAR DERAILLEUR** Shimano Ultegra 6700, 10-speed

**TIRES** Continental Ultra GatorSkin, 700 x 28c

**WHEELS** Sun ME14A w/eyelet and machined sidewall, 40 hole

**CRANK** FSA Gossamer Tandem, 53/39/30

**SIZES** MS, LS, XS, JM

# HOOOLIGAN

## ART ON WHEELS.

**RULE THE URBAN JUNGLE. POUND CITY  
POTHOLE. HOP CURBS AND OBSTACLES.  
FLATLAND. HOOOLIGAN DOES IT ALL.**

### 20" WHEELS

20" wheels accelerate faster and make **Hooligan** a compact, easily stored bike for those small city apartments.

### ONE SIZE FITS ALL

The low standover, custom seatpost and adjustable stem allow **Hooligan** to accommodate all sizes of rider and all styles of riding, from upright and comfy to dropped and aggressive.

### DELTA V FRAME

For the types of riding the **Hooligan** might encounter, our **Delta V** frame configuration has proven to be the lightest and strongest, while the improved standover allows plenty of clearance for agile street moves.



### HOOOLIGAN 3

Jet Black (matte) (BBQ).

Magnesium White (gloss) (WHT).

**FRAME** Hooligan Delta V, Urban Compact, 6061 alloy, 20" wheel

**SHIFTERS** SRAM I Motion, 3-speed

**BRAKES** AVID BB5, mechanical disc

**FORK** Cannondale Solo Rigid

**REAR HUB** SRAM I Motion, 3-speed

**TIRES** Schwalbe Kojak 1.35" race guard

**WHEELS** Jalco X320 Disc, 20"

**CRANK** FSA Vero Double Bash Guard, RED anodized 42

**SIZES** One Size



John Segesta



## HOOLIGAN 8

Magnesium White (gloss) (WHT).

**FRAME** Hooligan Delta V, Urban Compact, 6061 alloy, 20" wheel

**SHIFTERS** Shimano Alivio

**BRAKES** Tektro Novela Mechanical Disc

**FORK** Cannondale Fatty Rigid

**REAR DERAILLEUR** Shimano 2300, 8-speed

**TIRES** Kenda Kwest 1.5"

**WHEELS** Jalco X320 Disc, 20"

**CRANK** FSA Tempo Double Bash Guard 42

**SIZES** One Size

	<b>CLAYMORE 1</b>	<b>CLAYMORE 2</b>	<b>CLAYMORE 3</b>	<b>JEKYLL ULTIMATE</b>	<b>JEKYLL CARBON 1</b>
<b>Code</b>	1VA1	1VA2	1VA3	1VNO	1VNI
<b>Frame</b>	Claymore, 180/110 mm, SmartFormed alloy, BB30, ISCG03, Diablo 1.5 Si head tube	Claymore, 180/110 mm, SmartFormed alloy, BB30, ISCG03, Diablo 1.5 Si head tube	Claymore, 180/110 mm, SmartFormed alloy, BB30, ISCG03, Diablo 1.5 Si head tube	JeKyll, 150/90 mm, BallisTec Hi-MOD Carbon, BB30, ISCG03, 1.5 Si head tube	JeKyll, 150/90 mm, BallisTec Hi-MOD Carbon, BB30, ISCG03, 1.5 Si head tube
<b>Fork</b>	Fox 36 Talas RC2 FIT, 180 mm, 20QR thru axle, 1.5"	Fox 36 Talas R, 180 mm, 20QR thru axle, 1.5"	Fox 36 Talas R, 180 mm, 20QR thru axle, 1.5"	Fox 32 Talas RLC FIT, 150 mm, 15QR thru axle, 1.5"	Fox 32 Talas RLC FIT, 150 mm, 15QR thru axle, 1.5"
<b>Rear Shock</b>	Fox DYAD RT2 dual shock 180/110 mm	Fox DYAD RT2 dual shock 180/110 mm	Fox DYAD RT2 dual shock 180/110 mm	Fox DYAD RT2 dual shock 150/90 mm	Fox DYAD RT2 dual shock 150/90 mm
<b>Rims</b>	Mavic CrossMax SX, tubeless	SunRingle Charger Pro, tubeless ready	Sun EQ27, 32 hole	CrankBrothers Cobalt, tubeless	SunRingle BlackFlag Pro, tubeless ready
<b>Hubs</b>	Mavic CrossMax SX, 20 mm front, 142 x 12 mm rear	SunRingle Charger Pro, 20 mm front, 142 x 12 mm rear	Formula, 32 hole, thru20 front, 142 x 12 mm rear	CrankBrothers Cobalt, 15 mm front, 142 x 12 mm rear	SunRingle BlackFlag Pro, 24 hole, 15 mm front, 142 x 12 mm rear
<b>Spokes</b>	Mavic CrossMax SX	SunRingle Charger Pro	DT Swiss Champion BLK 1.8 mm	CrankBrothers Cobalt	SunRingle BlackFlag Pro
<b>Tires</b>	Schwalbe Fat Albert Pace/TrailStar, 2.4" tubeless ready	Schwalbe Fat Albert Pace/TrailStar, 2.4" tubeless ready	Kenda Nevegal folding, 2.35	Schwalbe Nobby Nic PaceStar, 2.4" tubeless ready	Schwalbe Nobby Nic PaceStar, 2.4" tubeless ready
<b>Pedals</b>	N/A	N/A	N/A	N/A	N/A
<b>Crank</b>	SRAM S1400, BB30, 39/26	SRAM S1400, BB30, 39/26	TruVativ Fire-X AM 36/24 2.2	Cannondale Hollowgram SL, BB30, 39/26	FSA SL-K BB30, 44/32/24
<b>Bottom Bracket</b>	SRAM, BB30	SRAM, BB30	Included	Cannondale BB30	FSA BB30
<b>Chain</b>	KMC X10SL, 10-speed	Shimano HG74, 10-speed	KMC X10, 10-speed	KMC X10SL, 10-speed	Shimano HG74, 10-speed
<b>Rear Cogs</b>	Shimano XT, 11-36, 10-speed	Shimano SLX, 11-36, 10-speed	Shimano SLX, 11-36, 10-speed	SRAM XX, 11-36, 10-speed	Shimano XT, 11-36, 10-speed
<b>Front Derailleur</b>	Shimano SLX	Shimano SLX	Shimano SLX	SRAM XX	Shimano XT
<b>Rear Derailleur</b>	SRAM X0	Shimano XT	SRAM X9	SRAM XX	Shimano XTR
<b>Shifters</b>	SRAM X9	Shimano SLX	SRAM X7	SRAM XX	Shimano XT
<b>Handlebar</b>	Syntaxe Vector 680 mm, zero rise, carbon	Cannondale C2 riser, 680 x 20 mm, 2014 alloy	Cannondale C2 riser, 680 x 20 mm, 2014 alloy	Syntaxe Vector, 680 x 0 mm, zero rise, carbon	FSA SL-K riser, 680 x 18 mm
<b>Stem</b>	Syntaxe Force, 1.5", 31.8	Cannondale C3, 1.5", 31.8	Cannondale C3 1.5", 31.8	Syntaxe Force 1.5", 31.8"	Cannondale C2 1.5", 31.8
<b>Headset</b>	Tange Seiki 1.5", Integrated	Tange Seiki 1.5", Integrated	Tange Seiki 1.5", Integrated	Tange Seiki 1.5", Integrated	Tange Seiki 1.5", Integrated
<b>Brakes</b>	Avid Elixir X0 carbon, 203/185 mm	Avid Elixir CR, 203/185 mm	Avid Elixir R, 203/185 mm	Avid Elixir X0 carbon, 185/185 mm	Avid Elixir CR Carbon, 185/185 mm
<b>Brake Levers</b>	Avid Elixir X0 carbon	Avid Elixir CR	Avid Elixir R	Avid Elixir X0 carbon	Avid Elixir CR Carbon
<b>Saddle</b>	Prologo X10 CrMo	Prologo Vertigo CrMo	Cannondale Stage CrMo	Fi'zi:k Tundra2 Crb	Fi'zi:k Gobi Mg
<b>Seatpost</b>	RockShox Reverb 31.6 x 385 mm height adjustable	Cannondale C2 31.6 x 350 mm	Cannondale C2 31.6 x 350 mm	RockShox Reverb 31.6 x 385 mm height adjustable	RockShox Reverb 31.6 x 385 mm height adjustable
<b>Sizes</b>	S, M, L, X	S, M, L, X	S, M, L, X	S, M, L, X	S, M, L, X
<b>Color 1 (code)</b>	Magnesium White (gloss) (WHT).	Jet Black (gloss) (BLK).	Jet Black (matte) (BBQ).	Exposed Carbon w/Magnesium White accents (matte) (BBQ).	Magnesium White w/Berserker Green accents (gloss) (WHT2).
<b>Extras</b>	Cannondale alloy locking grips w/closed end	Cannondale alloy locking grips w/closed end	Cannondale alloy locking grips w/closed end	Cannondale alloy locking grips w/closed end	Cannondale alloy locking grips w/closed end
	<b>JEKYLL CARBON 2</b>	<b>JEKYLL 3</b>	<b>JEKYLL 4</b>	<b>JEKYLL 5</b>	<b>RZ ONE TWENTY 1</b>
<b>Code</b>	1VN2	1VN3	1VN4	1VN5	1VL1
<b>Frame</b>	JeKyll, 150/90 mm, BallisTec Hi-MOD Carbon, BB30, ISCG03, 1.5 Si head tube	JeKyll, 150/90 mm, SmartFormed Alloy, BB30, ISCG03, 1.5 Si head tube	JeKyll, 150/90 mm, SmartFormed Alloy, BB30, ISCG03, 1.5 Si head tube	JeKyll, 150/90 mm, SmartFormed Alloy, BB30, ISCG03, 1.5 Si head tube	RZ One Twenty, 120 mm, SmartFormed Alloy, BB30, 1.5 Si head tube
<b>Fork</b>	Fox 32 Talas RL w/Custom Lockout Threshold, 150 mm, 15QR thru axle, 1.5"	Fox 32 Talas RL w/Custom Lockout Threshold, 150 mm, 15QR thru axle, 1.5"	Fox 32 Float RL w/Custom Lockout Threshold, 150 mm, 15QR thru axle, 1.5"	RockShox Revelation, 150 mm, Dual Air, All Travel, lockout, rebound, 15 mm thru axle, 1.5"	Lefty Ultra PBR, 120 mm, OPI, Solo Air
<b>Rear Shock</b>	Fox DYAD RT2 dual shock 150/90 mm	Fox DYAD RT2 dual shock 150/90 mm	Fox DYAD RT2 dual shock 150/90 mm	Fox DYAD RT2 dual shock 150/90 mm	RockShox Monarch RT3
<b>Rims</b>	SunRingle BlackFlag Expert +, tubeless ready	DT Swiss M480, 32 hole	Mavic XM317, 32 hole	Sun SR25, 32 hole	Mavic XM317, 32 hole
<b>Hubs</b>	SunRingle BlackFlag PrExpert +, 24 hole, 15 mm front, 142 x 12 mm rear	Formula, 15 mm front, 142 x 12 mm rear	Formula, 15 mm front, 142 x 12 mm rear	Formula, 15 mm front, 142 x 12 mm rear	Lefty SL front, Shimano M525 rear
<b>Spokes</b>	SunRingle BlackFlag Expert +	DT Swiss Champion	DT Swiss Champion	DT Swiss Champion	DT Swiss Competition
<b>Tires</b>	Schwalbe Nobby Nic PaceStar, 2.4" tubeless ready	Schwalbe Nobby Nic PaceStar, 2.4" tubeless ready	Kenda Nevegal folding, 2.35"	Kenda Nevegal folding, 2.35"	Schwalbe Rocket Ron Performance, 2.1" folding
<b>Pedals</b>	N/A	N/A	N/A	N/A	N/A
<b>Crank</b>	FSA Afterburner BB30, 44/32/24	FSA Afterburner BB30, 44/32/24	Fire-X 3.3, 44/32/22	Fire-X 3.1, 44/32/22	FSA Afterburner 386 BB30, 39-27
<b>Bottom Bracket</b>	FSA BB30	FSA BB30	Included	Included	FSA BB30
<b>Chain</b>	KMC X10SL, 10-speed	Shimano HG74, 10-speed	KMC X9, 9-speed	KMC X9, 9-speed	KMC X10SL, 10-speed
<b>Rear Cogs</b>	Shimano SLX, 11-36, 10-speed	Shimano SLX, 11-36, 10-speed	SRAM PG-950, 11-34, 9-speed	SRAM PG-950, 11-34, 9-speed	Shimano SLX, 11-36, 10-speed
<b>Front Derailleur</b>	SRAM X7	Shimano SLX	Shimano SLX	Shimano SLX	SRAM X9
<b>Rear Derailleur</b>	SRAM X9	Shimano XT	SRAM X9	SRAM X7	SRAM X9
<b>Shifters</b>	SRAM X9	Shimano XT	SRAM X7	SRAM X7	SRAM X9
<b>Handlebar</b>	Cannondale C2 riser, 680 x 20 mm, 2014 alloy	Cannondale C2 riser, 680 x 20 mm, 2014 alloy	Cannondale C3 riser, 680 x 20 mm, 6061 alloy	Cannondale C3 riser, 680 x 20 mm, 6061 alloy	Cannondale C2 riser, 680 x 20 mm, 2014 alloy
<b>Stem</b>	Cannondale C2, 1.5", 31.8	Cannondale C2, 1.5", 31.8	Cannondale C4, 1.5", 31.8	Cannondale C4, 1.5", 31.8	Cannondale OPI adjustable, 6 degree, 31.8
<b>Headset</b>	Tange Seiki 1.5", Integrated	Tange Seiki 1.5", Integrated	Tange Seiki 1.5", Integrated	Tange Seiki 1.5", Integrated	Cannondale HeadShok Si
<b>Brakes</b>	Avid Elixir CR, 185/185 mm	Avid Elixir CR, 185/185 mm	Avid Elixir R, 185/185 mm	Avid Elixir 3, 185/185 mm	Avid Elixir R Carbon, 185/160 mm
<b>Brake Levers</b>	Avid Elixir CR	Avid Elixir CR	Avid Elixir R	Avid Elixir 3	Avid Elixir R Carbon
<b>Saddle</b>	Cannondale Stage CrMo	Cannondale Stage CrMo	Cannondale Stage CrMo	Cannondale Stage 2	Prologo X10 CrMo
<b>Seatpost</b>	Cannondale C2, 31.6 x 350 mm	Cannondale C2, 31.6 x 350	Cannondale C2, 31.6 x 350	Cannondale C4, 31.6 x 400	Cannondale C2, 31.6 x 400
<b>Sizes</b>	S, M, L, X	S, M, L, X	S, M, L, X	S, M, L, X	S, M, L, X
<b>Color 1 (code)</b>	Charcoal Grey w/Jet Black accents (matte) (GRY).	Ultra Blue w/Single Malt Brown accents (gloss) (BLU).	Vintage Moss w/Magnesium White accents (gloss) (GRN).	Orange Spice, Magnesium White (gloss) (ORG).	Jet Black (matte) (BBQ).
<b>Color 2 (code)</b>		Magnesium White w/Red and Black accents (gloss) (WHT).	Magnesium White w/Red and Black accents (gloss) (WHT).	Magnesium White w/Red and Black accents (gloss) (WHT).	Magnesium White w/Red and Black accents (gloss) (WHT).
<b>Extras</b>	Cannondale alloy locking grips w/closed end	Cannondale alloy locking grips	Cannondale alloy locking grips w/closed end	Cannondale alloy locking grips w/closed end	Cannondale alloy locking grips w/closed end

	<b>RZ ONE TWENTY 2</b>	<b>RZ ONE TWENTY 3</b>	<b>RZ ONE TWENTY 4</b>	<b>SCALPEL ULTIMATE</b>	<b>SCALPEL 1</b>
<b>Code</b>	1VL2	1VL3	1VL4	1VP0	1VP1
<b>Frame</b>	RZ One Twenty, 120 mm, SmartFormed Alloy, BB30, 1.5 Si head tube	RZ One Twenty, 120 mm, SmartFormed Alloy, BB30, 1.5 Si head tube	RZ One Twenty, 120 mm, SmartFormed Alloy, BB30, 1.5 Si head tube	Scalpel, 80 mm, BallisTec Hi-MOD full carbon, Zero Pivot, BB30, 1.5 Si head tube	Scalpel, 80 mm, BallisTec Hi-MOD full carbon, Zero Pivot, BB30, 1.5 Si head tube
<b>Fork</b>	Lefty Ultra PBR, 120 mm, OPI, Solo Air	RockShox Recon Silver TK, 120 mm, Solo Air, lockout, rebound, 20 mm thru axle, 1.5"	RST Deuce Air, 120 mm, lockout, rebound, 15 mm thru axle, 1.5"	Lefty Speed Carbon XLR, 100 mm, OPI, Solo Air	Lefty Speed Carbon PBR, 100 mm, OPI, Solo Air
<b>Rear Shock</b>	Fox RP2	X Fusion 02 RL2	X Fusion 02 RL2	RockShox Monarch RT3	Fox RP23 w/Boost Valve
<b>Rims</b>	Mavic XM317, 32 hole	Mavic XM317, 32 hole	Maddux, 32 hole	DT Swiss XCR 1.2 Custom, 24 hole front, 28 hole rear	Mavic CrossMax SLR Lefty, tubeless
<b>Hubs</b>	Lefty SL front, Shimano M525 rear	Formula 20 mm front, Shimano M475 rear	Formula, DC51 front, DC22 rear	Cannondale Lefty SL front, DT Swiss 190 rear	Mavic CrossMax SLR Lefty
<b>Spokes</b>	DT Swiss Competition	DT Swiss Champion	DT Swiss Champion	DT Swiss Aerospeed	Mavic CrossMax SLR Lefty
<b>Tires</b>	Kenda Slant 6, 2.1", folding	Kenda Slant 6, 2.1", wire bead	Kenda Slant 6, 2.1", wire bead	Schwalbe Racing Ralph PaceStar, 2.1" tubeless ready front, Schwalbe Furious Fred PaceStar, 2.0" tubeless ready rear	Schwalbe Racing Ralph PaceStar, 2.1" tubeless ready
<b>Pedals</b>	N/A	Wellgo Platform	Wellgo Platform	N/A	N/A
<b>Crank</b>	Shimano M552, 42/32/24	Shimano M542, 44/32/22	Shimano M430-8, 44/32/22	Cannondale Hollowgram SL, 42-28 w/XX chainrings	FSA SL-K 386 BB30, 42-27
<b>Bottom Bracket</b>	Included	Included	Shimano BB-ES25, Octalink	Cannondale BB30	FSA BB30
<b>Chain</b>	Shimano HG74, 10-speed	KMC X9, 9-speed	KMC X9, 9-speed	KMC X10SL, 10-speed	Shimano M980, 10-speed
<b>Rear Cogs</b>	Shimano SLX, 11-36, 10-speed	SRAM PG-950, 11-34, 9-speed	SRAM PG-950, 11-34, 9-speed	SRAM XX, 11-36, 10-speed	Shimano XTR, 11-36, 10-speed
<b>Front Derailleur</b>	Shimano SLX	Shimano Deore	Shimano Alivio	SRAM XX	Shimano XTR
<b>Rear Derailleur</b>	Shimano XT	SRAM X9	Shimano Deore	SRAM XX	Shimano XTR
<b>Shifters</b>	Shimano XT	SRAM X7	Shimano Deore	SRAM XX	Shimano XTR
<b>Handlebar</b>	Cannondale C2 riser, 680 x 20 mm, 2014 alloy	Cannondale C3 riser, 680 x 20 mm, 6061 alloy	Cannondale C3 riser, 680 x 20 mm, 6061 alloy	FSA K-Force flat 600 mm	FSA SL-K flat 620 mm
<b>Stem</b>	Cannondale C1 HeadShok, 31.8	Cannondale C2, 1.5", 31.8	Cannondale C2, 1.5", 31.8	Cannondale OPI adjustable, -5 degree, 31.8	Cannondale OPI adjustable, -5 degree, 31.8
<b>Headset</b>	HeadShok	Tange Seiki, 1.5", Integrated	Tange Seiki, 1.5", Integrated	Cannondale HeadShok Si	Cannondale HeadShok Si
<b>Brakes</b>	Hayes Stroker Trail Carbon, 180/160 mm	Avid Elixir 3, 180/160 mm	Shimano M445, 180/160 mm	SRAM XX, 160/140 mm	Magura Marta SL Carbon, 160/140 mm
<b>Brake Levers</b>	Hayes Stroker Trail Carbon	Avid Elixir 3	Shimano M445	SRAM XX	Magura Marta SL Carbon
<b>Saddle</b>	Prologo X10 STN	Cannondale Stage 2	Cannondale Stage 2	Fi'zi:k Antares Tundra2 Crb	Fi'zi:k Tundra2 Km
<b>Seatpost</b>	Cannondale C2, 31.6 x 400	Cannondale C4, 31.6 x 400	Cannondale C4, 31.6 x 400	FSA K-Force 25 mm offset, 31.6 x 400	Fi'zi:k Cyrano, 31.6 x 400
<b>Sizes</b>	S, M, L, X	S, M, L, X	S, M, L, X	S, M, L, X	S, M, L, X
<b>Color 1 (code)</b>	Berserker Green (gloss) (GRN).	Jet Black (gloss) (BLK).	Race Red (gloss) (RED).	Team Replica (gloss) (REP).	Magnesium White w/Jet Black accents (gloss) (WHT).
<b>Color 2 (code)</b>	Fine Silver (gloss) (SLV).	Nu Team Blue (gloss) (BLU).	Magnesium White w/Red and Black accents (gloss) (WHT).		
<b>Extras</b>	Cannondale alloy locking grips w/closed end	Cannondale alloy locking grips w/closed end	Cannondale alloy locking grips w/closed end	Cannondale foam locking grips	Cannondale foam locking grips
	<b>SCALPEL 2</b>	<b>SCALPEL 3</b>	<b>FLASH ULTIMATE</b>	<b>FLASH HI-MOD 1</b>	<b>FLASH CARBON 4</b>
<b>Code</b>	1VP2	1VP3	1FS0S	1FS1S	1FS4S
<b>Frame</b>	Scalpel, 80 mm, BallisTec Hi-MOD full carbon, Zero Pivot, BB30, 1.5 Si head tube	Scalpel, 80 mm, BallisTec Hi-MOD full carbon, Zero Pivot, BB30, 1.5 Si head tube	Flash, BallisTec Hi-MOD Carbon, SAVE, BB30, 1.5 Si head tube	Flash, BallisTec Hi-MOD Carbon, SAVE, BB30, 1.5 Si head tube	Flash, BallisTec Carbon, SAVE, BB30, 1.5 Si head tube
<b>Fork</b>	Lefty Speed XLR, 100 mm, OPI, Solo Air	Lefty Speed PBR, 100 mm, OPI, Solo Air	Lefty Speed Carbon XLR, 100 mm, OPI, Solo Air	Lefty Speed Carbon PBR, 100 mm, OPI, Solo Air	Lefty Speed PBR, 100 mm, OPI, Solo Air
<b>Rear Shock</b>	RockShox Monarch RT3	Fox RP2	N/A	N/A	N/A
<b>Rims</b>	SunRingle BlackFlag Pro, 24 hole, tubeless ready	DT Swiss XCR 1.7 Custom, 24 hole	DT Swiss XCR 1.2 Custom, 24 hole front, 28 hole rear	Mavic CrossMax SLR Lefty, tubeless	Mavic XM317, 32 hole
<b>Hubs</b>	SunRingle BlackFlag Pro Lefty	Lefty SL front, DT Swiss 340 rear	Cannondale Lefty SL front, DT Swiss 190 rear	Mavic CrossMax SLR Lefty	Lefty SL front, SRAM X9 rear
<b>Spokes</b>	SunRingle BlackFlag Pro	DT Swiss Competition	DT Swiss Aerospeed	Mavic CrossMax SLR Lefty	DT Swiss Competition
<b>Tires</b>	Schwalbe Racing Ralph PaceStar, 2.1" tubeless ready	Schwalbe Racing Ralph PaceStar, 2.1" tubeless ready	Schwalbe Racing Ralph PaceStar, 2.1" tubeless ready front, Schwalbe Furious Fred PaceStar, 2.0" tubeless ready rear	Schwalbe Racing Ralph PaceStar, 2.1" tubeless ready	Schwalbe Rocket Ron Performance, 2.1" folding
<b>Pedals</b>	N/A	N/A	N/A	N/A	N/A
<b>Crank</b>	FSA Afterburner 386 BB30, 42-27	FSA Afterburner 386 BB30, 42-27	Cannondale Hollowgram SL, 42-28 w/XX chainrings	FSA K-Force 386 BB30, 42-27	SRAM S1400 BB30 2.2, 42/27
<b>Bottom Bracket</b>	FSA BB30	FSA BB30	Cannondale BB30	FSA BB30	FSA BB30
<b>Chain</b>	KMC X10SL, 10-speed	Shimano HG74, 10-speed	KMC X10SL, 10-speed	Shimano M980, 10-speed	KMC X10SL, 10-speed
<b>Rear Cogs</b>	Shimano XT, 11-36, 10-speed	Shimano SLX, 11-36, 10-speed	SRAM XX, 11-36, 10-speed	Shimano XTR, 11-36, 10-speed	Shimano, 11-36, 10-speed
<b>Front Derailleur</b>	SRAM X9	Shimano SLX	SRAM XX	Shimano XTR	SRAM X7
<b>Rear Derailleur</b>	SRAM X0	Shimano XT	SRAM XX	Shimano XTR	SRAM X9
<b>Shifters</b>	SRAM X0	Shimano SLX	SRAM XX	Shimano XTR	SRAM X7
<b>Handlebar</b>	Cannondale C2 riser, 620 x 3 mm, 2014 alloy	Cannondale C2 riser, 620 x 3 mm, 2014 alloy	FSA K-Force flat 600 mm	FSA SL-K flat 620 mm	Cannondale C2 riser, 620 x 3 mm, 2014 alloy
<b>Stem</b>	Cannondale OPI adjustable, -5 degree, 31.8	Cannondale OPI adjustable, -5 degree, 31.8	Cannondale OPI adjustable, -5 degree, 31.8	Cannondale OPI adjustable, -5 degree, 31.8	Cannondale C2, 31.8
<b>Headset</b>	Cannondale HeadShok Si	HeadShok	Cannondale HeadShok Si	Cannondale HeadShok Si	Cannondale HeadShok Si
<b>Brakes</b>	Avid Elixir CR carbon, 160/140 mm	Avid Elixir R, 160/140 mm	SRAM XX, 160/140 mm	Magura Marta SL Carbon, 160/140 mm	Avid Elixir R, 160/160 mm
<b>Brake Levers</b>	Avid Elixir CR carbon	Avid Elixir R	SRAM XX		
<b>Saddle</b>	Fi'zi:k Tundra2 Mg	Cannondale Stage CrMo	Fi'zi:k Antares Crb	Fi'zi:k Tundra2 Km	Prologo X10 STN
<b>Seatpost</b>	Cannondale C2, 31.6 x 400	Cannondale C2, 31.6 x 400	Flash Carbon, 27.2 x 420 mm w/SAVE	Flash Carbon 27.2 x 420 mm w/SAVE	Cannondale C2, 27.2 x 400 mm
<b>Sizes</b>	S, M, L, X	S, M, L, X	S, M, L, X	S, M, L, X	S, M, L, X
<b>Color 1 (code)</b>	Charcoal Grey w/Jet Black accents (gloss) (GRY).	Jet Black w/Magnesium White accents (gloss) (BLK).	Team Replica (gloss) (REP).	Magnesium White w/Jet Black accents (gloss) (WHT).	Race Red w/Magnesium White accents (gloss) (RED).
<b>Extras</b>	Cannondale alloy locking grips w/closed end	Cannondale alloy locking grips w/closed end	Cannondale foam locking grips	Cannondale foam locking grips	Cannondale foam locking grips

	<b>FLASH F1</b>	<b>FLASH F2</b>	<b>FLASH F3</b>	<b>TRAIL SL 2</b>	<b>TRAIL SL 3</b>
<b>Code</b>	1FA1	1FA2	1FA3	1FS2	1FS3
<b>Frame</b>	Flash, SmartFormed alloy, SAVE, BB30, 1.5 Si head tube	Flash, SmartFormed alloy, SAVE, BB30, 1.5 Si head tube	Flash, SmartFormed alloy, SAVE, BB30, 1.5 Si head tube	Trail SL, Optimized 6061 alloy, SAVE, 1.5" head tube	Trail SL, Optimized 6061 alloy, SAVE, 1.5" head tube
<b>Fork</b>	Lefty Speed PBR, 100 mm, OPI, Solo Air	Lefty Speed PBR, 100 mm, OPI, Solo Air	Fatty DLR80, 80 mm, OPI	RockShox Recon Silver TK, 100 mm, Solo Air, lockout, rebound, 1.5"	RST Deuce Coil, 100 mm, coil/elastomer, lockout, rebound, 1.5"
<b>Rims</b>	Mavic XM317, 32 hole	Mavic XM317, 32 hole	Maddux DC3.0, double wall w/eyelet, 32 hole	Maddux DC3.0, double wall w/eyelet, 28 hole front, 32 hole rear	Maddux DC3.0, double wall w/eyelet, 28 hole front, 32 hole rear
<b>Hubs</b>	Lefty SL front, SRAM X9 rear	Lefty SL front, Shimano M525 rear	Shimano, M475 front, M475 rear	Formula, DC20 front, DC22 rear	Formula, DC20 front, DC22 rear
<b>Spokes</b>	DT Swiss Competition	DT Swiss Champion	DT Swiss Champion	Stainless Steel Black Spokes 15g	Stainless Steel Black Spokes 15g
<b>Tires</b>	Kenda Small Block 8, 2.1", folding	Kenda Small Block 8, 2.1", folding	Kenda Slant 6, 2.1", wire bead	Kenda Small Block 8, 2.1", wire bead	Kenda Small Block 8, 2.1", wire bead
<b>Pedals</b>	N/A	Wellgo Platform	Wellgo Platform	VP Platform w/steel cage	VP Platform w/steel cage
<b>Crank</b>	FSA Afterburner 386 BB30, 39/27	Shimano M542, 44/32/22	Shimano FC-M430-8, 44/32/22	Shimano FC-M430-8, 44/32/22	Shimano FC-M430-8, 44/32/22
<b>Bottom Bracket</b>	FSA BB30	Included	Shimano ES-25 Octalink	Shimano ES-25 Octalink	Shimano ES-25 Octalink
<b>Chain</b>	KMC X10SL, 10-speed	KMC X9, 9-speed	KMC X9, 9-speed	Shimano HG53, 9-speed	Shimano HG53, 9-speed
<b>Rear Cogs</b>	Shimano SLX, 11-36, 10-speed	SRAM PG-950, 11-34, 9-speed	SRAM PG-950, 11-34, 9-speed	SRAM PG-950, 11-32, 9-speed	SRAM PG-950, 11-34, 9-speed
<b>Front Derailleur</b>	SRAM X7	Shimano Deore	Shimano Deore	Shimano Alivio	SRAM X5
<b>Rear Derailleur</b>	SRAM X9	Shimano XT	SRAM X7	Shimano Deore	SRAM X5
<b>Shifters</b>	SRAM X7	Shimano SLX	SRAM X7	Shimano Deore	SRAM X5
<b>Handlebar</b>	Cannondale C2 riser, 620 x 3 mm, 2014 alloy	Cannondale C2 riser, 620 x 3 mm, 2014 alloy	Cannondale C3 riser, 680 x 20 mm, 6061 alloy	Cannondale C3 riser, 680 x 20 mm, 6061 alloy	Cannondale C3 riser, 680 x 20 mm, 6061 alloy
<b>Stem</b>	Cannondale OPI adjustable, -5 degree, 31.8	Cannondale C1 HeadShok, 31.8	Cannondale C1 HeadShok, 31.8	Cannondale C4 1.5", 31.8	Cannondale C4 1.5", 31.8
<b>Headset</b>	Cannondale HeadShok Si	Cannondale HeadShok Si	Cannondale HeadShok Si	Tange Custom 1.5"	Tange Custom 1.5"
<b>Brakes</b>	Avid Elixir R, 160/160 mm	Shimano BR-M505, 160/160 mm	Hayes Ryde Comp, 160/160 mm	Shimano BR-M445 Hydraulic Disc, 160/160 mm	Tektro Draco SL Custom Hydraulic Disc, 160/160 mm
<b>Brake Levers</b>	Avid Elixir R	Shimano BR-M505	Hayes Ryde Comp	Shimano BR-M445	Tektro Draco SL
<b>Saddle</b>	Prologo X10 STN	Cannondale Stage 2	Cannondale Stage 2	Cannondale Stage 2	Cannondale Stage 2
<b>Seatpost</b>	Cannondale C2, 31.6 x 400 mm	Cannondale C2, 31.6 x 400 mm	Cannondale C4, 31.6 x 400 mm	Cannondale C3, 31.6 x 350 mm, 400 (L, X, J)	Cannondale C3, 31.6 x 350 mm, 400 (L, X, J)
<b>Sizes</b>	S, M, L, X	S, M, L, X	S, M, L, X	S, M, L, X, J	S, M, L, X, J
<b>Color 1 (code)</b>	Magnesium White (gloss) (WHT).	Race Red (gloss) (RED).	Jet Black (matte) (BBQ).	Jet Black (gloss) (BLK).	Jet Black (matte) (BBQ).
<b>Color 2 (code)</b>			Magnesium White (gloss) (WHT).	Nu Team Blue (gloss) (BLU).	Magnesium White (gloss) (WHT).
<b>Extras</b>	Cannondale alloy locking grips w/closed end	Cannondale alloy locking grips w/closed end	Cannondale alloy locking grips w/closed end	Cannondale alloy locking grips w/closed end	Cannondale alloy locking grips w/closed end

	<b>TRAIL SL 4</b>	<b>TRAIL 5</b>	<b>TRAIL 6</b>	<b>FLASH HI-MOD 29'ER 1</b>	<b>FLASH CARBON 29'ER 2</b>
<b>Code</b>	1FS4	1FS5	1FS6	1FS291S	1FS292S
<b>Frame</b>	Trail SL, Optimized 6061 alloy, SAVE, 1.5" head tube	Trail, double butted 6061 alloy, SAVE, 1-1/8" head tube	Trail, double butted 6061 alloy, SAVE, 1-1/8" head tube	Flash 29'er, BallisTec Hi-MOD Carbon, SAVE, BB30 1.5 Si head tube	Flash 29'er, BallisTec Carbon, SAVE, BB30 1.5 Si head tube
<b>Fork</b>	RST Deuce TNL, 100 mm, coil/elastomer, lockout, 1.5"	RST Gila Pro TNL, 100 mm, coil/elastomer, lockout, 1-1/8"	RST Gila T, 100 mm, coil w/ elastomer, 1-1/8"	Lefty 29'er Carbon XLR, 90 mm, OPI, Solo Air	Lefty 29'er Carbon PBR, 90 mm, OPI, Solo Air
<b>Rims</b>	Alex DC4.5, double wall, 28 hole front, 32 hole rear	Alex DC4.5, double wall, 32 hole	Alex DC4.5, double wall, 32 hole	DT Swiss XCR 1.2 Custom, 24 hole front, 28 hole rear	DT Swiss XCR 1.2 Custom, 24 hole front, 28 hole rear
<b>Hubs</b>	Formula, DC20 front, DC22 rear	Formula, DC20 front, DC22 rear	Formula, DC20 front, DC22 rear	Cannondale Lefty SL front, DT Swiss 240S rear	Cannondale Lefty SL front, Sun Dirty Flea rear
<b>Spokes</b>	Stainless Steel Black Spokes 15g	Stainless Steel Black Spokes 15g	Stainless Steel Black Spokes 15g	DT Aerospeed	DT Swiss Competition BLK 2 mm
<b>Tires</b>	Kenda Small Block 8, 2.1", wire bead	Kenda Small Block 8, 2.1", wire bead	Kenda Small Block 8, 2.1", wire bead	Schwalbe Racing Ralph PaceStar, 2.25" tubeless ready	Schwalbe Racing Ralph PaceStar, 2.25" tubeless ready
<b>Pedals</b>	VP Platform w/steel cage	FPD Platform w/steel cage	FPD Platform w/steel cage	N/A	N/A
<b>Crank</b>	Shimano FC-M361, 42/32/22	Shimano, FC-M311, 42/32/22	Shimano, FC-M191, 42/34/24	Cannondale Hollowgram SL, 39-26 w/XX chainrings	FSA SL-K 386 BB30, 39-27
<b>Bottom Bracket</b>	Tange Seiki LN-3912	Tange Seiki LN-3912	Tange Seiki LN-3912	Cannondale BB30	FSA BB30
<b>Chain</b>	KMC Z-72, 8-speed	KMC Z-72, 8-speed	KMC Z-72, 8-speed	KMC X10SL 111 links	KMC X10SL
<b>Rear Cogs</b>	Sun Race M66, 12-32, 8-speed	Sun Race M66 12-32, 8-speed	Sun Race M56 12-32, 8-speed	Shimano XT M771-10, 11-36	Shimano XT, 11-36, 10-speed
<b>Front Derailleur</b>	Shimano FD-M311	Shimano FD-M311	Shimano FD-M190	SRAM X9	KMC X10SL
<b>Rear Derailleur</b>	Shimano Alivio	Shimano Alivio	Shimano Acera	SRAM X0	KMC X10SL
<b>Shifters</b>	Shimano Alivio	Shimano Alivio	Shimano Acera	SRAM X0	KMC X10SL
<b>Handlebar</b>	Cannondale C3 riser, 680 x 20 mm, 6061 alloy	Cannondale C4 riser, 660 x 30 mm, 6061 alloy	Cannondale C4 riser, 660 x 30 mm, 6061 alloy	TruVativ Stylo World Cup Flat, 680 mm	TruVativ Stylo World Cup Flat, 680 mm
<b>Stem</b>	Cannondale C4 1.5", 31.8	Cannondale C4 by UNO, 31.8	Cannondale C4 by UNO, 31.8	Cannondale OPI adjustable, -5 degree, 31.8	Cannondale OPI adjustable, -5 degree, 31.8
<b>Headset</b>	Tange Custom 1.5"	Tange ER2 Slim Stack	Tange ER2 Slim Stack	HeadShok	HeadShok
<b>Brakes</b>	Promax Orange Mechanical Disc, 160/160 mm	Promax Orange Mechanical Disc, 160/160 mm	Tektro Novela Mechanical Disc, 160/160 mm	Avid Elixir X0 carbon, 185/160 mm	Avid Elixir CR carbon, 185/160 mm
<b>Brake Levers</b>	Cannondale	Cannondale	Cannondale	Avid Elixir X0 carbon	Avid Elixir CR carbon
<b>Saddle</b>	Cannondale Stage 2	Cannondale Stage 2	Cannondale Stage 2	Fi'zi:k Tundra2 Mg	Prologo X10 Cro-Mo
<b>Seatpost</b>	Cannondale C3, 31.6 x 350 mm, 400 (L, X, J)	Cannondale C4, 31.6 mm	Cannondale C4, 31.6 mm	Flash Carbon, 27.2 x 420 w/SAVE	Flash Carbon, 27.2 x 420 w/SAVE
<b>Sizes</b>	S, M, L, X, J	S, M, L, X, J	S, M, L, X, J	M, L, X	M, L, X
<b>Color 1 (code)</b>	Race Red (gloss) (RED).	Jet Black (gloss) (BLK2).	Soldier of Fortune (matte) (GRN).	Exposed Carbon w/Magnesium White accents (matte) (BBQ).	Magnesium White w/Jet Black accents (gloss) (WHT).
<b>Color 2 (code)</b>	Fine Silver (matte) (SLV).	Nu Team Blue (gloss) (BLU).	Magnesium White (gloss) (WHT).		
<b>Extras</b>	Cannondale Dual Density grips	Cannondale Dual Density grips	Cannondale Dual Density grips	Cannondale foam locking grips	Cannondale foam locking grips



	<b>FLASH CARBON 29'ER 3</b>	<b>FLASH 29'ER 1</b>	<b>FLASH 29'ER 2</b>	<b>TRAIL SL 29'ER 2</b>	<b>TRAIL SL 29'ER 3</b>
<b>Code</b>	1FS293S	1FA291	1FA292	1FS292	1FS293
<b>Frame</b>	Flash 29'er, BallisTec Carbon, SAVE, BB30, 1.5 Si head tube	Flash 29'er, SmartFormed alloy, SAVE, BB30, 1.5 Si head tube	Flash 29'er, SmartFormed alloy, SAVE, BB30, 1.5 Si head tube	Trail SL 29'er, Optimized 6061 alloy, SAVE, 1.5" head tube	Trail SL 29'er SS, Optimized 6061 alloy, SAVE, 1.5" head tube
<b>Fork</b>	Lefty 29'er PBR, 90 mm, OPI, Solo Air	Lefty 29'er PBR, 90 mm, OPI, Solo Air	Lefty 29'er PBR, 90 mm, OPI, Solo Air	RST Deuce 29 Air, 80 mm, lockout, rebound, 1.5"	RST Deuce 29 Air, 80 mm, lockout, rebound, 1.5"
<b>Rims</b>	Sun EQ25, welded, w/eyelet, 29'er, 32 hole	Sun EQ25, welded, w/eyelet, 29'er, 32 hole	Sun SR25, w/eyelet, 29'er, 32 hole	Maddux DC3.0 29'er, double wall w/eyelet, 32 hole	Maddux DC3.0 29'er, double wall w/eyelet, 32 hole
<b>Hubs</b>	Cannondale Lefty SL front, SRAM X9 rear	Cannondale Lefty SL front, SRAM X9 rear	Cannondale Lefty SL front, Shimano M529 rear	Formula DC20 front, Shimano M529 rear	Formula DC20 front, DCS2 rear
<b>Spokes</b>	DT Swiss Competition BLK 2 mm	DT Swiss Competition	DT Swiss Champion	Stainless Steel, black, 15g	Stainless Steel, black, 15g
<b>Tires</b>	Schwalbe Racing Ralph PaceStar, 2.25" tubeless ready	Kenda Small Block 8, 29 x 2.1"	Kenda Small Block 8, 29 x 2.1"	Kenda Small Block 8, 29 x 2.1", wire bead	Kenda Small Block 8, 29x2.1", wire bead
<b>Pedals</b>	N/A	N/A	Wellgo Platform	VP Platform with steel cage	VP Platform with steel cage
<b>Crank</b>	FSA Afterburner 386 BB30, 39-27	FSA Afterburner 386 BB30, 39-27	Shimano M542, 44/32/22	Shimano FC-M430-8 Octalink, 44/32/22	TruVatiV Isoflow 1.0g SS, 33T
<b>Bottom Bracket</b>	FSA BB30	FSA BB30	Included	Shimano ES-25 Octalink	Tange Seiki LN-3912
<b>Chain</b>	KMC X10SL, 10-speed	KMC X10SL, 10-speed	KMC X10SL	Shimano HG53, 9-speed	KMC Z-99 SS
<b>Rear Cogs</b>	Shimano SLX, 11-36, 10-speed	Shimano SLX HG81-10, 11-36, 10-speed	SRAM PG-950 11-34, 9-speed	Shimano HG-61, 12-36, 9-speed	Formula 20
<b>Front Derailleur</b>	SRAM X7	SRAM X7	Shimano Deore	Shimano Alivio	N/A
<b>Rear Derailleur</b>	SRAM X9	SRAM X9	Shimano XT	Shimano Deore	N/A
<b>Shifters</b>	SRAM X7	SRAM X7	Shimano SLX	Shimano Deore Trigger	N/A
<b>Handlebar</b>	Cannondale C2 flat, 680 mm, 2014 alloy	Cannondale C2 flat, 680 mm, 2014 alloy	Cannondale C3 riser, 31.8 x 20 mm, 6061	Cannondale C3 riser, 680 x 20 mm, 6061 alloy	Cannondale C3 riser, 680 x 20 mm, 6061 alloy
<b>Stem</b>	Cannondale OPI adjustable, -5 degree, 31.8	Cannondale OPI adjustable, -5 degree, 31.8	Cannondale C1 HeadShok, 31.8	Cannondale C4 1.5", 31.8	Cannondale C4 1.5", 31.8
<b>Headset</b>	HeadShok	HeadShok	HeadShok	Tange Custom 1.5"	Tange Custom 1.5"
<b>Brakes</b>	Avid Elixir CR, 185/160 mm	Avid Elixir R, 185/160 mm	Shimano BR-M505, 160/160 mm	Shimano BR-M445 Hydraulic Disc, 160/160 mm	Promax Orange Mechanical Disc, 160/160 mm
<b>Brake Levers</b>	Avid Elixir CR	Avid Elixir R	Shimano BR-M505	Shimano BR-M445	Cannondale
<b>Saddle</b>	Prologo X10 Cro-Mo	Prologo X10 STN	Cannondale Stage 2	Cannondale Stage 2	Cannondale Stage 2
<b>Seatpost</b>	Cannondale C2, 27.2 x 400	Cannondale C2, 27.2 x 400	Cannondale C2, 27.2 x 400	Cannondale C3, 31.6 x 400	Cannondale C3, 31.6 x 400
<b>Sizes</b>	M, L, X	M, L, X	M, L, X	M, L, X	M, L, X
<b>Color 1 (code)</b>	Magnesium White w/Race Red accents (gloss) (RED).	Jet Black (gloss) (BLK).	Magnesium White (gloss) (WHT).	Jet Black (matte) (BBQ).	Lightning White (gloss) (WHT).
<b>Color 2 (code)</b>				Race Red (gloss) (RED).	
<b>Extras</b>	Cannondale foam locking grips	Cannondale alloy locking grips w/closed end	Cannondale alloy locking grips w/closed end	Cannondale alloy locking grips w/closed end	Cannondale alloy locking grips w/closed end

	<b>TRAIL SL 29'ER 4</b>	<b>SUPERSIX HI-MOD TEAM</b>	<b>SUPERSIX HI-MOD DI2</b>	<b>SUPERSIX HI-MOD 1 DURA-ACE</b>	<b>SUPERSIX HI-MOD 2 RED</b>
<b>Code</b>	1FS294	1RSH0D	1RSHID	1RSH1D	1RSH2D, 1RSH2C
<b>Frame</b>	Trail SL 29'er, Optimized 6061 alloy, SAVE, 1.5" head tube	SuperSix, Hi-Mod full carbon, BB30, SAVE, D12 specific	SuperSix, Hi-Mod full carbon, BB30, SAVE, D12 specific	SuperSix, Hi-Mod full carbon, BB30, SAVE	SuperSix, Hi-Mod full carbon, BB30, SAVE
<b>Fork</b>	RST Deuce 29 TNL, 80 mm, coil/elastomer, hydraulic lockout, 1.5"	SuperSix, Hi-MOD full carbon, 1-1/8"-1.5" tapered steerer	SuperSix, Hi-MOD full carbon, 1-1/8"-1.5" tapered steerer	SuperSix, Hi-Mod full carbon, 1-1/8"-1.5" tapered steerer	SuperSix, Hi-MOD full carbon, 1-1/8"-1.5" tapered steerer
<b>Rims</b>	Alex DC4.5 29'er, double wall, 32 hole	Mavic Cosmic Carbon SR, clincher	Mavic Kyrium SL, black	Mavic Kyrium SL, black	Mavic Ksyrium Elite
<b>Hubs</b>	Formula DC20 front, DC22 rear	Mavic Cosmic Carbon SR	Mavic Kyrium SL, black	Mavic Kyrium SL, black	Mavic Ksyrium Elite
<b>Spokes</b>	Stainless Steel, black, 15g	Mavic Cosmic Carbon SR	Mavic Kyrium SL, black	Mavic Kyrium SL, black	Mavic Ksyrium Elite
<b>Tires</b>	Kenda Small Block 8, 29 x 2.1", wire bead	Schwalbe Ultremo ZX, 700 x 23c	Schwalbe Ultremo ZX, 700 x 23c	Schwalbe Ultremo ZX, 700 x 23c	Schwalbe Ultremo ZX, 700 x 23c
<b>Pedals</b>	VP Platform with steel cage	N/A	N/A	N/A	N/A
<b>Crank</b>	FSA Alpha Drive, 42/32/22	Cannondale Hollowgram SL BB30, FSA CA-11 rings, 53/39 (50/34 rings and spider included)	Cannondale Hollowgram SL BB30, FSA DA-79 rings, 53/39 (50/34 rings and spider included)	Cannondale Hollowgram SL BB30, FSA DA-79 rings, 53/39 (50/34 rings and spider included)	SRAM RED w/Cannondale graphics, BB30, 53/39 (Option: compact 50/34)
<b>Bottom Bracket</b>	Tange Seiki LN-3912	Cannondale Hollowgram SL, ceramic bearings	Cannondale Hollowgram SL, ceramic bearings	Cannondale Hollowgram SL, ceramic bearings	SRAM BB30
<b>Chain</b>	KMC Z-72, 8-speed	Campagnolo Record, 11-speed	Shimano Dura-Ace 7900	Shimano Dura-Ace 7900	SRAM PC-1070
<b>Rear Cogs</b>	Sun Race M66, 12-34, 8-speed	Campagnolo Super Record, 12-25, 11-speed	Shimano Dura-Ace 7900, 11-25	Shimano Dura-Ace 7900, 11-25	SRAM PG-1070, 11-26
<b>Front Derailleur</b>	Shimano FD-M311	Campagnolo Super Record, 34.9 mm clamp, 11-speed	Shimano Di2, 34.9 mm clamp	Shimano Dura-Ace 7900, 34.9 mm clamp	SRAM RED, 34.9 mm clamp
<b>Rear Derailleur</b>	Shimano Alivio	Campagnolo Super Record, 11-speed	Shimano Di2	Shimano Dura-Ace 7900	SRAM RED
<b>Shifters</b>	Shimano Alivio	Campagnolo Super Record QS Carbon ErgoShifters, 11-speed	Shimano Di2	Shimano Dura-Ace 7900	SRAM RED
<b>Handlebar</b>	Cannondale C3 riser, 680 x 20 mm, 6061 alloy	FSA K-Force Light Nano K Carbon Compact	FSA K-Force Carbon Compact	FSA K-Force Carbon Compact	FSA Wing Pro Compact
<b>Stem</b>	Cannondale C4 1.5", 31.8	FSA OS-99 CSI, 31.8	FSA OS-99 CSI, 31.8	FSA OS-99 CSI, 31.8	FSA SL-K, 31.8
<b>Headset</b>	Tange Custom 1.5"	SuperSix, 1.5 lower bearing, 30 mm carbon, w/5 mm hidden alloy top cover	SuperSix, 1.5 lower bearing, 30 mm carbon, w/5 mm hidden alloy top cover	SuperSix, 1.5 lower bearing, 30 mm carbon, w/5 mm hidden alloy top cover	SuperSix, 1.5 lower bearing, 30 mm carbon, w/5 mm hidden alloy top cover
<b>Brakes</b>	Promax Orange Mechanical Disc, 160/160 mm	Campagnolo Super Record D-Skeleton	Shimano Dura-Ace 7900	Shimano Dura-Ace 7900	SRAM RED
<b>Brake Levers</b>	Cannondale	Campagnolo Super Record	Shimano Dura-Ace 7900	Shimano Dura-Ace 7900	SRAM RED
<b>Saddle</b>	Cannondale Stage 2	Fi'zi:k Antares, Team Rep, carbon rails	Fi'zi:k Antares, Kium rails	Fi'zi:k Antares, Kium rails	Fi'zi:k Antares, Mg rails
<b>Seatpost</b>	Cannondale C3, 31.6 x 400	FSA K-Force Carbon SP-RK-160, 31.6 mm, 350 mm	FSA K-Force Carbon SP-RK-160, 31.6 mm, 350 mm	FSA K-Force Carbon SP-RK-160, 31.6 mm, 350 mm	FSA SLK Carbon SP-RK-260, 31.6 mm, 350 mm
<b>Sizes</b>	M, L, X	48, 50, 52, 54, 56, 58, 60, 63cm	48, 50, 52, 54, 56, 58, 60, 63cm	48, 50, 52, 54, 56, 58, 60, 63cm	48, 50, 52, 54, 56, 58, 60, 63cm
<b>Color 1 (code)</b>	Berserker Green (gloss) (GRN).	Liquigas Team Replica (gloss) (LIQ).	Matte Carbon, White accents (CRB).	Magnesium White, Jet Black (gloss) (WHT).	Matte Carbon, White accents (CRB).
<b>Color 2 (code)</b>	Fine Silver (matte) (SLV).				Magnesium White, Jet Black (gloss) (WHT).
<b>Extras</b>	Cannondale Dual Density Grips	Compact Kit	Di2 Charger, power cable and Battery, Compact Kit, Di2 Satellite shift for top of the bar	Compact Kit	

	<b>SUPERSIX 1 DURA-ACE</b>	<b>SUPERSIX 3 ULTEGRA</b>	<b>SUPERSIX 4 RIVAL</b>	<b>SUPERSIX 5 105</b>	<b>CAAD10 1 DURA-ACE</b>
<b>Code</b>	1RSS1D, 1RSS1C	1RSS3D, 1RSS3C	1RSS4D, 1RSS4C	1RSS5D, 1RSS5C	1RAX1D, 1RAX3C
<b>Frame</b>	SuperSix, full carbon, BB30, SAVE	SuperSix, full carbon, BB30, SAVE	SuperSix, full carbon, BB30, SAVE	SuperSix, full carbon, BB30, SAVE	CAAD10, Smartformed 6069 Alloy, SAVE, BB30
<b>Fork</b>	SuperSix, full carbon, 1-1/8"-1.5" tapered steerer, alloy dropouts	SuperSix, full carbon, 1-1/8"-1.5" tapered steerer, alloy dropouts	SuperSix, full carbon, 1-1/8"-1.5" tapered steerer, alloy dropouts	SuperSix, full carbon, 1-1/8"-1.5" tapered steerer, alloy dropouts	CAAD10, full carbon, 1-1/8" to 1-1/4" tapered steerer
<b>Rims</b>	Mavic Equipe	Mavic Aksium	Mavic Aksium	Shimano RS10	Shimano RS80
<b>Hubs</b>	Mavic Equipe	Mavic Aksium	Mavic Aksium	Shimano RS10	Shimano RS80
<b>Spokes</b>	Mavic Equipe	Mavic Aksium	Mavic Aksium	Shimano RS10	Shimano RS80
<b>Tires</b>	Schwalbe Durano S, 700 x 23c, folding	Schwalbe Durano, 700 x 23c, folding	Schwalbe Durano, 700 x 23c, folding	Schwalbe Lugano, 700 x 23c, folding	Schwalbe Durano S, 700 x 23c, folding
<b>Pedals</b>	N/A	N/A	N/A	N/A	N/A
<b>Crank</b>	FSA SL-K Light Carbon, BB30, 53/39 (Option: compact 50/34)	FSA SL-K Light Carbon, BB30, 53/39 (Option: compact 50/34)	SRAM Force Carbon, BB30, 53/39 (Option: compact 50/34)	FSA Gossamer Pro, BB30, 53/39 (Option: compact 50/34)	FSA SL-K Light Carbon, BB30, 53/39 (Option: compact 50/34)
<b>Bottom Bracket</b>	FSA BB30	FSA BB30	SRAM BB30	FSA BB30	FSA BB30
<b>Chain</b>	Shimano Ultegra 6700	Shimano Ultegra 6700	KMC DX10SC	Shimano 105 5700	Shimano Ultegra 6700
<b>Rear Cogs</b>	Shimano Ultegra 6700, 11-25	Shimano Ultegra 6700, 11-25	SRAM PG-1070, 11-26	Shimano 105 5700, 11-25	Shimano Ultegra 6700, 11-25
<b>Front Derailleur</b>	Shimano Dura-Ace 7900, 34.9 mm clamp	Shimano Ultegra 6700, 34.9 mm clamp	SRAM Rival, 34.9 mm clamp	Shimano 105 5700, 34.9 mm clamp	Shimano Ultegra 6700 braze-on
<b>Rear Derailleur</b>	Shimano Dura-Ace 7900	Shimano Ultegra 6700	SRAM Rival	Shimano 105 5700	Shimano Dura-Ace 7900
<b>Shifters</b>	Shimano Dura-Ace 7900	Shimano Ultegra 6700	SRAM Rival	Shimano 105 5700	Shimano Dura-Ace 7900
<b>Handlebar</b>	FSA Wing Pro Compact	Cannondale C2 Compact	Cannondale C2 Compact	Cannondale C2 Compact	Cannondale C2 Compact
<b>Stem</b>	FSA SLK 31.8	Cannondale C2, 31.8	Cannondale C2, 31.8	Cannondale C2, 31.8	Cannondale C2, 31.8
<b>Headset</b>	SuperSix, 1.5 lower bearing, 30 mm carbon, w/5 mm hidden alloy top cover	SuperSix, 1.5 lower bearing, 30 mm carbon, w/5 mm hidden alloy top cover	SuperSix, 1.5 lower bearing, 30 mm carbon, w/5 mm hidden alloy top cover	SuperSix, 1.5 lower bearing, 30 mm alloy, w/5 mm hidden top cover	CAAD10, 1-1/4" lower bearing, 25 mm carbon top cap
<b>Brakes</b>	Shimano Ultegra 6700	Tektro R580, dual pivot, cartridge pad	SRAM dual pivot	Tektro R580, dual pivot, cartridge pad	Shimano Ultegra 6700
<b>Brake Levers</b>	Shimano Ultegra 6700	Shimano Ultegra 6700	SRAM Rival	Shimano 105 5700	Shimano Dura-Ace 7900
<b>Saddle</b>	Fi'zi:k Arione Mg rails	Fi'zi:k Arione Mg rails	Prologo Scratch Pro T2.0	Prologo Kappa Pas	Fi'zi:k Arione Mg rails
<b>Seatpost</b>	FSA SLK Carbon SP-RK-260, 31.6 mm, 350 mm	Cannondale C2, UD Carbon, 31.6 mm, 300 mm	Cannondale C2, UD Carbon, 31.6 mm, 300 mm	Cannondale C2, UD Carbon, 31.6 mm, 300 mm	Cannondale C2, UD Carbon, 27.2 mm, 300 mm
<b>Sizes</b>	48, 50, 52, 54, 56, 58, 60, 63cm	48, 50, 52, 54, 56, 58, 60, 63cm	48, 50, 52, 54, 56, 58, 60, 63cm	48, 50, 52, 54, 56, 58, 60, 63cm	48, 50, 52, 54, 56, 58, 60, 63cm
<b>Color 1 (code)</b>	Jet Black Matte w/outline decals (matte) (BLK).	Blue Tinted Clear Coat (gloss) (BLU).	Jet Black Matte w/outline decals (matte) (BLK).	Exposed Carbon (matte) (CRB).	Black Anodized (matte) (BLA).
<b>Color 2 (code)</b>	Magnesium White, Race Red (gloss) (RED).	Race Red (gloss) (RED).	Magnesium White and Orange (gloss) (ORG).	Team Replica (gloss) (REP).	Race Red (gloss) (RED).
<b>Extras</b>					

	<b>CAAD10 3 ULTEGRA</b>	<b>CAAD10 4 RIVAL</b>	<b>CAAD10 5 105</b>	<b>CAAD8 5 105</b>	<b>CAAD8 6 TIAGRA</b>
<b>Code</b>	1RAX3D, 1RAX3C	1RAX4D, 1RAX4C	1RAX5D, 1RAX5C	1RA85C, 1RA85T	1RA86C, 1RA86T
<b>Frame</b>	CAAD10, Smartformed 6069 Alloy, SAVE, BB30	CAAD10, Smartformed 6069 Alloy, SAVE, BB30	CAAD10, Smartformed 6069 Alloy, SAVE, BB30	CAAD8, Optimized 6061 Alloy, BB30	CAAD8, Optimized 6061 Alloy
<b>Fork</b>	CAAD10, full carbon, 1-1/8" to 1-1/4" tapered steerer	CAAD10, full carbon, 1-1/8" to 1-1/4" tapered steerer	CAAD10, full carbon, 1-1/8" to 1-1/4" tapered steerer	Cannondale Ultra, Carbon Blades, 1-1/8"	Cannondale Ultra, Carbon Blades, 1-1/8"
<b>Rims</b>	Mavic Aksium	Shimano RS10	Shimano RS10	Alex RC24	Maddux DRX 4000
<b>Hubs</b>	Mavic Aksium	Shimano RS10	Shimano RS10	Formula RB-51, 28 hole front, RB-52, 32 hole rear	Formula RB-51, 32 hole front, RB-52, 32 hole rear
<b>Spokes</b>	Mavic Aksium	Shimano RS10	Shimano RS10	Stainless Steel, bladed	Stainless Steel
<b>Tires</b>	Schwalbe Lugano, 700 x 23c, folding	Schwalbe Lugano, 700 x 23c, folding	Schwalbe Lugano, 700 x 23c, folding	Schwalbe Lugano, 700 x 23c	Schwalbe Lugano, 700 x 23c
<b>Pedals</b>	N/A	N/A	N/A	N/A	N/A
<b>Crank</b>	FSA SL-K Light Carbon, BB30, 53/39 (Option: compact 50/34)	SRAM Force Carbon, BB30, 53/39 (Option: compact 50/34)	FSA Gossamer Pro, BB30, 53/39 (Option: compact 50/34)	FSA Gossamer, BB30, 50/34 (Option: triple 50/39/30)	FSA Omega MegaExo, 50/34 (Option: triple 50/39/30)
<b>Bottom Bracket</b>	FSA BB30	SRAM BB30	FSA BB30	FSA BB30	FSA MegaExo
<b>Chain</b>	Shimano Ultegra 6700	KMC DX10SC	Shimano 105 5700	Shimano 105 5700	KMC 9-speed
<b>Rear Cogs</b>	Shimano Ultegra 6700, 11-25	SRAM PG-1070, 11-26	Shimano 105 5700, 12-27	Shimano 105 5700, 12-27	SRAM PG-950, 12-26
<b>Front Derailleur</b>	Shimano Ultegra 6700 braze-on	SRAM Rival, braze-on	Shimano 105 5700, braze-on	Shimano 105 5700, 34.9 mm clamp	Shimano Tiagra, 34.9 clamp
<b>Rear Derailleur</b>	Shimano Ultegra 6700	SRAM Rival	Shimano 105 5700	Shimano 105 5700	Shimano Tiagra
<b>Shifters</b>	Shimano Ultegra 6700	SRAM Rival	Shimano 105 5700	Shimano 105 5700	Shimano Tiagra
<b>Handlebar</b>	Cannondale C3 Compact	Cannondale C3 Compact	Cannondale C3 Compact	Cannondale C3 Compact	Cannondale C4 Compact
<b>Stem</b>	Cannondale C3, 31.8	Cannondale C3, 31.8	Cannondale C3, 31.8	Cannondale C3, 31.8	Cannondale C4, 31.8
<b>Headset</b>	CAAD10, 1-1/4" lower bearing, 25 mm carbon top cap	CAAD10, 1-1/4" lower bearing, 25 mm carbon top cap	CAAD10, 1-1/4" lower bearing, 25 mm carbon top cap	CAAD10, 1-1/4" lower bearing, 25 mm carbon top cap	CAAD10, 1-1/4" lower bearing, 25 mm carbon top cap
<b>Brakes</b>	Tektro R580, dual pivot, cartridge pad	SRAM dual pivot	Shimano 105 5700	Tektro R580, dual pivot, cartridge pad	Cannondale C4 w/cartridge pads and cold forged retainer
<b>Brake Levers</b>	Shimano Ultegra 6700	SRAM Rival	Shimano 105	Shimano 105 5700	Shimano Tiagra
<b>Saddle</b>	Prologo Scratch Pro T2.0	Prologo Kappa Pas	Prologo Kappa Pas	Cannondale Stage w/Crmo Rails	Cannondale Stage w/Steel Rails
<b>Seatpost</b>	Cannondale C2, UD Carbon, 27.2 mm, 300 mm	Cannondale C2, UD Carbon, 31.6 mm, 300 mm	Cannondale C3, Carbon wrap, 27.2 mm, 300 mm	Cannondale C3, Carbon wrap, 31.6 mm, 300 mm	Cannondale C4 alloy, 31.6 mm, 300 mm
<b>Sizes</b>	48, 50, 52, 54, 56, 58, 60, 63cm	48, 50, 52, 54, 56, 58, 60, 63cm	48, 50, 52, 54, 56, 58, 60, 63cm	48, 51, 54, 56, 58, 61cm	48, 51, 54, 56, 58, 61cm
<b>Color 1 (code)</b>	Berserker Green (gloss) (GRN).	Jet Black, Magnesium White (gloss) (BLK).	Jet Black (gloss) (BLK).	Jet Black (gloss) (BLK).	Jet Black (matte) (BBQ).
<b>Color 2 (code)</b>	Magnesium White (gloss) (WHT).	Magnesium White, Indigo Blue (gloss) (BLU).	Race Red (gloss) (RED).	Magnesium White w/Race Red (gloss) (WHT).	Magnesium White w/Indigo Blue (gloss) (WHT).
<b>Extras</b>					

	<b>CAAD8 7 SORA</b>	<b>SYNAPSE HI-MOD 1 DURA-ACE</b>	<b>SYNAPSE HI-MOD 2 SRAM RED</b>	<b>SYNAPSE CARBON 3 ULTEGRA</b>	<b>SYNAPSE CARBON 4 RIVAL</b>
<b>Code</b>	1RA87C, 1RA87T	1RCL1C	1RCL2C	1RCS3C, 1RCS3T	1RCS4C
<b>Frame</b>	CAAD8, Optimized 6061 Alloy	Synapse, HI-MOD full carbon, SAVE, BB30	Synapse, HI-MOD full carbon, SAVE, BB30	Synapse, full carbon, SAVE, BB30	Synapse, full carbon, SAVE, BB30
<b>Fork</b>	Cannondale Ultra, Carbon Blades, 1-1/8"	Synapse, HI-MOD full carbon, SAVE, 1-1/8"	Synapse, HI-MOD full carbon, SAVE, 1-1/8"	Synapse, full carbon, SAVE, 1-1/8", alloy dropouts	Synapse, full carbon, SAVE, 1-1/8", alloy dropouts
<b>Rims</b>	Maddux DRX 4000	Mavic Ksyrium SL, black	Mavic Ksyrium Elite	DT Swiss R-1700	Mavic Aksium
<b>Hubs</b>	Formula RB-51 front, RB-52 rear, 32 hole	Mavic Ksyrium SL, black	Mavic Ksyrium Elite	DT Swiss R-1700	Mavic Aksium
<b>Spokes</b>	Stainless Steel	Mavic Ksyrium SL, black	Mavic Ksyrium Elite	DT Swiss R-1700	Mavic Aksium
<b>Tires</b>	Schwalbe Lugano, 700 x 23c	Schwalbe Ultremo ZX, 700 x 25c, folding	Schwalbe Ultremo ZX, 700 x 25c, folding	Schwalbe Durano 700 x 25c, folding	Schwalbe Durano, 700 x 25c, folding
<b>Pedals</b>	N/A	N/A	N/A	N/A	N/A
<b>Crank</b>	FSA Vero, 50/34 (Option: triple 50/39/30)	Cannondale Hollowgram SL BB30, 50/34, FSA DA-79 chainrings	SRAM RED w/Cannondale graphics, BB30, 50/34	FSA SL-K Light Carbon, BB30, 50/34 (Option: triple 52/39/30)	FSA Gossamer Pro BB30, 50/34
<b>Bottom Bracket</b>	FSA	Cannondale BB30, ceramic bearings	SRAM RED, BB30	FSA BB30	FSA BB30
<b>Chain</b>	KMC 9-speed	Shimano Dura-Ace 7900	KMC X10 SL	Shimano Ultegra 6700	KMC DX10SC
<b>Rear Cogs</b>	SRAM PG-950, 12-26	Shimano Dura-Ace 7900, 11-28	SRAM PG-1070, 11-28	Shimano Ultegra 6700, 11-28	SRAM PG-1070, 11-28
<b>Front Derailleur</b>	Shimano Sora, 34.9 clamp	Shimano Dura-Ace 7900 braze-on	SRAM RED, Braze On	Shimano Ultegra 6700, braze-on	SRAM Rival, braze-on
<b>Rear Derailleur</b>	Shimano Sora	Shimano Dura-Ace 7900	SRAM RED	Shimano Ultegra 6700	SRAM Rival
<b>Shifters</b>	Shimano Sora	Shimano Dura-Ace 7900	SRAM RED	Shimano Ultegra 6700	SRAM Rival
<b>Handlebar</b>	Cannondale C4 Compact	FSA SL-K Compact	FSA Wing Pro Compact	FSA Wing Compact	FSA Wing Compact
<b>Stem</b>	Cannondale C4, 31.8 mm	FSA SLK, 31.8	FSA SLK, 31.8	FSA OS-150, 31.8	Cannondale C2, 31.8
<b>Headset</b>	CAAD10, 1-1/4" lower bearing, 25 mm carbon top cap	Synapse Si, 25 mm carbon top cap	Synapse Si, 25 mm carbon top cap	Synapse Si, 25 mm carbon top cap	Synapse Si, 25 mm top cap
<b>Brakes</b>	Cannondale C4 w/cartridge pads and cold forged retainer	Shimano Dura-Ace 7900	SRAM RED	Shimano Ultegra 6700	SRAM dual pivot
<b>Brake Levers</b>	Shimano Sora	Shimano Dura-Ace 7900	SRAM RED	Shimano Ultegra 6700	SRAM Rival
<b>Saddle</b>	Cannondale Stage w/Steel Rails	Fi'zi:k Aliante Gamma w/Kium rails	Fi'zi:k Aliante Delta Mg rails	Fi'zi:k Aliante Delta Mg rails	Prologo Scratch Pro T2.0
<b>Seatpost</b>	Cannondale C4 alloy, 31.6 mm, 300 mm	Synapse SAVE HI-MOD, 275 mm	Synapse SAVE HI-MOD, 275 mm	Synapse SAVE carbon, 275 mm	Synapse SAVE carbon, 275 mm
<b>Sizes</b>	48, 51, 54, 56, 58, 61cm	48, 51, 54, 56, 58, 61cm	48, 51, 54, 56, 58, 61cm	48, 51, 54, 56, 58, 61cm	48, 51, 54, 56, 58, 61cm
<b>Color 1 (code)</b>	Race Red w/White (gloss) (RED).	Exposed Carbon (matte) (CRB).	Exposed Carbon (matte) (CRB).	Charcoal Grey w/Magnesium White (gloss) (GRY).	Indigo Blue (gloss) (BLU).
<b>Color 2 (code)</b>	Magnesium White w/Charcoal Grey (gloss) (WHT).	Magnesium White w/Race Red (gloss) (WHT).	Magnesium White w/Race Red (gloss) (WHT).	Race Red w/Magnesium White (gloss) (RED).	Race Red w/Magnesium White (gloss) (RED).
<b>Extras</b>					

	<b>SYNAPSE CARBON 5 105</b>	<b>SYNAPSE CARBON 6 APEX</b>	<b>SYNAPSE ALLOY 5 105</b>	<b>SYNAPSE ALLOY 6 TIAGRA</b>	<b>SYNAPSE ALLOY 7 SORA</b>
<b>Code</b>	1RCS5C, 1RCS5T	1RCS6C	1RAS5C, 1RAS5T	1RAS6C, 1RAS6T	1RAS7T
<b>Frame</b>	Synapse, full carbon, SAVE, BB30	Synapse Carbon, BB30	Synapse, Optimized 6061 Alloy, BB30, SAVE	Synapse, Optimized 6061 Alloy, SAVE	Synapse, Optimized 6061 Alloy, SAVE
<b>Fork</b>	Synapse, full carbon, SAVE, 1-1/8", alloy dropouts	Synapse SAVE, full carbon, alloy dropouts	Synapse SAVE, carbon blades, 1-1/8"	Synapse SAVE, carbon blades, 1-1/8"	Synapse SAVE, carbon blades, 1-1/8"
<b>Rims</b>	Shimano RS10	Shimano R500A	Shimano RS10	Maddux DRX 4000	Maddux DRX 4000
<b>Hubs</b>	Shimano RS10	Shimano R500A	Shimano RS10	Formula RB-51 front, RB-52 rear, 32 hole	Formula RB-51 front, RB-52 rear, 32 hole
<b>Spokes</b>	Shimano RS10	Shimano R500A	Shimano RS10	Stainless Steel	Stainless Steel
<b>Tires</b>	Schwalbe Lugano, 700 x 25c, folding	Schwalbe Lugano, 700 x 25c, folding	Schwalbe Lugano, 700 x 25c	Schwalbe Lugano, 700 x 25c	Schwalbe Lugano, 700 x 25c
<b>Pedals</b>	N/A	N/A	N/A	N/A	N/A
<b>Crank</b>	FSA Gossamer Pro, BB30, 50/34 (Option: triple 52/39/30)	SRAM S150 Compact, 50/34	FSA Gossamer, BB30, 50/34 (Option: triple 50/39/30)	FSA Omega MegaExo, 50/34 (Option: triple 50/39/30)	FSA Vero, 50/39/30
<b>Bottom Bracket</b>	FSA BB30	SRAM Powerspline w/BB30 adaptor	FSA BB30	FSA MegaExo	FSA
<b>Chain</b>	Shimano 105 5700	KMC DX-10	Shimano 105 5700	KMC 9-speed	KMC 9-speed
<b>Rear Cogs</b>	Shimano 105 5700, 12-25	SRAM Apex, 11-32	Shimano 105 5700, 11-28	SRAM PG-950, 12-26	SRAM PG-950, 12-26
<b>Front Derailleur</b>	Shimano 105 5700, braze-on	SRAM Apex, braze-on	Shimano 105 5700, 34.9 mm clamp	Shimano Tiagra	Shimano Sora
<b>Rear Derailleur</b>	Shimano 105 5700	SRAM Apex WIFLi	Shimano 105 5700	Shimano Tiagra	Shimano Sora
<b>Shifters</b>	Shimano 105 5700	SRAM Apex	Shimano 105 5700	Shimano Tiagra	Shimano Sora
<b>Handlebar</b>	FSA Wing Compact	FSA Wing Compact	Cannondale C3 Compact	Cannondale C4 Compact	Cannondale C4 Compact
<b>Stem</b>	Cannondale C2, 31.8	Cannondale C3, 31.8	Cannondale C3, 31.8	Cannondale C4, 31.8	Cannondale C4, 31.8
<b>Headset</b>	Synapse Si, 25 mm top cap	Synapse Si, 25 mm top cap	Synapse Si, 25 mm top cap	Synapse Si, 25 mm top cap	Synapse Si, 25 mm top cap
<b>Brakes</b>	Tektro R580, dual pivot, cartridge pad	SRAM Apex	Tektro R580, dual pivot, cartridge pad long reach	Cannondale C4 w/cartridge pads, long reach	Cannondale C4 w/cartridge pads, long reach
<b>Brake Levers</b>	Shimano 105 5700	SRAM Apex	Shimano 105 5700	Shimano Tiagra	Shimano Sora
<b>Saddle</b>	Prologo Kappa Pas	Cannondale Stage w/Crmo Rails	Cannondale Stage w/Crmo Rails	Cannondale Stage w/Steel Rails	Cannondale Stage w/Steel Rails
<b>Seatpost</b>	Synapse SAVE carbon, 275 mm	Synapse SAVE carbon, 275 mm	Cannondale C3, carbon wrapped, 27.2 mm, 300 mm	Cannondale C4, alloy, 27.2 mm, 300 mm	Cannondale C4, alloy, 27.2 mm, 300 mm
<b>Sizes</b>	48, 51, 54, 56, 58, 61cm	48, 51, 54, 56, 58, 61cm	48, 51, 54, 56, 58, 61cm	48, 51, 54, 56, 58, 61cm	48, 51, 54, 56, 58, 61cm
<b>Color 1 (code)</b>	Jet Black (gloss) (BLK).	Indigo Blue (gloss) (BLU).	Jet Black w/White (gloss) (BLK).	Indigo Blue w/White (gloss) (BLU).	Jet Black w/White (gloss) (BLK).
<b>Color 2 (code)</b>	Berserker Green (gloss) (GRN).	Charcoal Grey (matte) (GRY).	Magnesium White w/Indigo Blue (gloss) (WHT).	Magnesium White w/Race red (gloss) (WHT).	Race Red w/White (gloss) (RED).
<b>Extras</b>					

	<b>SLICE HI-MOD SRAM RED</b>	<b>SLICE 3 ULTEGRA</b>	<b>SLICE 4 RIVAL</b>	<b>SLICE 5 105</b>	<b>SUPERX SRAM RED</b>
<b>Code</b>	1RM2D	1RM3D	1RM4D	1RM5D	1XR00C
<b>Frame</b>	Slice, Hi-MOD full carbon, SAVE, BB30	Slice, full carbon, SAVE, BB30	Slice, full carbon, SAVE, BB30	Slice, full carbon, SAVE, BB30	SuperX, BallisTec Hi-MOD full carbon, SAVE, BB30
<b>Fork</b>	Slice Aero, Hi-MOD full carbon, 1-1/8"	Slice Aero, full carbon, 1-1/8"	Slice Aero, full carbon, 1-1/8"	Slice Aero, full carbon, 1-1/8"	Supex, BallisTec Hi-MOD full carbon, 1-1/8" to 1-1/4" tapered steerer
<b>Rims</b>	Mavic Cosmic Carbone SL	Mavic Cosmic Elite	Fulcrum Racing 7	Shimano R500A	ZIPP 303 Cyclocross Tubular
<b>Hubs</b>	Mavic Cosmic Carbone SL	Mavic Cosmic Elite	Fulcrum Racing 7	Shimano R500A	ZIPP 303 Cyclocross Tubular
<b>Spokes</b>	Mavic Cosmic Carbone SL	Mavic Cosmic Elite	Fulcrum Racing 7	Shimano R500A	ZIPP 303 Cyclocross Tubular
<b>Tires</b>	Schwalbe Ultrero ZX, 700 x 23c	Schwalbe Durano S, 700 x 23c, folding	Schwalbe Lugano, 700 x 23c, folding	Schwalbe Lugano, 700 x 23c, folding	Vittoria EVO XM Cross Tubular
<b>Pedals</b>	N/A	N/A	N/A	N/A	N/A
<b>Crank</b>	Cannondale Hollowgram SL BB30, 53/39 w/Aero Spider and SRAM TT rings	Vision TriMax Carbon TT BB30, 53/39	FSA Trimax Pro BB30, 52/38	FSA Gossamer Pro BB30, 53/39	FSA SL-K Light Carbon BB30, 46/36
<b>Bottom Bracket</b>	Cannondale BB30	FSA BB30	FSA BB30	FSA BB30	FSA BB30
<b>Chain</b>	SRAM PC-1070	Shimano Ultegra 6700	KMC DX10	Shimano 105 5700	KMC X10SL
<b>Rear Cogs</b>	SRAM PG-1070, 12-26	Shimano Ultegra 6700, 12-25	SRAM PG-1070, 12-25	Shimano 105 5700, 12-25	SRAM PG-1070, 12-26
<b>Front Derailleur</b>	SRAM RED, braze-on	Shimano Ultegra 6700, braze-on	SRAM Rival, braze-on	Shimano 105 5700, braze-on	SRAM RED, braze-on
<b>Rear Derailleur</b>	SRAM RED	Shimano Ultegra 6700	SRAM Rival	Shimano 105 5700	SRAM RED
<b>Shifters</b>	SRAM 1090 R2C	Shimano Ultegra 6700	SRAM 1090 R2C	Microshift Shimano-compatible bar-end	SRAM RED
<b>Handlebar</b>	FSA Vision OS Carbon Base Bar w/Vision Vector Carbon Extensions	FSA Vision OS Alloy Base Bar w/Vision Vector Carbon Extensions	Cannondale C3 Aero bar, 31.8, w/Profile T2 Carbon clip-ons	Cannondale C3 Aero bar, 31.8, w/Profile T2 clip-ons	FSA Energy
<b>Stem</b>	FSA SLK, 31.8	Cannondale C2, 31.8	Cannondale C3, 31.8	Cannondale C3, 31.8	FSA SLK, 31.8
<b>Headset</b>	Slice, Si, 8 mm carbon top cap	Slice, Si, 15 mm top cap	Slice, Si, 15 mm top cap	Slice, Si, 15 mm top cap	Cannondale SuperX, 1 1/8"
<b>Brakes</b>	SRAM RED	Shimano Ultegra 6700	SRAM Dual Pivot	Tektro R520	FSA SLK
<b>Brake Levers</b>	FSA BL Aero	FSA BL Aero	Alloy aero levers	Alloy aero levers	SRAM RED
<b>Saddle</b>	Fi'zi:k Arione TRI2 w/Kium rails	Fi'zi:k Arione TRI2, Mg Rails	Fi'zi:k Arione TRI2, Mg Rails	Fi'zi:k Arione TRI2, Mg Rails	Fi'zi:k Tundra 2, Kium Rails
<b>Seatpost</b>	Cannondale Slice Carbon Aero Hi-MOD, 2 position, 350 mm	Cannondale Slice Carbon Aero, 2 position, 350 mm	Cannondale Slice Carbon Aero, 2 position, 350 mm	Cannondale Slice Carbon Aero, 2 position, 350 mm	FSA SLK, 27.2 mm, 350 mm
<b>Sizes</b>	51, 54, 56, 58, 60cm	51, 54, 56, 58, 60cm	51, 54, 56, 58, 60cm	51, 54, 56, 58, 60cm	44, 48, 52, 54, 56, 58cm
<b>Color 1 (code)</b>	Jet Black (matte) (BBQ).	Magnesium White (gloss) (WHT).	Magnesium White (gloss) (WHT).	Magnesium White (gloss) (WHT).	Berserker Green (gloss) (GRN).
<b>Color 2 (code)</b>					
<b>Extras</b>					

	<b>SUPERX SRAM RIVAL</b>	<b>CAADX SRAM RIVAL</b>	<b>CAADX 105</b>	<b>CAADX TIAGRA</b>	<b>QUICK CARBON 1</b>
<b>Code</b>	1XC4C	1XR4C	1XR5C	1XR6C, 1XR6T	0QRCLC
<b>Frame</b>	SuperX, BallisTec Hi-MOD full carbon, SAVE, BB30	CAADX Cyclocross, Optimized 6061 Alloy, BB30	CAADX Cyclocross, Optimized 6061 Alloy, BB30	CAADX Cyclocross, Optimized 6061 Alloy	Quick, full carbon, BB30 Si
<b>Fork</b>	SuperX, BallisTec Hi-MOD full carbon, 1-1/8" to 1-1/4" tapered steerer	Cannondale Ultra X, carbon blades, 1-1/8"	Cannondale Ultra X, carbon blades, 1-1/8"	Cannondale Ultra X, carbon blades, 1-1/8"	Quick, full carbon, Si, 1-1/8" steerer
<b>Rims</b>	Mavic Ksyrium Equipe	Maddux DRX 6000	Maddux DRX 6000	Maddux DRX 6000	Formula XERO Element CXR
<b>Hubs</b>	Mavic Ksyrium Equipe	Formula RB-91 front, RB-32 rear, 32 hole	Formula RB-51 front, RB-52 rear, 32 hole	Formula RB-51 front, RB-52 rear, 32 hole	Formula XERO Element CXR
<b>Spokes</b>	Mavic Ksyrium Equipe	Stainless Steel XD Black	Stainless Steel XD Black	Stainless Steel XD Black	Formula XERO Element CXR
<b>Tires</b>	Continental CX RACE, 700 X 35c	Continental Cyclocross Speed, 700 x 35c	Continental Cyclocross Speed, 700 x 35c	Continental Cyclocross Speed, 700 x 35c	Kenda Kwick Roller Sport, 700 X 28c
<b>Pedals</b>	N/A	Wellgo Composite body Alloy Cage	Wellgo Composite body Alloy Cage	Wellgo Composite body Alloy Cage	Wellgo alloy cage
<b>Crank</b>	FSA SL-K Light Carbon BB30, 46/36	FSA SL-K Light Carbon BB30, 46/36	FSA Gossamer BB30, 46/36	FSA Omega Mega Exo, 46/36, Option: FSA Omega Mega Exo, 50/39/30	FSA SLK BB30 Compact MegaExo, 50/34
<b>Bottom Bracket</b>	FSA BB30	FSA BB30	FSA BB30	FSA Mega Exo	FSA BB30
<b>Chain</b>	KMC X10	KMC X10	Shimano 105 5700	Shimano HG-53	KMC X10SL, 10-speed
<b>Rear Cogs</b>	SRAM PG 1070, 12-27	SRAM PG 1070, 12-27	Shimano 105 5700, 12-25	SRAM PG 950, 12-26	SRAM PG-1070, 12-27
<b>Front Derailleur</b>	SRAM Rival, braze on	SRAM Rival, 34.9 mm clamp	Shimano 105 5700, braze-on	Shimano Tiagra, 34.9 mm clamp	Shimano 105, braze-on
<b>Rear Derailleur</b>	SRAM Rival	SRAM Rival	Shimano 105 5700	Shimano Tiagra Triple	Shimano Ultegra 6700
<b>Shifters</b>	SRAM Rival	SRAM Rival	Shimano 105 5700	Shimano Tiagra	Shimano SL-R770, 10-speed
<b>Handlebar</b>	FSA Energy	ControlTech Elite	ControlTech Elite	ControlTech Elite	Cannondale C3, butted 6061 alloy, 20 mm rise
<b>Stem</b>	Cannondale C2, 31.8	Cannondale C3, 31.8	Cannondale C4, 31.8	Cannondale C4, 31.8	Cannondale C3, 31.8
<b>Headset</b>	Cannondale SuperX, 1 1/8"	CAADX, Si, 1 1/8"	CAADX, Si, 1 1/8"	CAADX, Si, 1 1/8"	Tange Integrated w/25 mm top cover
<b>Brakes</b>	FSA SLK	TRP EuroX	Tektro CR720, black	Tektro CR520, silver	Tektro Mini-V w/cartridge pads
<b>Brake Levers</b>	SRAM Rival	SRAM Rival	Shimano 105 5700	Shimano Tiagra	Tektro 3-finger
<b>Saddle</b>	Fi'zi:k Tundra 2, Mg Rails	Cannondale w/Crmo Rails	Cannondale w/Crmo Rails	Cannondale w/Crmo Rails	Cannondale Quick Ergo High Performance
<b>Seatpost</b>	Cannondale C2, UD Carbon, 27.2 mm, 300 mm	Cannondale C3, Alloy, 31.6 mm, 300 mm	Cannondale C3, Alloy, 31.6 mm, 300 mm	Cannondale C3, Alloy, 31.6 mm, 300 mm	SAVE full carbon
<b>Sizes</b>	44, 48, 52, 54, 56, 58cm	44, 48, 51, 54, 56, 58, 61cm	44, 48, 51, 54, 56, 58, 61cm	44, 48, 51, 54, 56, 58, 61cm	S, M, L, X, J
<b>Color 1 (code)</b>	Berserker Green (gloss) (GRN).	Race Red (gloss) (RED).	Brushed Aluminum (RAW).	Jet Black (matte) (BBQ).	Uni-directional Carbon (matte) (CRB).
<b>Color 2 (code)</b>					
<b>Extras</b>					Cannondale Lock On Ergo grips

<b>QUICK CARBON 2</b>		<b>QUICK 1</b>		<b>QUICK 2</b>		<b>QUICK 3</b>		<b>QUICK 4</b>	
<b>Code</b>	QORC2T		1QR1		1QR2		1QR3		1QR4
<b>Frame</b>	Quick, full carbon, BB30 Si		Quick SL, Optimized 6061 Alloy, SAVE		Quick SL, Optimized 6061 Alloy, SAVE		Quick SL, Optimized 6061 Alloy, SAVE		Quick, butted 6061 alloy, SAVE
<b>Fork</b>	Quick, full carbon, Si, 1-1/8" steerer		Quick, carbon blades, 1 1/8" steerer		Quick, carbon blades, 1 1/8" steerer		Quick, carbon blades, 1 1/8" steerer		Quick, carbon blades, 1 1/8" steerer
<b>Rims</b>	Formula XERO Element CXR		Element Xero C2		Element Xero C3		Element Xero C3		Element Xero C3
<b>Hubs</b>	Formula XERO Element CXR		Element Xero C2		Element Xero C3		Element Xero C3		Element Xero C3
<b>Spokes</b>	Formula XERO Element CXR		Element Xero Bladed Stainless		Element Xero Stainless		Element Xero Stainless		Element Xero Stainless
<b>Tires</b>	Kenda Kwick Roller Sport, 700 X 28c		Continental Sport Contact, 700 x 32c		Continental Sport Contact, 700 x 32c		Continental City Contact, 700 x 32c		Kenda Kwick Trax, 700 X 38c
<b>Pedals</b>	Wellgo alloy cage		Quick Alloy w/Kraton, by Wellgo		Quick Alloy w/Kraton, by Wellgo		Quick Alloy w/Kraton, by Wellgo		Quick Reinforced Composite w/Kraton, by Wellgo
<b>Crank</b>	FSA Gossamer BB30 Triple, 52/39/30		Shimano 105 triple, 50/39/30		Shimano Tiagra triple, 50/39/30		Shimano M431, 48/36/26		Shimano M131, 48/38/28
<b>Bottom Bracket</b>	FSA BB30		Shimano 105		Shimano Tiagra		Tange Cartridge		Tange Cartridge
<b>Chain</b>	KMC X10SL, 10-speed		KMC X10, 10-speed		KMC Z99, 9-speed		KMC Z99, 9-speed		KMC Z72, 8-speed
<b>Rear Cogs</b>	SRAM PG-1070, 12-27		Shimano 105, 12-27		SRAM PG-950, 12-26		SRAM PG-950, 12-26		SunRace CSM668, 11-32
<b>Front Derailleur</b>	Shimano 105, braze-on		Shimano R773		Shimano R443		Shimano Alivio M431		Shimano M191
<b>Rear Derailleur</b>	Shimano 105		Shimano 105		Shimano Tiagra		Shimano Deore M591		Shimano Alivio M410
<b>Shifters</b>	Shimano SL-R770, 10-speed		Shimano SL-R770, 10-speed		Shimano SL-R440, 9-speed		Shimano Alivio M430, 9-speed		Shimano Alivio M410, 8-speed
<b>Handlebar</b>	Cannondale C3, butted 6061 alloy, 20 mm rise		Cannondale C3, butted 6061 alloy, 25 mm rise		Cannondale C3, butted 6061 alloy, 25 mm rise		Cannondale C4, 6061 alloy, 25 mm rise		Cannondale C4, 6061 alloy, 25 mm rise
<b>Stem</b>	Cannondale C3, 31.8		Cannondale C3, 31.8		Cannondale C3, 31.8		Cannondale C4, 31.8		Cannondale C4, 31.8
<b>Headset</b>	Tange Integrated w/25 mm top cover		Tange Custom Si		Tange Custom Si		Tange Custom Si		Tange Custom Si
<b>Brakes</b>	Tektro Mini-V w/cartridge pads		Tektro RX5 Mini V-Brakes		Tektro RX5 Mini V-Brakes		Tektro RX1 Mini V-Brakes		Tektro TX 120 V-Brakes
<b>Brake Levers</b>	Tektro 3-finger		Tektro MT5.0 Carbon		Tektro R392A w/Kraton insert		Tektro R392A w/Kraton insert		Tektro R392A w/Kraton insert
<b>Saddle</b>	Cannondale Quick Ergo High Performance		Cannondale Quick Ergo Performance		Cannondale Quick Ergo Performance		Cannondale Quick Ergo Performance		Cannondale Quick Ergo Performance
<b>Seatpost</b>	SAVE full carbon		Cannondale C2 2014 Alloy, 2 bolt, 27.2 mm		Cannondale C3 6061 Alloy, 2 bolt, 27.2 mm		Cannondale C4 6061 Alloy, 27.2 mm		Cannondale C4 6061 Alloy, 27.2 mm
<b>Sizes</b>	S, M, L, X, J		S, M, L, X, J		XS (26"), S, M, L, X, J		S, M, L, X, J		XS (26"), S, M, L, X, J
<b>Color 1 (code)</b>	Uni-directional Carbon (matte) (CRB).		Brushed Aluminum (gloss) (RAW).		Jet Black (gloss) (BLK).		Indigo Blue (gloss) (BLU).		Jet Black (gloss) (BLK).
<b>Color 2 (code)</b>							Magnesium White (gloss) (WHT).		Charcoal Grey (gloss) (GRY).
<b>Extras</b>	Cannondale Lock On Ergo grips		Cannondale Lock On Ergo Performance grips, w/bar ends		Cannondale Lock On Ergo Performance grips		Cannondale Lock On Ergo Performance grips		Cannondale Ergo Performance grips

<b>QUICK 5</b>		<b>QUICK CX 1</b>		<b>QUICK CX 2</b>		<b>QUICK CX 3</b>		<b>QUICK CX 4</b>	
<b>Code</b>	1QR5		1QRX1		1QRX2		1QRX3		1QRX4
<b>Frame</b>	Quick, butted 6061 alloy, SAVE		Quick CX Si, Optimized 6061 Alloy, SAVE, HeadShok		Quick CX, Optimized 6061 Alloy, SAVE, 1.5" head tube		Quick CX, Optimized 6061 Alloy, SAVE, 1.5" head tube		Quick CX Rigid, Optimized 6061 Alloy, SAVE, 1-1/8" Si head tube
<b>Fork</b>	Quick, 6061 Alloy, 1 1/8" steerer		HeadShok Fatty DL50 w/lockout, OPI		RST Neon Pro Custom 1.5" Trekking TnL Lockout, 50 mm		RST Neon Pro Custom 1.5" Trekking ML Lockout, 50 mm		Fatty Rigid Disc
<b>Rims</b>	Jalco DT 21		Element Xero C2		Maddux Disc X320 w/eyelets		Maddux Disc X320 w/eyelets		Maddux Disc X320 w/eyelets
<b>Hubs</b>	Formula RM21 front, FM22 rear		Element Xero C2		Shimano M435 Alivio centerlock disc		Formula DC20 front, DC22 rear		Formula DC20 front, DC22 rear
<b>Spokes</b>	Stainless 15g		Stainless Steel XD Black w/Red Nipples		Stainless Steel XD Black w/Red Nipples		Stainless Steel XD Black w/Red Nipples		Stainless Steel XD Black w/Red Nipples
<b>Tires</b>	Kenda Kwick Trax, 700 X 38c		Continental Double Fighter II, 700 x 37c		Continental Double Fighter II, 700 x 37c		Continental Double Fighter II, 700 x 37c		Continental Double Fighter II, 700 x 37c
<b>Pedals</b>	Quick Reinforced Composite w/Kraton, by Wellgo		Wellgo, Platform type, Reinforced Resin		Wellgo, Platform type, Reinforced Resin		Wellgo, Platform type, Reinforced Resin		Wellgo, Platform type, Reinforced Resin
<b>Crank</b>	Shimano M131, 48/38/28		Shimano M521, 48/36/26		Shimano M431, 48/36/26		Shimano M171, 48/38/28		Shimano M171, 48/38/28
<b>Bottom Bracket</b>	Tange Cartridge		Shimano Octalink		Tange Seiki Cartridge BB		Tange Seiki Cartridge BB		Tange Seiki Cartridge BB
<b>Chain</b>	KMC Z72, 8-speed		Shimano HG-53, 9-speed		Shimano HG-53, 9-speed		KMC-Z82, 8-speed		KMC-Z82, 8-speed
<b>Rear Cogs</b>	SunRace CSM668, 11-32		Shimano-HG30, 11-32		Shimano-HG30, 11-32		Sunrace CSG66, 11-32		Sunrace CSG66, 11-32
<b>Front Derailleur</b>	Shimano M191		Shimano Alivio M431		Shimano Alivio M431		Shimano Alivio M191		Shimano Alivio M191
<b>Rear Derailleur</b>	Shimano Altus M310		Shimano SLX M662 Shadow		Shimano Deore M592 Shadow		Shimano Alivio M410		Shimano Acera M360
<b>Shifters</b>	Shimano Alivio M310, 8-speed		Shimano Deore M590, 9-speed		Shimano Alivio M430, 9-speed		Shimano Acera M360, 8-speed		Shimano Altus M310, 8-speed
<b>Handlebar</b>	Cannondale C4, 6061 alloy, 25 mm rise		Cannondale C3, 6061 butted alloy, 20 mm rise, 600 mm		Cannondale C3, 6061 butted alloy, 20 mm rise, 600 mm		Cannondale C4 6061 alloy, 25 mm rise, 600 mm		Cannondale C4 6061 alloy, 25 mm rise, 600 mm
<b>Stem</b>	Cannondale C4, 31.8		Cannondale C3 HeadShok 3-D Forged		Cannondale C3 1.5" 3-D Forged		Cannondale C3 1.5" 3-D Forged		Cannondale C4
<b>Headset</b>	Tange Custom Si		Tange Custom HeadShok		Tange Custom 1.5"		Tange Custom 1.5"		Tange 1 1/8"
<b>Brakes</b>	Tektro TX 120 V-Brakes		Shimano M505 Hydraulic Disc		Shimano M445 Hydraulic Disc		Tektro Novela Mechanical Disc		Tektro Novela Mechanical Disc
<b>Brake Levers</b>	Cannondale CBL 8.0		Shimano M505 Hydraulic Disc		Shimano M445 Hydraulic Disc		Cannondale CBL 8.0		Cannondale CBL 8.0
<b>Saddle</b>	Cannondale Quick Ergo Performance		Cannondale Quick CX Ergo		Cannondale Quick CX Ergo		Cannondale Quick CX Ergo		Cannondale Quick CX Ergo
<b>Seatpost</b>	Cannondale C4 6061 alloy, 27.2 mm, 350 mm		Cannondale C3, 2 bolt, alloy, 31.6, 350 mm		Cannondale C3, 2 bolt, alloy, 31.6, 350 mm		Cannondale C4, alloy, 31.6, 350 mm		Cannondale C4, alloy, 31.6, 350 mm
<b>Sizes</b>	S, M, L, X, J		S, M, L, X, J		S, M, L, X, J		S, M, L, X, J		S, M, L, X, J
<b>Color 1 (code)</b>	Goodnight Green (matte) (GRN).		Brushed Aluminum (gloss) (RAW).		Race Red (gloss) (RED).		Lightning White (gloss) (WHT).		Jet Black (gloss) (BLK).
<b>Color 2 (code)</b>	Fine Silver (gloss) (SLV).								
<b>Extras</b>	Cannondale Ergo Performance grips		Cannondale Cityscape Urban Lock On grips		Cannondale Cityscape Urban Lock On grips		Cannondale Cityscape Urban Lock On grips		Cannondale Cityscape Urban grips

	<b>ADVENTURE 1</b>	<b>ADVENTURE 2</b>	<b>ADVENTURE 3</b>	<b>ADVENTURE 3 26"</b>	<b>ROAD TANDEM 2</b>
<b>Code</b>	IAS1	IAS2	IAS3	ICS3	9RT2
<b>Frame</b>	Adventure, double butted 6061 alloy	Adventure, double butted 6061 alloy	Adventure, double butted 6061 alloy	Adventure, double butted 6061 alloy,	CAAD Tandem, Optimized 6061 alloy, 700c
<b>Fork</b>	Adventure Trail Si suspension, 35 mm, alloy 1-1/8" steerer	Adventure Trail Si suspension, 35 mm, steel 1-1/8" steerer	RST Sofi T, 50 mm, 1-1/8" steerer	RST Sofi T 26", 50 mm, 1-1/8" steerer	Fatty R Tandem rigid, 1-1/8" steerer
<b>Rims</b>	Cannondale C3, double wall, alloy	Cannondale C3, double wall, alloy	Cannondale C3, double wall, alloy	Cannondale C3, double wall, alloy, 26"	Sun ME14A w/eyelet and machined sidewall, 40 hole
<b>Hubs</b>	Formula FM-21 front, Shimano Nexus Premium 8-speed internal rear	Formula FM-21 front, FM-22 rear	Formula FM-21 front, FM-22 rear	Formula FM-21 front, Formula FM-22 rear	White Industries M16 Disc
<b>Spokes</b>	Stainless, 15g	Stainless, 15g	Stainless, 15g	Stainless, 15g	DT Swiss Champion, 14g
<b>Tires</b>	Kenda Kwik Trax, 700 x 38c	Kenda Kwik Trax, 700 x 38c	Kenda Kwik Trax, 700 x 38c	Kenda NPJ signature, 26 x 1.25"	Continental Ultra GatorSkin, 700 x 28c
<b>Pedals</b>	FPD Resin w/Kraton Insert	FPD Resin w/Kraton Insert	FPD Resin w/Kraton Insert	FPD Resin w/Kraton Insert	N/A
<b>Crank</b>	FSA Single Ring, 38	Shimano M191, 48/38/28	Shimano M191, 48/38/28	Shimano M191, 48/38/28	FSA Gossamer Tandem, 53/39/30
<b>Bottom Bracket</b>	Tange cartridge type	Tange cartridge type	Tange cartridge type	Tange cartridge type	FSA MegaExo
<b>Chain</b>	KMC for single speed	KMC 8-speed	KMC 8-speed	KMC 8-speed	Shimano 105, KMC 8-speed timing
<b>Rear Cogs</b>	N/A	Sunrace CSM668, 11-32	Sunrace CSM668, 11-32	Sunrace CSM668, 11-32	IRD 10-speed, 11-32
<b>Front Derailleur</b>	N/A	Shimano M-191	Shimano M-191	Shimano M-191	Shimano Ultegra 6700
<b>Rear Derailleur</b>	N/A	Shimano Alivio	Shimano Acera	Shimano Acera	Shimano Ultegra 6700
<b>Shifters</b>	Shimano Nexus, twist type, 8-speed	Shimano Revo, twist type, 8-speed	Shimano Revo, twist type, 8-speed	Shimano Revo, twist type, 8-speed	Shimano Ultegra, 10-speed
<b>Handlebar</b>	Cannondale C4, 50 mm rise, alloy	Cannondale C4, 50 mm rise, alloy	Cannondale C4, 50 mm rise, alloy	Cannondale C4, 50 mm rise, alloy	FSA Gossamer, 31.8 front, Stoker rear
<b>Stem</b>	Tranz X Comfort Grip, Tool-free Adjustment	Tranz X Comfort Grip, Tool-free Adjustment	Tranz X Comfort Grip, Tool-free Adjustment, quill type	Tranz X Comfort Grip, Tool-free Adjustment, quill type	Cannondale C3 front, 31.8 Stoker rear
<b>Headset</b>	Tange Integrated	Tange Integrated	Semi-integrated cartridge, threaded	Semi-integrated cartridge, threaded	Tange Integrated
<b>Brakes</b>	Cannondale V Brake w/modulator	Cannondale V Brake w/modulator	Cannondale V Brake w/modulator	Cannondale V Brake w/modulator	Avid BB7 Road Disc
<b>Brake Levers</b>	Shimano Nexus, 4 finger	Cannondale, 4 finger w/Kraton comfort insert	Cannondale, 4 finger w/Kraton comfort insert	Cannondale, 4 finger w/Kraton comfort insert	Shimano Ultegra
<b>Saddle</b>	Cannondale Ultra Comfort	Cannondale Ultra Comfort	Cannondale Ultra Comfort	Cannondale Ultra Comfort	Fi'zi:k Aliante Delta Mg
<b>Seatpost</b>	Cannondale Suspension, 40 mm travel, 27.2, 350 mm	Cannondale Suspension, 40 mm travel, 27.2, 350 mm	Cannondale Suspension, 40 mm travel, 27.2, 350 mm	Cannondale Suspension, 40 mm travel, 27.2, 350 mm	Thomson Elite
<b>Sizes</b>	S, M, L, X, J	S, M, L, X, J	S, M, L, X, J	S, M, L, X, J	MS, LS, XS, JM
<b>Color 1 (code)</b>	Jet Black (gloss) (BLK)	Indigo Blue (gloss) (BLU)	Jet Black (gloss) (BLK)	Jet Black (gloss) (BLK)	Lightning White (gloss) (WHT)
<b>Color 2 (code)</b>		Charcoal Gray (gloss) (GRY)	Goodnight Green (gloss) (GRN)	Goodnight Green (gloss) (GRN)	
<b>Extras</b>	Cannondale Ergo Lock-On grips, Tranz X Comfort Grip quick release skewers and quick release seat binder	Cannondale Ergo Lock-On grips, Tranz X Comfort Grip quick release skewers and quick release seat binder	Cannondale Ergo Lock-On grips, Tranz X Comfort Grip quick release skewers and quick release seat binder	Cannondale Ergo Lock-On grips, Tranz X Comfort Grip quick release skewers and quick release seat binder	

	<b>BAD BOY SOLO HEADSHOK</b>	<b>BAD BOY SOLO</b>	<b>BAD BOY</b>	<b>HOOLIGAN 3</b>	<b>HOOLIGAN 8</b>
<b>Code</b>	1BS1	1BS4	1BS5	OHL3	OHL8
<b>Frame</b>	Bad Boy Stealth, Optimized 6061 Alloy, HeadShok	Bad Boy Urban, Optimized 6061 alloy	Bad Boy Urban, Optimized 6061 alloy	Hooligan Delta V, Urban Compact, 6061 alloy, 20" wheel	Hooligan Delta V, Urban Compact, 6061 alloy, 20" wheel
<b>Fork</b>	HeadShok Solo DL50, lockout, OPI	Cannondale Solo, 1 1/8"	Cannondale Fatty Rigid, 1 1/8"	Cannondale Solo Rigid	Cannondale Fatty Rigid
<b>Rims</b>	Maddux SR300	Maddux SR300	Maddux SR300	Jalco X320 Disc, 20"	Jalco X320 Disc, 20"
<b>Hubs</b>	Cannondale Lefty front, Shimano M525 Deore rear	Cannondale Lefty front, Formula DC22 rear	Formula DC20 front, DC22 rear	Cannondale Lefty SL front, SRAM I Motion 3-speed rear	Formula DC20 front, DC22 rear
<b>Spokes</b>	Stainless XD Black	Stainless XD Black	Stainless XD Black	Stainless Steel XD Black, 15g	Stainless Steel XD Black, 15g
<b>Tires</b>	Schwalbe Kojak Race Guard, 700 x 28c	Schwalbe Kojak Race Guard, 700 x 28c	Schwalbe Kojak Race Guard, 700 x 28c	Schwalbe Kojak 1.35" race guard	Kenda Kwest 1.5"
<b>Pedals</b>	Cannondale Octopus Urban by Wellgo	Wellgo Platform, Resin, Cromo Axle	Wellgo Platform, Resin, Cromo Axle	Cannondale Octopus Urban, by Wellgo	Platform
<b>Crank</b>	Shimano M431, 48/36/26 Custom Bad Boy	Shimano M431, 48/36/26 Custom Bad Boy	Shimano M361, 48/38/28 Custom Bad Boy	FSA Vero, Dual Bash Guard, 42t	FSA Vero, Dual Bash Guard, 42t
<b>Bottom Bracket</b>	Tange Cartridge, JIS	Tange Cartridge, JIS	Tange Cartridge, JIS	Tange cartridge type	Tange cartridge type
<b>Chain</b>	KMC X9 Nano Black, 9-speed	KMC X9 Nano Black, 9-speed	KMC Z51 Nano Black, 8-speed	KMC Nano Black	KMC Z72
<b>Rear Cogs</b>	Sunrace CSM969, 11-32, black	Sunrace CSM969, 11-32, black	Sunrace CSM668, 11-32, black	N/A	Sunrace CSM969, 11-32, black
<b>Front Derailleur</b>	Shimano Deore M590	Shimano Deore M590	Shimano Altus M191	N/A	N/A
<b>Rear Derailleur</b>	Shimano SLX M662	Shimano Deore M592, Shadow	Shimano Alivio M410	N/A	Shimano 2300, 8-speed
<b>Shifters</b>	Shimano Deore M590, 9-speed	Shimano Deore M590, 9-speed	Shimano Altus M310, 8-speed	SRAM I Motion, 3-speed	Shimano Alivio M410
<b>Handlebar</b>	Cannondale Si Urban OPI Stem/Handlebar	Cannondale Urban, 5 mm Rise	Cannondale Urban, 6061, Flat	Cannondale C3, butted 6061 alloy, 25 mm rise	Cannondale C3, butted 6061 alloy, 25 mm rise
<b>Stem</b>	Cannondale Si Urban OPI Stem/Handlebar	Cannondale C4, 31.8	Cannondale C4, 31.8	Satori Race Fit Adjustable 1 1/8"	Satori Race Fit Adjustable 1 1/8"
<b>Headset</b>	Tange Custom HeadShok	Tange Custom Si 1 1/8"	Tange Custom Si 1 1/8"	Tange Integrated	Tange Integrated
<b>Brakes</b>	Shimano M505 Hydraulic Disc	Shimano M445 Hydraulic Disc	Tektro Novela Mechanical Disc	AVID BB5, Mechanical Disc	Tektro Novela Mechanical Disc
<b>Brake Levers</b>	Shimano M505	Shimano M445	Cannondale CBL 8.0	Cannondale 2 finger	Cannondale 2 finger
<b>Saddle</b>	Cannondale Bad Boy Urban	Cannondale Bad Boy Urban	Cannondale Bad Boy Urban	Cannondale Custom	Cannondale Custom
<b>Seatpost</b>	Cannondale C2, 2 bolt, alloy, 31.6, 350 mm	Cannondale C4 6061 alloy, 31.6, 350 mm	Cannondale C4 6061 alloy, 31.6, 350 mm	Cannondale Hooligan, 31.6 x 520 mm	Cannondale Hooligan, 31.6 x 520 mm
<b>Sizes</b>	S, M, L, X	S, M, L, X	S, M, L, X	One Size	One Size
<b>Color 1 (code)</b>	Jet Black (matte) (BBQ)	Jet Black (matte) (BBQ)	Jet Black (matte) (BBQ)	Jet Black (matte) (BBQ)	Magnesium White (gloss) (WHT)
<b>Color 2 (code)</b>				Magnesium White (gloss) (WHT)	
<b>Extras</b>	Cannondale Cityscape Urban Lock-On grips, Black Chrome	Cannondale Cityscape Urban Lock-On grips, Black Chrome	Cannondale Cityscape Urban Lock-On grips, Black Chrome	Cannondale Cityscape Urban Lock-On grips	Cannondale Cityscape Urban Lock-On grips

# FULL SUSPENSION MOUNTAIN GEOMETRY

## CLAYMORE

SPECIFICATIONS	SMALL	MEDIUM	LARGE	X-LARGE
A Seat Tube Length (cm/in)	39.5/15.6	43.0/16.9	47.0/18.5	51.0/20.1
B Top Tube Horizontal (cm/in)	54.9/21.6	58.2/22.9	61.1/24.1	64.3/25.3
C Top Tube Actual (cm/in)	52.9/20.8	55.6/21.9	58.2/22.9	61.3/24.1
D Head Tube Angle Hi BB	66.5°	67.0°	★	★
D Head Tube Angle Low BB	65.5°	66.0°	★	★
E Seat Tube Angle Effective	73.0°	72.6°	72.1°	71.8°
F Standover Hi BB (cm/in)	73.7/29.0	75.6/29.8	78.2/30.8	80.7/31.8
F Standover Low BB (cm/in)	72.6/28.6	74.5/29.3	77.1/30.3	79.6/31.3
G Head Tube Length (cm/in)	11.5/4.5	13.0/5.1	14.0/5.5	15.0/5.9
H Wheelbase (cm/in)	110.9/43.7	113.2/44.6	115.7/45.6	118.5/46.7
I Front Center (cm/in)	67.6/26.6	69.9/27.5	72.4/28.5	75.2/29.6
J Chain Stay Length (cm/in)	43.3/17.0	★	★	★
K Bottom Bracket Drop Hi BB (cm/in)	2.0/0.8	★	★	★
K Bottom Bracket Drop Low BB (cm/in)	0.8/0.3	★	★	★
L Bottom Bracket Height Hi BB (cm/in)	35.8/14.1	★	★	★
L Bottom Bracket Height Low BB (cm/in)	34.6/13.6	★	★	★
M Fork Rake (cm/in)	3.9/1.5	★	★	★
N Trail (cm/in)	10.5/4.1	10.2/4.0	10.2/4.0	10.2/4.0

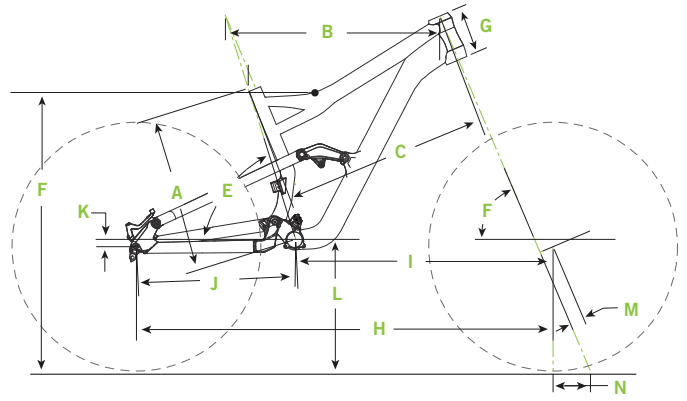

## JEKYLL

SPECIFICATIONS	SMALL	MEDIUM	LARGE	X-LARGE
A Seat Tube Length (cm/in)	43.2/17.0	45.7/18.0	48.3/19.0	50.8/20.0
B Top Tube Horizontal (cm/in)	55.6/21.9	58.8/23.1	61.4/24.2	64.2/25.3
C Top Tube Actual (cm/in)	53.4/21.0	56.4/22.2	59.1/23.3	61.8/24.3
D Head Tube Angle	67.7°	67.8°	67.9°	68.0°
E Seat Tube Angle Effective	73.6°	★	★	73.5°
F Standover (cm/in)	75.2/29.6	75.3/29.6	76.4/30.1	77.7/30.6
G Head Tube Length (cm/in)	13.4/5.3	H	H	16.0/6.3
H Wheelbase (cm/in)	110.0/43.3	113.1/44.5	115.5/45.5	118.4/46.6
I Front Center (cm/in)	67.2/26.5	70.3/27.7	72.7/28.6	75.6/29.8
J Chain Stay Length (cm/in)	42.8/16.9	★	★	★
K Bottom Bracket Drop (cm/in)	1.2/0.5	★	★	★
L Bottom Bracket Height (cm/in)	35.0/13.8	★	★	★
M Fork Rake (cm/in)	4.0/1.6	★	★	★
N Trail (cm/in)	9.5/3.8	9.5/3.8	9.4/3.7	9.3/3.7

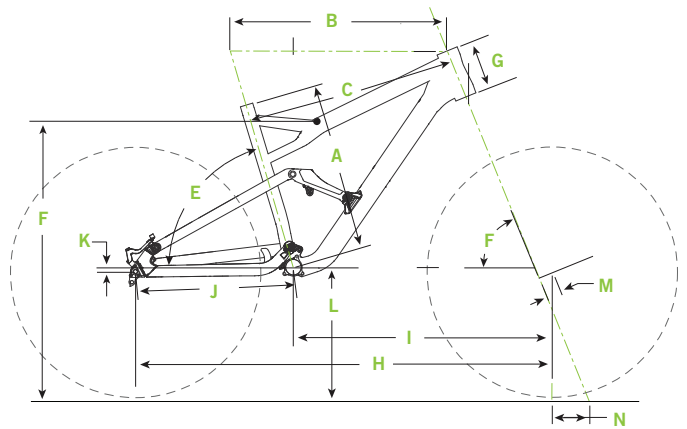

## RZ ONE TWENTY

SPECIFICATIONS	SMALL	MEDIUM	LARGE	X-LARGE
A Seat Tube Length (cm/in)	43.2/17.0	45.7/18.0	48.3/19.0	50.9/20.0
B Top Tube Horizontal (cm/in)	56.0/22.0	58.7/23.1	61.3/24.1	64.1/25.2
C Top Tube Actual (cm/in)	53.5/21.1	56.2/22.1	59.1/23.3	61.9/24.4
D Head Tube Angle	69.0°	★	★	★
E Seat Tube Angle Effective	73.5°	★	★	★
F Standover (cm/in)	73.1/28.8	76.0/29.9	76.1/30.0	76.0/29.9
G Head Tube Length (cm/in)	13.4/5.3	★	★	16.0/6.3
H Wheelbase (cm/in)	107.6/42.4	110.3/43.4	113.0/44.5	116.0/45.7
I Front Center (cm/in)	65.2/25.7	67.8/26.7	70.5/27.8	73.5/28.9
J Chain Stay Length (cm/in)	42.5/16.7	★	★	★
K Bottom Bracket Drop (cm/in)	0.0/0.0	★	★	★
L Bottom Bracket Height (cm/in)	33.0/13.0	★	★	★
M Fork Rake (cm/in)	4.5/1.8	★	★	★
N Trail (cm/in)	7.8/3.1	★	★	★

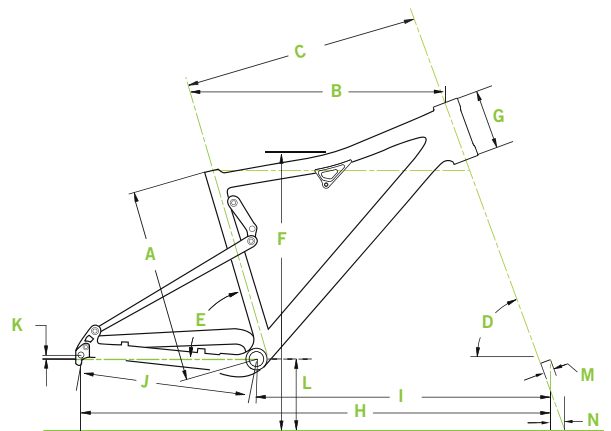

## SCALPEL

SPECIFICATIONS	SMALL	MEDIUM	LARGE	X-LARGE
A Seat Tube Length (cm/in)	40.5/15.9	43.5/17.1	48.2/19.0	53.2/20.9
B Top Tube Horizontal (cm/in)	55.5/21.9	58.5/23.0	61.5/24.2	64.0/25.2
C Top Tube Actual (cm/in)	53.4/21.0	56.2/22.1	59.5/23.4	62.7/24.7
D Head Tube Angle	69.3	69.6	69.8	70.0
E Seat Tube Angle Effective	74.0	★	★	★
F Standover (cm/in)	75.9/29.9	75.7/29.8	75.4/29.7	75.4/29.7
G Head Tube Length (cm/in)	13.4/5.3	★	★	★
H Wheelbase (cm/in)	107.4/42.3	110.0/43.3	112.8/44.4	115.1/45.3
I Front Center (cm/in)	65.0/25.6	67.7/26.6	70.4/27.7	72.7/28.6
J Chain Stay Length (cm/in)	42.4/16.7	★	★	★
K Bottom Bracket Drop (cm/in)	1.2/0.5	★	★	★
L Bottom Bracket Height (cm/in)	31.8/12.5	★	★	★
M Fork Rake (cm/in)	4.5/1.8	★	★	★
N Trail (cm/in)	7.7/3.0	7.5/2.9	7.4/2.9	7.2/2.8

★ Indicates same as previous

# HARDTAIL MOUNTAIN GEOMETRY

## FLASH CARBON FLASH

SPECIFICATIONS	SMALL	MEDIUM	LARGE	X-LARGE
A Seat Tube Length (cm/in)	38.0/15	43.3/17	47.5/18.7	52.5/20.7
B Top Tube Horizontal (cm/in)	55.0/21.7	58.5/23	61.4/24.2	62.9/24.8
C Top Tube Actual (cm/in)	53.8/21.2	56.3/22.2	58.9/23.2	60.8/23.9
D Head Tube Angle	70.0°	★	★	★
E Seat Tube Angle Effective	73.5°	73.5°	73.0°	72.5°
F Standover (cm/in)	74.4/29.3	77.0/30.3	78.9/31.1	81.3/32
G Head Tube Length (cm/in)	13.4/5.3	★	★	★
H Wheelbase (cm/in)	104.9/41.3	108.4/42.7	110.8/43.6	111.7/44
I Front Center (cm/in)	62.7/24.7	66.2/26.1	68.6/27	69.5/27.4
J Chain Stay Length (cm/in)	42.4/16.7	★	★	★
K Bottom Bracket Drop (cm/in)	3.0/1.2	★	★	★
L Bottom Bracket Height (cm/in)	29.5/11.6	★	★	★
M Fork Rake (cm/in)	4.5/1.8	★	★	★
N Trail (cm/in)	7.0/2.8	★	★	★

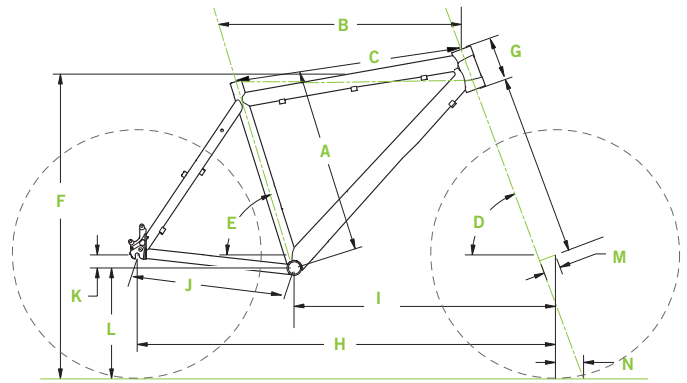

## TRAIL SL

SPECIFICATIONS	SMALL	MEDIUM	LARGE	X-LARGE
A Seat Tube Length (cm/in)	38.0/15	43.3/17	47.5/18.7	52.5/20.7
B Top Tube Horizontal (cm/in)	55.0/21.7	58.4/23	61.4/24.2	62.9/24.8
C Top Tube Actual (cm/in)	53.9/21.2	56.3/22.2	58.9/23.2	60.4/23.8
D Head Tube Angle	70.0°	★	★	★
E Seat Tube Angle Effective	73.5°	73.5°	73.0°	72.5°
F Standover (cm/in)	74.3/29.3	76.8/30.2	78.8/31	82.6/32.5
G Head Tube Length (cm/in)	11.4/4.5	★	★	14.4/5.7
H Wheelbase (cm/in)	104.7/41.2	108.2/42.6	110.6/43.5	111.7/44
I Front Center (cm/in)	62.6/24.6	66.0/26	68.4/26.9	69.5/27.4
J Chain Stay Length (cm/in)	42.4/16.7	★	★	★
K Bottom Bracket Drop (cm/in)	3.5/1.4	★	★	★
L Bottom Bracket Height (cm/in)	29.0/11.4	★	★	★
M Fork Rake (cm/in)	4.5/1.8	★	★	★
N Trail (cm/in)	7.0/2.8	★	★	★

## TRAIL

SPECIFICATIONS	SMALL	MEDIUM	LARGE	X-LARGE	X-LARGE
A Seat Tube Length (cm/in)	38.0/15	43.3/17	47.5/18.7	52.5/20.7	57.0/22.4
B Top Tube Horizontal (cm/in)	55.1/21.7	58.4/23	61.4/24.2	63.0/24.8	63.6/25
C Top Tube Actual (cm/in)	53.8/21.2	56.7/22.3	58.9/23.2	60.5/23.8	61.3/24.1
D Head Tube Angle	70.0°	★	★	★	★
E Seat Tube Angle Effective	73.5°	73.5°	73.0°	72.5°	72.5°
F Standover (cm/in)	73.8/29.1	76.9/30.3	79.2/31.2	82.2/32.4	85.7/33.7
G Head Tube Length (cm/in)	10.5/4.1	11.5/4.5	12.2/4.8	13.5/5.3	16.5/6.5
H Wheelbase (cm/in)	104.7/41.2	108.2/42.6	110.6/43.5	111.7/44	112.4/44.3
I Front Center (cm/in)	62.6/24.6	66.0/26	68.5/27	69.5/27.4	70.3/27.7
J Chain Stay Length (cm/in)	42.4/16.7	★	★	★	★
K Bottom Bracket Drop (cm/in)	3.5/1.4	★	★	★	★
L Bottom Bracket Height (cm/in)	29.0/11.4	★	★	★	★
M Fork Rake (cm/in)	4.5/1.8	★	★	★	★
N Trail (cm/in)	7.0/2.8	★	★	★	★

## FLASH CARBON 29'ER FLASH 29'ER

SPECIFICATIONS	MEDIUM	LARGE	X-LARGE
A Seat Tube Length (cm/in)	43.3/17	47.5/18.7	52.5/20.7
B Top Tube Horizontal (cm/in)	59.3/23.3	62.2/24.5	64.1/25.2
C Top Tube Actual (cm/in)	57.8/22.8	59.7/23.5	61.2/24.1
D Head Tube Angle	71.0°	71.0°	71.5°
E Seat Tube Angle Effective	73.5°	73.0°	72.5°
F Standover (cm/in)	80.9/31.9	82.9/32.6	85.3/33.6
G Head Tube Length (cm/in)	13.4/5.3	13.4/5.3	11.4/4.5
H Wheelbase (cm/in)	108.8/42.8	111.1/43.7	111.8/44
I Front Center (cm/in)	65.2/25.7	67.5/26.6	68.2/26.9
J Chain Stay Length (cm/in)	44.4/17.5	★	★
K Bottom Bracket Drop (cm/in)	6.5/2.6	★	★
L Bottom Bracket Height (cm/in)	30.5/12	★	★
M Fork Rake (cm/in)	4.5/1.8	★	★
N Trail (cm/in)	8.0/3.1	8.0/3.1	7.6/3

## TRAIL SL 29'ER

SPECIFICATIONS	MEDIUM	LARGE	X-LARGE
A Seat Tube Length (cm/in)	43.3/17	47.5/18.7	52.5/20.7
B Top Tube Horizontal (cm/in)	61.3/24.1	63.0/24.8	63.6/25
C Top Tube Actual (cm/in)	58.8/23.1	60.4/23.8	61.3/24.1
D Head Tube Angle	70.0°	★	★
E Seat Tube Angle Effective	73.5°	73.0°	72.5°
F Standover (cm/in)	82.0/32.3	84.4/33.2	85.7/33.7
G Head Tube Length (cm/in)	★	★	★
H Wheelbase (cm/in)	112.5/44.3	113.5/44.7	114.4/45.0
I Front Center (cm/in)	67.7/26.7	68.8/27.1	69.5/27.4
J Chain Stay Length (cm/in)	★	★	★
K Bottom Bracket Drop (cm/in)	★	★	★
L Bottom Bracket Height (cm/in)	★	★	★
M Fork Rake (cm/in)	★	★	★
N Trail (cm/in)	★	★	★

★ Indicates same as previous



# ROAD GEOMETRY

## SUPERSIX / CAAD10

SPECIFICATIONS	48	50	52	54	56	58	60	63
A Horizontal Top Tube Length (cm)	51.5	52.5	53.5	54.5	56.0	57.5	59.0	60.0
B Measured Size (cm)*	46	48	50	52	54	56	58	61
C Seat Tube Angle (degrees)	74.5	74.5	74	73.5	73.5	73	72.5	72
D Head Tube Angle (degrees)	72	72.5	73	73	73	73.5	73.5	73.5
E Chain Stay Length (cm)	40.5	★	★	★	★	★	40.8	40.8
F Fork Rake (cm)	4.5	★	★	★	★	★	★	★
G Bottom Bracket Height (cm)	26.5	26.5	26.5	26.8	26.8	27.0	27.0	27.0
H Wheelbase (cm)	95.9	96.6	96.8	97.5	99.2	99.6	100.1	101.3
I Trail (cm)	6.2	5.9	5.6	5.6	5.6	5.3	5.3	5.3
J Standover at Top Tube Midpoint (cm)	74	75.3	76.5	78.5	80.1	82.2	83.8	86.6
K Bottom Bracket Drop (cm)	7.2	7.2	7.2	6.9	6.9	6.7	6.7	6.7
L Front Center Distance (cm)	56.5	57.2	57.4	58.0	59.7	60.1	61.0	61.4
M Head Tube Length (cm)	11	11.5	12.0	14.0	15.5	17.5	19.0	22.0
N Stack (cm)**	51.7	52.3	52.9	54.6	56.0	57.9	59.3	62.2
O Reach (cm)	36.8	37.8	38.2	38.3	39.4	39.9	40.4	39.9

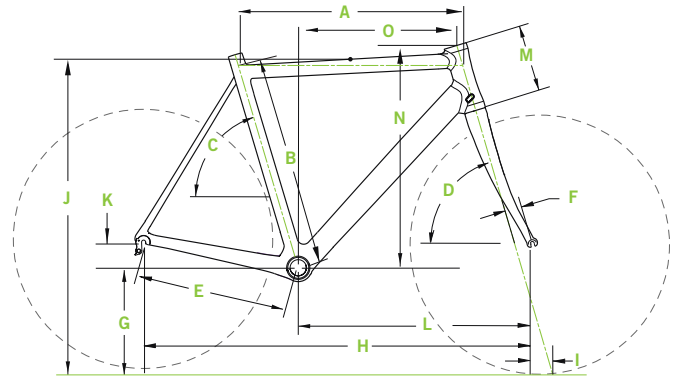

\* The measured size is from the center of the bottom bracket to the top of the top tube, measured along the seat tube axis.  
All sizes have a slightly sloping top tube.  
\*\* Stack is measured vertically from the center of the BB to the top of the head tube, reach is measured horizontally from the center of the BB to the top of the head tube.

## CAAD8

## SLICE

## SYNAPSE CARBON

SPECIFICATIONS	48	51	54	56	58	61	51	54	56	58	60	48	51	54	56	58	61
A Horizontal Top Tube Length (cm)	51	53	54.5	56	57.5	59.5	50.5	53.5	55	56.5	58	51	52.5	54	56	58	60
B Measured Size (cm)*	45	49	52	54	57	59	50	51.5	53.5	55.5	57.5	42	45	48	51	53	56
C Seat Tube Angle (degrees)	75	74.5	73.5	73.5	73	72.5	*variable	variable	variable	variable	variable	74.5	74	74	73.5	73	72.5
D Head Tube Angle (degrees)	72	72.5	73	73	73.5	73.5	71.5	71.5	72	72	72	71	72	72	72.5	73	73
E Chain Stay Length (cm)	40.8	★	★	★	★	★	40	★	★	★	★	41	★	★	★	★	★
F Fork Rake (cm)	5	5	4.5	★	★	★	4.5	★	★	★	★	5.0	5.0	4.5	★	★	★
G Bottom Bracket Height (cm)	26.5	26.5	26.8	26.8	270	270	26.5	26.5	26.5	26.5	26.5	26.5	26.5	26.8	26.8	27.0	27.0
H Wheelbase (cm)	96.6	97.9	97.8	99.3	99.9	101.3	95.4	98.5	99.7	101.3	102.6	97.0	97.5	98.7	99.9	101.1	102.6
I Trail (cm)	5.7	5.4	5.6	5.6	5.3	5.3	6.5	6.5	6.2	6.2	6.2	6.3	6.2	6.2	5.9	5.6	5.6
J Standover at Top Tube Midpoint (cm)	74.6	76.8	79.2	80.8	82.9	85.7	74.9	76.4	78.3	80.2	82.2	72.1	74.4	77.1	79.1	81.1	83.4
K Bottom Bracket Drop (cm)	7.2	7.2	6.9	6.9	6.7	6.7	7.2	★	★	★	★	★	7.2	6.9	6.9	6.7	6.7
L Front Center Distance (cm)	56.9	58.2	58.0	59.5	60.0	61.5	56.5	59.6	60.7	62.3	63.9	57.1	57.6	58.7	59.9	61.0	62.5
M Head Tube Length (cm)	12.5	14.0	15.5	17.0	19.0	22.0	9	10.5	12.5	14.5	17	13	14.5	16.5	18	20	22
N Stack (cm)**	52.9	54.5	56.0	57.4	59.3	62.2	**49.4	50.9	52.9	54.8	57.2	53.0	54.8	56.6	58.2	60.1	62.0
O Reach (cm)	36.3	37.6	37.9	38.9	39.4	40.0	**37.1	39.8	40.7	41.7	42.5	35.5	36.3	37.4	38.6	39.6	40.5

\* The Slice seat post has two positions for mounting the saddle. A full range of angles from 73 to 78 degrees is achievable depending on the rider's preference and/or the event.  
If you ride a 56 road frame, you should choose a size 56 Slice frame.  
All sizes have 700c wheels.

## SYNAPSE ALLOY

## SUPERX

## CAADX

SPECIFICATIONS	48	51	54	56	58	61	44	48	52	54	56	58	44	48	51	54	56	58	61
A Horizontal Top Tube Length (cm)	51	52.5	54	56	58	60	51	52	54	55	57	59	51.5	52.5	53.5	54.5	56.0	57.5	59.0
B Measured Size (cm)*	44	47	50	53	55	58	44	48	52	54	56	58	44	47	50	53	55	57	60
C Seat Tube Angle (degrees)	74.5	74	74	73.5	73	72.5	75	74	73.5	73.5	73	73	75	74.5	74	73.5	73	73	72.5
D Head Tube Angle (degrees)	70.5	72	72	72.5	73	73	69	69.5	71.5	72	72.5	72.5	69.5	70.5	71	72	72.5	72.5	72.5
E Chain Stay Length (cm)	41.5	★	★	★	★	★	43	★	★	★	★	★	43.2	43.2	43.2	43.2	43.2	43.2	43.2
F Fork Rake (cm)	5.0	★	★	★	★	★	4.5	★	★	★	★	★	5	★	★	★	★	★	★
G Bottom Bracket Height (cm)	26.5	26.5	26.8	26.8	27.0	27.0	28.1	★	★	★	★	★	28.3	★	★	★	★	★	★
H Wheelbase (cm)	97.9	98.0	99.8	100.9	102.1	103.6	101.7	101.4	101.1	101.7	102.6	104.7	101.8	101.3	101.6	102.3	103.3	105.4	105.8
I Trail (cm)	6.6	5.7	5.7	5.4	5.1	5.1	8.5	8.4	7.0	6.7	6.4	6.4	7.7	7.0	6.7	6.0	5.7	5.7	5.7
J Standover at Top Tube Midpoint (cm)	73.2	75.6	78.1	80.2	82.2	84.5	74.9	77.0	80.4	82.2	83.6	85.5	75.5	77.7	79.8	81.9	83.0	85.0	87.3
K Bottom Bracket Drop (cm)	7.2	7.2	6.9	6.9	6.7	6.7	6.7	★	★	★	★	★	6.7	★	★	★	★	★	★
L Front Center Distance (cm)	57.5	57.6	59.3	60.4	61.5	63.0	59.6	59.3	59.0	59.6	60.5	62.6	59.5	59.0	59.3	60.0	61.0	63.0	63.5
M Head Tube Length (cm)	13	14.5	16.5	18	20	22	10	11	13.5	15	16	18	12	13.0	14.5	15.5	16.0	18.0	20.0
N Stack (cm)**	52.9	54.8	56.4	58.0	59.9	61.9	51.8	52.9	56.0	57.6	58.8	60.7	53.8	55.1	56.7	58.0	58.7	60.6	62.5
O Reach (cm)	35.5	36.4	37.5	38.7	39.7	40.6	37.1	36.8	37.4	37.9	39.0	40.5	36.2	36.2	36.4	37.7	39.0	40.4	40.3

If you ride a size 56 cm Cannondale road bike, you should choose a 54 cm Cyclocross frame. This will give you a similar top tube length but more standover height.

All sizes have a slightly sloping top tube.

★ Indicates same as previous

# RECREATION / URBAN GEOMETRY

## QUICK CARBON

SPECIFICATIONS		SMALL	MEDIUM	LARGE	X-LARGE	JUMBO
A*	Measured Size (cm/in)*	38.5/15.2	41/16.1	46/18.1	51/20.1	57/22.4
B	Seat Tube Angle	75	76	74.5	73	72.5
C	Head Tube Angle	71	71	71.5	72	72.5
D	Horizontal Top Tube Length (cm)	53.5	53.5	56	58.5	62
E	Chain Stay Length (cm)	43	43	★	★	★
F	Fork Rake (cm)	5.0	5.0	★	★	★
G	Bottom Bracket Height (cm)	27.4	27.4	27.4	27.4	27.4
H	Wheelbase (cm)	101.4	102.3	103.9	104.8	107.5
I	Trail (cm)	6.6	6.5	6.2	5.9	5.6
J	Standover Height (cm)	73.8	75.0	78.7	82.8	87.0
K	Bottom Bracket Drop (cm)	7.0	★	★	★	★
L	Front Center (cm)	59.5	60.4	61.9	62.8	65.4
M	Head Tube Length (cm)	14	13	16	19	22

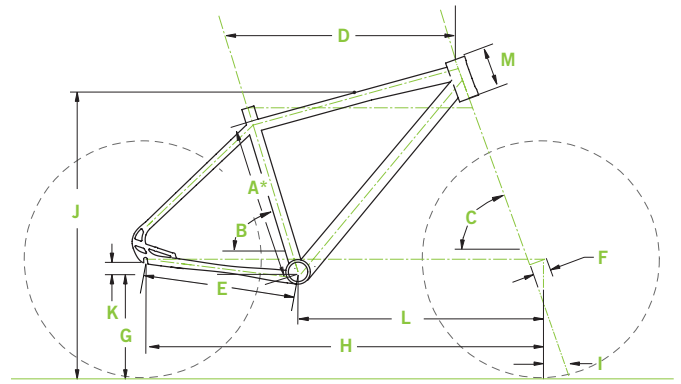

\*Measured size is from the center of the bottom bracket to the top of the top tube, measured along the seat tube axis.

## QUICK SL QUICK

SPECIFICATIONS		X-SMALL	SMALL	MEDIUM	LARGE	X-LARGE	JUMBO
Wheel Size		26"	700c	700c	700c	700c	700c
A*	Measured Size (cm/in)*	32.0/12.6	38.5/15.2	41.0/16.1	46.0/18.1	51.0/20.1	57.0/22.4
B	Seat Tube Angle	76	75	75	74.5	73	72.5
C	Head Tube Angle	70.5	70.5	70.5	71	71.5	72
D	Horizontal Top Tube Length (cm)	50.5	53.5	54.5	56	58.5	62
E	Chain Stay Length (cm)	43.5	★	★	★	★	★
F	Fork Rake (cm)	5	★	★	★	★	★
G	Bottom Bracket Height (cm)	27.4	★	★	★	★	★
H	Wheelbase (cm)	100.5	102.4	103.7	104.7	105.7	108.4
I	Trail (cm)	6.2	6.9	6.9	6.6	6.2	5.9
J	Standover Height (cm)	68.9	74.5	75.9	79.3	83.1	87.3
K	Bottom Bracket Drop (cm)	5.1	7.0	★	★	★	★
L	Front Center (cm)	57.5	60.0	61.1	62.2	63.2	65.9
M	Head Tube Length (cm)	14	14	15	17	20	23

## QUICK CX HEADSHOK

SMALL	MEDIUM	LARGE	X-LARGE	JUMBO
40.2/15.8	44.2/17.4	48.2/19.5	52.2/20.5	56.2/22.1
74	73.5	73	73	72.5
69	69	70	70.5	71.5
54	55	56.5	58	60.5
45	★	★	★	★
4.5	★	★	★	★
28.0	★	★	★	★
104.9	105.8	106.2	107.5	108.6
8.5	8.5	7.8	7.5	6.9
75.3	77.9	80.0	82.4	85.0
6.7	★	★	★	★
60.7	61.6	62.1	63.3	64.5
11.4	★	★	★	★

## QUICK CX

SMALL	MEDIUM	LARGE	X-LARGE	JUMBO
40.2/15.8	44.2/17.4	48.2/19.5	52.2/20.5	56.2/22.1
74	73.5	73	73	72.5
69	69	70	70.5	71.5
54	55	56.5	58	60.5
45	★	★	★	★
4.5	★	★	★	★
28.0	★	★	★	★
104.9	105.8	106.2	107.5	108.6
8.5	8.5	7.8	7.5	6.9
75.3	77.9	80.0	82.4	85.0
6.7	★	★	★	★
60.7	61.6	62.1	63.3	64.5
14	15	16	17	18

## ADVENTURE

SPECIFICATIONS		SMALL	MEDIUM	LARGE	X-LARGE	JUMBO
A*	Seat Tube Length Overall (cm/in)	35.6/14.0	40.6/16.0	45.7/18.0	53.3/21.0	61.0/24.0
B	Seat Tube Angle	70	★	★	★	★
C	Head Tube Angle	69	★	★	★	★
D	Horizontal Top Tube Length (cm)	56.5	57.2	58	59	60
E	Chain Stay Length (cm)	46.5	★	★	★	★
F	Fork Rake (cm)	4.5	★	★	★	★
G	Bottom Bracket Height (cm)	28.0	★	★	★	★
H	Wheelbase (cm)	105.4	106.2	107.1	108.2	109.4
I	Trail (cm)	8.5	★	★	★	★
J	Standover Height (cm)	70	73.2	77.2	82.2	86.3
K	Bottom Bracket Drop (cm)	6.8	★	★	★	★
L	Front Center (cm)	59.8	60.6	61.4	62.3	63.7
M	Head Tube Length (cm)	13.6	13.6	15.6	17.1	17.1

## ADVENTURE 26"

SMALL	MEDIUM	LARGE	X-LARGE	JUMBO
35.6/14.0	40.6/16.0	45.7/18.0	53.3/21.0	61.0/24.0
70	★	★	★	★
69	★	★	★	★
55	55.7	56.5	58	59.5
45.7	★	★	★	★
4.5	★	★	★	★
30.3	★	★	★	★
104.2	105.0	105.9	107.6	109.2
8.5	★	★	★	★
70.8	73.9	77.8	82.7	86.7
4.5	★	★	★	★
59.8	60.6	61.4	62.3	63.7
13.6	13.6	15.6	17.1	17.1

★ Indicates same as previous

# RECREATION / URBAN GEOMETRY

		<b>TANDEM</b>			
<b>SPECIFICATIONS</b>		<b>M/S</b>	<b>L/S</b>	<b>X/S</b>	<b>J/M</b>
<b>A</b>	Front Seat Tube Angle (degrees)	73	★	★	★
<b>B</b>	Rear Seat Tube Angle (degrees)	73	★	★	★
<b>C</b>	Head Tube Angle (degrees)	73	★	★	★
<b>D</b>	Horizontal Front Top Tube Length (in/cm)	21.5/54.5	22.0/56.0	22.6/57.5	23.6/60.0
<b>E</b>	Horizontal Rear Top Tube Length (in/cm)	28.6/72.6	★	★	29.1/73.9
<b>F</b>	Front Seat Tube Overall Length (in/cm)	19.0/48.3	20.0/50.8	22.0/55.9	23.0/58.4
<b>G</b>	Rear Seat Tube Overall Length (in/cm)	17.0/43.2	★	★	19.0/48.3
<b>H</b>	Rear Seat Tube Measured Length (in/cm)	15.6/39.7	15.6/39.7	17.0/43.2	19.0/48.3
<b>I</b>	Head Tube Length (in/cm)	5.9/15.0	6.5/16.5	7.1/18.0	7.9/20.0
<b>J</b>	Chain Stay Length (in/cm)	17.4/44.2	★	★	★
<b>K</b>	Fork Rake (in/cm)	2.1/5.3	★	★	★
<b>L</b>	Front Bottom Bracket Height (in/cm)	10.8/27.4	★	★	★
<b>M</b>	Rear Bottom Bracket Height (in/cm)	10.5/26.7	★	★	★
<b>N</b>	Wheelbase (in/cm)	68.4/173.6	69.0/175.1	69.5/176.6	71.0/180.4
<b>O</b>	Trail (in/cm)	2.0/5.1	★	★	★
<b>P</b>	Front Standover at Top Tube midpoint (in/cm)	28.2/71.7	30.6/77.7	31.6/80.3	32.5/82.6
<b>Q</b>	Rear Standover at Top Tube midpoint (in/cm)	25.4/64.6	26.3/66.8	27.6/70.2	29.5/74.0
<b>R</b>	Front Bottom Bracket Drop (in/cm)	2.9/7.4	★	★	★
<b>S</b>	Rear Bottom Bracket Drop (in/cm)	3.2/8.1	★	★	★
<b>T</b>	Front Center Distance (in/cm)	22.9/58.3	23.5/59.7	24.1/61.2	25.1/63.7

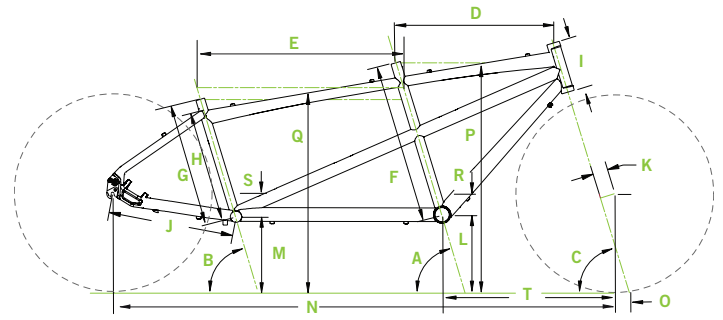

		<b>HOOLIGAN</b>
<b>SPECIFICATIONS</b>		<b>ONE SIZE</b>
<b>A</b>	Seat Tube Length (cm/in)	35.0/14.6
<b>B</b>	Top Tube Horizontal (cm/in)	58.0
<b>C</b>	Top Tube Actual (cm/in)	54.7/21.5
<b>D</b>	Head Tube Angle	70
<b>E</b>	Seat Tube Angle Effective	73
<b>F</b>	Standover (cm/in)	60
<b>G</b>	Head Tube Length (cm/in)	17.1
<b>H</b>	Wheelbase (cm/in)	106
<b>I</b>	Front Center (cm/in)	66.2
<b>J</b>	Chain Stay Length (cm/in)	40
<b>K</b>	Bottom Bracket Drop (cm/in)	3.6
<b>L</b>	Bottom Bracket Height (cm/in)	30.5
<b>M</b>	Fork Rake (cm/in)	4.5
<b>N</b>	Trail (cm/in)	2.6

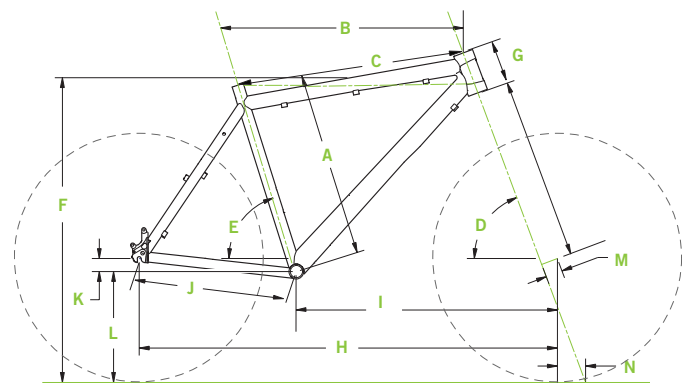

		<b>BAD BOY HEADSHOK</b>				<b>BAD BOY</b>			
<b>SPECIFICATIONS</b>		<b>SMALL</b>	<b>MEDIUM</b>	<b>LARGE</b>	<b>X-LARGE</b>	<b>SMALL</b>	<b>MEDIUM</b>	<b>LARGE</b>	<b>X-LARGE</b>
<b>A</b>	Seat Tube Length (cm/in)	39/15.4	46/18.1	51/20.1	56/22.0	39/15.4	46/18.1	51/20.1	56/22.0
<b>B</b>	Top Tube Horizontal (cm/in)	55	57.5	60	62	55	57.5	60	62
<b>C</b>	Top Tube Actual (cm/in)	52.1/20.5	54.7/21.5	57.3/22.6	59.7/23.5	52.1/20.5	54.7/21.5	57.3/22.6	59.7/23.5
<b>D</b>	Head Tube Angle	70	71	★	★	70	71	★	★
<b>E</b>	Seat Tube Angle Effective	74.5	73.5	73	72.5	74.5	73.5	73	72.5
<b>F</b>	Standover (cm/in)	77	80.4	82.6	84.7	73.9	78.2	81.4	84.5
<b>G</b>	Head Tube Length (cm/in)	11.4	★	★	★	13	15	17	19
<b>H</b>	Wheelbase (cm/in)	104.4	105.8	108.1	109.8	104.4	105.8	108.1	109.8
<b>I</b>	Front Center (cm/in)	61.4	62.8	65.1	66.8	61.4	62.8	65.1	66.8
<b>J</b>	Chain Stay Length (cm/in)	43.5	★	★	★	43.5	★	★	★
<b>K</b>	Bottom Bracket Drop (cm/in)	5.1	★	★	★	5.1	★	★	★
<b>L</b>	Bottom Bracket Height (cm/in)	29.5	★	★	★	73.9	78.2	81.4	84.5
<b>M</b>	Fork Rake (cm/in)	4.5	★	★	★	4.5	★	★	★
<b>N</b>	Trail (cm/in)	7.8	7.2	★	★	7.8	7.2	★	★

★ Indicates same as previous

# 2011 WOMEN'S BICYCLES



**cannondale**

# 2011

## TIME TO RIDE

*Our promise to you: no frou frou and no girly gimmicks, just real products with real benefits for real performance, designed by other women cyclists to make cycling more fun.*

*For almost 30 years, we've been listening to you, your thoughts, your needs, your "if only they could make it..." and "all I want is..." requests and turning them into products that make a difference, that make riding more enjoyable and more comfortable and keep you on your bikes.*

*We've taken the time to find what works best for you. We constantly listen to our focus groups, whether formal sit downs or the lunch-time two-wheeled variety. We test hundreds of products and components. We work closely with our engineers. We strive for better fit because the result for you is better comfort and performance.*

*We are a team of experienced female cyclists who understand the challenges of giving women the cycling products they not only need, but truly want. Whether cruising out of the driveway, rolling up to the line at the local crit or launching your first air in the bike park, you know we've got you covered.*

*Our 40th anniversary brings even more tasty goodies to our Women's line. All designed for you. All packaged with kickass new graphics to keep you inspired and turning heads wherever the road or trail leads you.*

*Each of our bikes is uniquely Cannondale: high performance, cutting edge, best-in-class and never watered down; designed to motivate you and inspire you because, above all, we believe that cycling should be empowering, exhilarating and fun.*



**OVERMOUNTAIN**

SCARLET 4-5

**FULL SUSPENSION**

LEXI 6-8

**HARDTAIL**

FLASH 9

TRAIL SL / TRAIL 10-11

**ELITE ROAD**

SUPERSIX 12-15

CAAD10 16-17

**TRIATHLON / TIME TRIAL**

SLICE 18-19

**PERFORMANCE ROAD**

SYNAPSE CARBON 20-23

SYNAPSE ALLOY 24-25

**WOMEN'S RECREATION**

QUICK 26-29

ADVENTURE 30-31

# WOMEN'S



GET  
DIRTY!



# SCARLET

**BUILT FOR WOMEN WHO RIP.**

**WORK LESS ON THE CLIMBS.  
SHRED HARDER ON THE DESCENTS.  
SMILE MORE EVERYWHERE.  
WITH SCARLET, A SPLIT PERSONALITY  
IS A VERY GOOD THING.**

## SCARLET SUSPENSION SYSTEM

The radical **DYAD RT2** dual shock and **Scarlet's** shock linkage were designed for each other, providing incredible smoothness, traction and efficiency in the **Elevate** mode, and a fluid, bottomless feel in **Flow** mode. Climb faster, descend better.

## GET CONNECTED

Control equals confidence. Confidence equals speed. Scarlet's 5-part **ECS-TC** (Enhanced Center-Stiffness, Torsion Control) system eliminates unwanted flex and play in the links and pivots, unifying the frame and delivering unmatched responsiveness and control.

## WOMEN'S GEOMETRY

We strongly believe that your bike shouldn't limit your riding, so we designed **Scarlet** with details like a lower standover height and a shorter reach that matches a women's physique. Rock it with confidence.



## SCARLET 1

Jet Black (matte) (BBQ).

<b>FRAME</b>	Scarlet 150/90 mm, SmartFormed Alloy, ISCG03, BB30, 1.5 Si headtube
<b>SUSPENSION (R/F)</b>	Fox Dyad RT2/Fox 32 Talas RL, 150 mm, 15QR
<b>WHEELS</b>	DT Swiss 445, 32 hole

<b>SHIFTERS</b>	Shimano XT
<b>REAR DERAILLEUR</b>	Shimano XT, 10- speed
<b>CRANK</b>	FSA Afterburner BB30, 44/32/22

<b>BRAKES</b>	Avid Elixir CR, 185/185 mm
<b>TIRES</b>	Schwalbe Nobby Nic PaceStar, 2.4", folding
<b>SIZES</b>	P, S, M



## SCARLET 2

Magnesium White (gloss) (WHT).

<b>FRAME</b>	Scarlet 150/90 mm, SmartFormed Alloy, ISCG03, BB30, 1.5 Si headtube	<b>SHIFTERS</b>	SRAM X7	<b>BRAKES</b>	Hayes Stroker Ryde Comp, 185/160 mm
<b>SUSPENSION (R/F)</b>	Fox Dyad RT2/RockShox Revelation, 150 mm, Dual Air, All Travel, 15 mm thru	<b>REAR DERAILLEUR</b>	SRAM X7, 9-speed	<b>TIRES</b>	Kenda Nevegal, 2.35", folding
<b>WHEELS</b>	SunRingle SR25, 32 hole	<b>CRANK</b>	TruVativ FireX 3.1, 44/24/22	<b>SIZES</b>	P, S, M

# LEXI



## LEXI 1

Magnesium White (gloss) (WHT).

<b>FRAME</b>	Lexi, 120 mm, SmartFormed Alloy, BB30, 1.5 Si headtube	<b>SHIFTERS</b>	SRAM X7	<b>BRAKES</b>	Hayes Stroker Trail Carbon SL, 160/160 mm
<b>SUSPENSION (R/F)</b>	RockShox Monarch RT3/Lefty Ultra PBR, 120 mm	<b>REAR DERAILLEUR</b>	SRAM X9, 10-speed	<b>TIRES</b>	Kenda Slant 6, 2.1", folding
<b>WHEELS</b>	DT Swiss 1.7, 24/28 hole	<b>CRANK</b>	FSA Comet 386 BB30, 39/27	<b>SIZES</b>	P, S, M

# LOVES TO GET DIRTY.

*THE ULTIMATE WOMEN'S BIKE FOR MARATHON RACING AND ALL-DAY RIDING. GO AHEAD, GET DIRTY.*



## **1** SIZE-SPECIFIC SHOCK LINK

Instead of just lowering the shock mount, we created an entirely different linkage so that Lexi's smaller frames maintain the refined leverage ratios and shock performance of our larger frames.

## **2** OPI BACKBONE, ONE-PIECE INTEGRATION

Lexi's seat tube, BB shell and swingarm pivot are 3D forged as one piece, eliminating excess material and providing uniform grain alignment throughout for extreme strength in this crucial area.

## **3** MUSCLE LESS, RIDE MORE

Lexi's front end features our System Integration approach which designs parts in harmony to enhance weight saving and performance. The benefit to you is a light, nimble front end that you won't have to muscle around.



## LEXI 2

Soldier of Fortune (matte) (GRN).

<b>FRAME</b>	Lexi, 120 mm, SmartFormed Alloy, BB30, 1.5 Si headtube	<b>SHIFTERS</b>	Shimano SLX	<b>BRAKES</b>	Avid Elixir 3, 185/160 mm
<b>SUSPENSION (R/F)</b>	RockShox Monarch RT/RockShox Recon Silver TK, 120 mm, 20 mm thru	<b>REAR DERAILLEUR</b>	Shimano XT, 10-speed	<b>TIRES</b>	Kenda Slant 6, 2.1", folding
<b>WHEELS</b>	Maddux DC 3.0, double wall w/eyelet, 28 hole	<b>CRANK</b>	Shimano M542, 44/32/22	<b>SIZES</b>	P, S, M



## LEXI 3

Jet Black (gloss) (BLK).

<b>FRAME</b>	Lexi, 120 mm, SmartFormed Alloy, BB30, 1.5 Si headtube	<b>SHIFTERS</b>	Shimano Deore	<b>BRAKES</b>	Shimano M486, 185/160 mm, hydraulic disc
<b>SUSPENSION (R/F)</b>	X Fusion 02 RL2/RST Deuce Air, 120 mm	<b>REAR DERAILLEUR</b>	Shimano Deore, 10-speed	<b>TIRES</b>	Kenda Slant 6, 2.1", folding
<b>WHEELS</b>	Maddux DC 3.0, double wall w/eyelet, 28 hole	<b>CRANK</b>	Shimano M420, 44/32/22	<b>SIZES</b>	P, S, M

# FLASH WOMEN'S

*GO AHEAD, CHICK SOMEONE.*

*DON'T BE SHY ABOUT BLOWING RIGHT BY SOMEONE, WITH A SMILE ON YOUR FACE AND A POLITE "HEY, NICE RIDE". THEN YOU'RE GONE.*

## **SUPER LIGHT WEIGHT**

At 1450 grams, **Flash Alloy** is lighter than most of our competitor's carbon offerings.

## **CANNONDALE ALUMINUM**

Flash's sophisticated **SmartFormed** tubing manipulation and our trademark double pass smooth welds reflect our almost 30 years of aluminum supremacy.

## **SAVE MICRO SUSPENSION SYSTEM**

Careful shaping and wall thickness manipulation on the rear stays allows them to deflect vertically while remaining stiff laterally and torsionally, absorbing shock and enhancing control.



## **FLASH**

Jet Black (gloss) (BLK).

**FRAME** Flash Women's, SmartFormed Alloy, SAVE, BB30, 1.5 Si headtube

**SHIFTERS** SRAM X7

**BRAKES** Avid Elixir 3, 160/160 mm

**FORK** Fatty DLR80, 80 mm

**REAR DERAILLEUR** SRAM X9, 10-speed

**TIRES** Kenda Small Block 8, 2.1"

**WHEELS** Maddux DC 3.0, double wall w/eyelet, 28 hole

**CRANK** FSA Comet 386 BB30, 39/27

**SIZES** P, S, M, T

# TRAIL SL/TRAIL WOMEN'S

**BLAZE YOUR OWN TRAIL.**

**THIS IS WHERE YOU START.  
WHERE YOUR TRAIL TAKES YOU  
AFTER THAT IS UP TO YOU.**

## GO CONFIDENTLY

Our Women's **Trail** is crafted with attention to the details that women riders need such as a lower standover height for increased confidence, lighter suspension springs for lighter riders and stable handling for a reassuring ride.

## ALUMINUM CRAFTING

**Trail** and **Trail SL**'s mechanically formed aluminum and our trademark double pass smooth welds highlight Cannondale's aluminum expertise.

## SAVE MICRO SUSPENSION SYSTEM

Optimized chain stay and seat stay shaping provides lateral rigidity while providing vertical compliance for bump absorption and comfort with no loss in power transfer.



## TRAIL SL 2

Magnesium White (gloss) (WHT).

**FRAME** Trail SL Women's, Optimized 6061 alloy, SAVE, 1.5" headtube

**FORK** RockShox Recon Silver TK, 100 mm

**WHEELS** Maddux DC 3.0, double wall w/eyelet, 28 hole

**SHIFTERS** Shimano Alivio

**REAR DERAILLEUR** Shimano Deore, 9 speed

**CRANK** Shimano M420, 44/32/22

**BRAKES** Shimano M445 hydraulic disc, 160/160 mm

**TIRES** Kenda Small Block 8, 2.1"

**SIZES** P, S, M, T



### TRAIL SL 3

Cabernet (matte) (CAB).

**FRAME** Trail SL Women's, Optimized 6061 alloy, SAVE, 1.5" headtube  
**FORK** RST Deuce Coil, 100 mm, softer spring  
**WHEELS** Maddux DC 3.0, double wall w/eyelet, 28 hole

**SHIFTERS** SRAM X5  
**REAR DERAILLEUR** SRAM X5, 9-speed  
**CRANK** Shimano M420, 44/32/22



Pearl White (gloss) (WHT).

**BRAKES** Tektro Draco SL hydraulic disc, 160/160 mm  
**TIRES** Kenda Small Block 8, 2.1"  
**SIZES** P, S, M, T



### TRAIL 5

Fine Silver (matte) (SLV).

**FRAME** Trail, double butted 6061 alloy, SAVE, 1-1/8" headtube  
**FORK** RST Gila Pro TNL, 100 mm, softer spring  
**WHEELS** Alex DC 4.5, double wall, 28 hole

**SHIFTERS** Shimano Alivio  
**REAR DERAILLEUR** Shimano Alivio, 8-speed  
**CRANK** Shimano M311, 44/32/22



Jet Black (gloss) (BLK).

**BRAKES** Promax CD7.0 mechanical disc, 160/160 mm  
**TIRES** Kenda Small Block 8, 2.1"  
**SIZES** P, S, M, T



### TRAIL 6

Goodnight Green (matte) (GRN).

**FRAME** Trail, double butted 6061 alloy, SAVE, 1-1/8" headtube  
**FORK** RST Gila T, 80 mm, softer spring  
**WHEELS** Alex DC 4.5, double wall, 28 hole

**SHIFTERS** Shimano M310, trigger w/optical display  
**REAR DERAILLEUR** Shimano Acera, 8 speed  
**CRANK** Shimano M311, 42/32/22



Magnesium White (gloss) (WHT).

**BRAKES** Tektro Novela, mechanical disc, 160/160 mm  
**TIRES** Kenda Small Block 8, 2.1"  
**SIZES** P, S, M, T



# SUPERSIX WOMEN'S



## SUPERSIX 1 DURA-ACE

**FRAME** SuperSix Carbon Women's, BB30

**FORK** SuperSix, full carbon, 1-1/8"-1.5" steerer, alloy dropouts

**WHEELS** Mavic Ksyrium Elite

**SHIFTERS** Shimano Dura-Ace 7900

**REAR DERAILLEUR** Shimano Dura-Ace 7900

**CRANK** FSA SL-K Light Carbon Compact, 50/34

Uni-Directional Carbon (matte) (CRB).

**BRAKES** Shimano Dura-Ace 7900

**TIRES** Schwalbe Durano S, 700 x 23c, folding

**SIZES** 44, 48, 51, 54cm

**BEATING THE BOYS NEVER LOOKED SO GOOD.**

**FOR WOMEN RACERS EVERYWHERE.  
WOMEN WHO LIVE TO PIN ON A NUMBER.  
WOMEN WHO LIVE TO GO FAST.  
WOMEN WHO FIT TRAINING INTO LIFE.  
SUPERSIX IS OUR SALUTE TO YOU.**



**1 POWER TRANSFER  
BEATBOX**

Massively oversized **Beatbox** BB area paired with super-stiff and light **BB30** system delivers the torsional rigidity needed to turn the twisting loads from the cranks into forward momentum.

**2 HOURLASS STAYS**

**Hourglass** stays allow the vertical compliance necessary to maintain confident control over less-than-perfect surfaces, and the comfort required to deliver maximum performance after long days in the saddle.

**3 ULTIMATE CONTROL**

Deep radius head tube and 1-1/8" to 1-1/2" tapered carbon steerer fork provide maximum torsional stiffness for precise steering and wicked sprinting. Molded carbon headset cups replace aluminum for weight savings.





## SUPER SIX 3 ULTEGRA

Magnesium White (gloss) (WHT).

**FRAME** SuperSix Carbon Women's, BB30

**FORK** SuperSix, full carbon, 1-1/8"-1.5" steerer, alloy dropouts

**WHEELS** Mavic Ksyrium Equipe

**SHIFTERS** Shimano Ultegra 6700

**REAR DERAILLEUR** Shimano Ultegra 6700

**CRANK** FSA SL-K Light Carbon Compact, 50/34

**BRAKES** Shimano Ultegra 6700

**TIRES** Schwalbe Durano S, 700 x 23c, folding

**SIZES** 44, 48, 51, 54cm



## SUPER SIX 5 105

Jet Black (gloss) (BLK).

**FRAME** SuperSix Carbon Women's, BB30

**FORK** SuperSix, full carbon, 1-1/8"-1.5" steerer, alloy dropouts

**WHEELS** Shimano RS10

**SHIFTERS** Shimano 105 5700

**REAR DERAILLEUR** Shimano 105 5700

**CRANK** FSA Gossamer Pro BB30 Compact, 50/34

**BRAKES** Shimano 105 5700

**TIRES** Schwalbe Lugano, 700 x 23c, folding

**SIZES** 44, 48, 51, 54cm

# CAAD10 WOMEN'S

PERFORMANCE TO THE POWER OF X(X).

IF YOU'RE LOOKING FOR AN ALUMINUM FRAME THAT PUTS MOST CARBON FRAMES TO SHAME, CAAD10 IS THE ANSWER.

## RIDE ALL DAY

SAVE rear stays are shaped and butted to create a micro-suspension system which absorbs road shock without losing power. Wide seat stay spacing at top tube junction also improves lateral stiffness.

## SUPERLIGHT CAAD10 FORK

Housed in our externally machined, tapered headtube, the superlight 1-1/8" to 1-1/4" tapered carbon steerer fork features offset dropouts, allowing more fork angle for increased comfort without affecting the razor sharp handling.

## WOMEN'S GEOMETRY

We strongly believe that your bike shouldn't limit your riding, so we designed CAAD10 with details like a taller head tube to balance women's proportionately higher saddle height, shorter reach and a fork rake that minimizes toe overlap.



## CAAD10 4 RIVAL

Brushed Aluminum (gloss) (RAW).

Magnesium White w/Ruby Red (gloss) (WHT).

**FRAME** CAAD10 Women's, SmartFormed 6069 alloy, BB30

**SHIFTERS** SRAM Rival w/reach adjust

**BRAKES** SRAM dual pivot

**FORK** CAAD10, full carbon, 1-1/8"-1-1/4" steerer

**REAR DERAILLEUR** SRAM Rival

**TIRES** Schwalbe Lugano, 700 x 23c, folding

**WHEELS** Shimano RS10

**CRANK** SRAM Force Carbon BB30 Compact, 50/34

**SIZES** 44, 48, 51, 54cm



Adam Coppola



## CAAD10 5 105

**FRAME** CAAD10 Women's, SmartFormed 6069 alloy, BB30

**FORK** CAAD10, full carbon, 1-1/8"-1-1/4" steerer

**WHEELS** Shimano RS10

**SHIFTERS** Shimano 105 5700

**REAR DERAILLEUR** Shimano 105 5700

**CRANK** FSA Gossamer Pro BB30 Compact, 50/34

Jet Black (gloss) (BLK).

Magnesium White w/Berserker Green Pearl (gloss) (WHT).

**BRAKES** Tektro R580, dual pivot, cartridge pad

**TIRES** Schwalbe Lugano, 700 x 23c, folding

**SIZES** 44, 48, 51, 54cm

# SLICE WOMEN'S

**THE BEST MULTISPORT BIKE IN THE WORLD. IN YOUR SIZE.**

**THE SLICE HELPED CHRISSIE WELLINGTON AND MIRINDA CARFRAE DOMINATE THE 2009 IRONMAN WORLD CHAMPIONSHIPS, COMFORTABLY SETTING COURSE RECORDS IN THE PROCESS. GET READY TO DOMINATE.**

## RIDE SMOOTHER. RUN FRESHER

Aerodynamics aren't worth a thing if you can't maintain the aero position or are too beat up to run. Slice's SAVE rear stay micro-suspension system deflects vertically to absorb road shock while staying extremely stiff laterally and torsionally.

## CONFIDENT HANDLING

Unlike the nervous, twitchy handling of some aero frames, the Slice's geometry is designed to provide stable and confidence-inspiring handling while in the aero position, allowing you to relax and focus on your ride.

## RINNY'S ROCKETSHIP

So that more riders can benefit from the speed and light weight of the Slice we've added a size 47, equipped with 650c wheels. Mirinda loves it!



## SLICE 4 RIVAL

Magnesium White (gloss) (WHT).

**FRAME** Slice Carbon Women's, SAVE, BB30

**SHIFTERS** SRAM 1090 R2C

**BRAKES** SRAM dual pivot

**FORK** Slice Aero, full carbon

**REAR DERAILLEUR** SRAM Rival

**TIRES** Schwalbe Lugano, 700 x 23c

**WHEELS** Mavic Kysium Equipe (650c, 700c)

**CRANK** FSA Trimax Pro BB30, 52/38

**SIZES** 47 (650c), 51, 54cm



Eric Wynn



## SLICE 5 105

Magnesium White (gloss) (WHT).

**FRAME** Slice Carbon Women's, SAVE, BB30

**SHIFTERS** MicroShift, Shimano compatible

**BRAKES** Tektro R520 w/cartridge pads

**FORK** Slice Aero, full carbon

**REAR DERAILLEUR** Shimano 105 5700

**TIRES** Schwalbe Lugano, 700 x 23c, folding

**WHEELS** Maddux Aero G40 (650c, 700c)

**CRANK** FSA Gossamer Pro BB30 Compact, 50/34 (51-54cm), 53/39 (47cm)

**SIZES** 47 (650c), 51, 54cm



# SYNAPSE WOMEN'S

PERFORMANCE MEETS COMFORT.

DISCOVER THAT THERE ARE  
NO LIMITS TO WHAT YOU CAN DO.

## AWARD-WINNING

Word is getting around: **Synapse's** comfort and performance features were recognized by the cogniscenti of *Bicycling* magazine when it beat out a field of competitors to win the Editors' Choice Best Women's Road Bike award.

## PERFORMANCE GEOMETRY

A taller head tube than the Women's **SuperSix**, a longer wheelbase and relaxed angles produce a more upright riding position and a confidence-inspiring ride which avoids the sluggish feel of many "comfort" road bikes.

## SAVE MICRO SUSPENSION SYSTEM

Careful shaping and carbon layup of the rear stays and fork blades absorb road shock and vibration while staying extremely rigid laterally for power transfer and confident cornering.



## SYNAPSE HI-MOD 1 DURA-ACE

Jet Black, Magnesium White (gloss) (BLK).

**FRAME** Synapse Women's, Hi-MOD, SAVE, BB30

**SHIFTERS** Shimano Dura-Ace 7900

**BRAKES** Shimano Dura-Ace 7900

**FORK** Synapse, Hi-MOD full carbon, SAVE, 1-1/8"

**REAR DERAILLEUR** Shimano Dura-Ace 7900

**TIRES** Schwalbe Ultramo ZX, 700 x 25c, folding

**WHEELS** Mavic Ksyrium SL

**CRANK** FSA SL-K Carbon Light BB30 Compact, 50/34

**SIZES** 44, 48, 51, 54cm





## SYNAPSE CARBON 3 ULTEGRA

Indigo Blue, Fine Silver (gloss) (BLU).

**FRAME** Synapse Carbon Women's, SAVE, BB30

**SHIFTERS** Shimano Ultegra 6700

**BRAKES** Shimano Ultegra 6700

**FORK** Synapse, full carbon, SAVE, alloy dropouts, 1-1/8"

**REAR DERAILLEUR** Shimano Ultegra 6700

**TIRES** Schwalbe Durano, 700 x 25c, folding

**WHEELS** Shimano RS80

**CRANK** FSA SL-K Carbon Light BB30 Compact, 50/34

**SIZES** 44, 48, 51, 54cm



## SYNAPSE CARBON 4 RIVAL

Cabernet, Magnesium White (gloss) (CAB).

Magnesium White, Jet Black, Ruby Red (gloss) (WHT).

**FRAME** Synapse Carbon Women's, SAVE, BB30

**SHIFTERS** SRAM Rival w/Reach Adjust

**BRAKES** SRAM dual pivot

**FORK** Synapse, full carbon, SAVE, alloy dropouts, 1-1/8"

**REAR DERAILLEUR** SRAM Rival WiFLi

**TIRES** Schwalbe Durano, 700 x 25c, folding

**WHEELS** Mavic Aksium Race

**CRANK** FSA Gossamer Pro BB30 Compact, 50/34

**SIZES** 44, 48, 51, 54cm





## SYNAPSE CARBON 5 105

Orange Spice, Magnesium White (gloss) (ORG).

Magnesium White, Jet Black, Ruby Red (gloss) (WHT).

**FRAME** Synapse Carbon Women's, SAVE, BB30

**SHIFTERS** Shimano 105 5700

**BRAKES** Shimano 105 5700

**FORK** Synapse, full carbon, SAVE, alloy dropouts, 1-1/8"

**REAR DERAILLEUR** Shimano 105 5700

**TIRES** Schwalbe Lugano, 700 x 25c, folding

**WHEELS** Shimano RS10

**CRANK** FSA Gossamer Pro BB30 Compact, 50/34

**SIZES** 44, 48, 51, 54cm



## SYNAPSE CARBON 6 APEX

Charcoal Grey, Pearl White (gloss) (GRY).

Magnesium White, Jet Black, Blue (gloss) (WHT).

**FRAME** Synapse Carbon Women's, SAVE

**SHIFTERS** SRAM Apex

**BRAKES** SRAM Apex

**FORK** Synapse, full carbon, SAVE, alloy dropouts, 1-1/8"

**REAR DERAILLEUR** SRAM Apex WFLi

**TIRES** Schwalbe Lugano, 700 x 25c

**WHEELS** Shimano R500A

**CRANK** SRAM S150 Compact, 50/34

**SIZES** 44, 48, 51, 54cm

# SYNAPSE ALLOY WOMEN'S

**FIND YOUR INNER CYCLIST.**

**WHETHER YOU'RE TEMPTED BY THE LURE OF COMMUTING, THAT LONG-PROMISED CHARITY RIDE OR A LATE SUMMER WOMEN'S-ONLY TRIATHLON, SYNAPSE IS THE ANSWER.**

## CANNONDALE ALUMINUM

Modeled after our award-winning Synapse Carbon, Synapse Alloy features our sophisticated tubing manipulation and trademark double pass smooth welds. Strong and super light.

## SPORTING VERSATILITY

Synapse Alloy's rack mounts and fender clearance expand its versatility to commuting and lightweight touring without sacrificing its sporting soul. Put this baby to work!

## ENJOY THE RIDE

Synapse' light and efficient alloy frame makes climbing a delight while it's stable and reliable geometry brings out the fun of descending.



FSA Gossamer BB30 Triple, 52/39/30

## SYNAPSE ALLOY 5 105

Brushed Aluminum (gloss) (RAW).

Magnesium White (gloss) (WHT).

**FRAME** Synapse Women's, Optimized 6061 alloy, SAVE, BB30

**SHIFTERS** Shimano 105 5700

**BRAKES** Tektro R538, long reach, cartridge pads

**FORK** Synapse, SAVE, carbon blades, 1-1/8"

**REAR DERAILLEUR** Shimano 105 5700

**TIRES** Schwalbe Lugano, 700 x 25c

**WHEELS** Shimano RS10

**CRANK** FSA Gossamer BB30 Compact, 50/34

**SIZES** 44, 48, 51, 54cm



Shimano Tiagra Triple, 50/39/30



## SYNAPSE ALLOY 6 TIAGRA

Pearl White (gloss) (WHT).

Jet Black (gloss) (BLK).

**FRAME** Synapse Women's, Optimized 6061 alloy, SAVE

**SHIFTERS** Shimano Tiagra

**BRAKES** Cannondale C4 w/cartridge pads

**FORK** Synapse, SAVE, carbon blades, 1-1/8"

**REAR DERAILLEUR** Shimano Tiagra

**TIRES** Schwalbe Lugano, 700 x 25c

**WHEELS** Maddux R3.0, 28 hole

**CRANK** Shimano Tiagra Compact, 50/34

**SIZES** 44, 48, 51, 54cm



FSA Vero, 50/39/30



## SYNAPSE ALLOY 7 SORA

Egyptian Blue (gloss) (BLU).

Magnesium White (gloss) (WHT).

**FRAME** Synapse Women's, Optimized 6061 alloy, SAVE

**SHIFTERS** Shimano Sora

**BRAKES** Cannondale C4 w/cartridge pads

**FORK** Synapse, SAVE, carbon blades, 1-1/8"

**REAR DERAILLEUR** Shimano Sora

**TIRES** Schwalbe Lugano, 700 x 25c

**WHEELS** Maddux R3.0, 28 hole

**CRANK** FSA Vero Compact, 50/34

**SIZES** 44, 48, 51, 54cm

# QUICK WOMEN'S

**QUICK: IT'S YOUR TIME.**

**SPEEDY COMMUTER. OUTDOOR GYM.  
TWO-WHEELED FREEDOM.**

## HEADS-UP RIDING

**Quick** geometry delivers an upright riding position for increased comfort, visibility and enjoyment. Relax and enjoy the ride.

## ALL DAY COMFORT

**SAVE** rear stays are shaped to absorb road vibration, increase comfort and enhance control.

## MADE FOR YOU

We design bikes to account for women's shorter torsos and longer legs. This translates into a shorter top tube for your shorter reach, a taller head tube to balance proportionately taller seat height, and a fork rake which minimizes toe overlap, to name a few.



## QUICK CARBON 1

Uni-directional Carbon (matte) (CRB).

**FRAME** Quick full carbon Women's, BB30

**SHIFTERS** Shimano SL-770

**BRAKES** TRP CX9 Mini-V w/cartridge pads

**FORK** Quick, full carbon, Si

**REAR DERAILLEUR** Shimano Ultegra 6700, 10-speed

**TIRES** Kenda Kwick Roller Sport, 700 x 28c

**WHEELS** Formula XERO Element CXR

**CRANK** FSA SLK Light BB30 Compact, 50/34

**SIZES** S, T



Chris Milliman



## QUICK CARBON 2

**FRAME** Quick full carbon Women's, BB30

**FORK** Quick, full carbon, Si

**WHEELS** Formula XERO Element CXR

**SHIFTERS** Shimano SL-770

**REAR DERAILLEUR** Shimano 105 5700, 10-speed

**CRANK** FSA Gossamer Pro BB30 Triple, 52/39/30

Uni-directional Carbon (matte) (CRB).

**BRAKES** TRP CX9 Mini-V w/cartridge pads

**TIRES** Kenda Kwick Roller Sport, 700 x 28c

**SIZES** S, T





### QUICK 1

Brushed Aluminum (gloss) (RAW).

**FRAME** Quick SL Women's, Optimized 6061 alloy, SAVE

**SHIFTERS** Shimano SL-770

**BRAKES** Tektro RX5 Mini V-Brakes

**FORK** Quick, carbon blades, 1-1/8" steerer

**REAR DERAILLEUR** Shimano 105 5700, 10-speed

**TIRES** Continental Sport Contact, 700 x 32c

**WHEELS** Element Xero C2

**CRANK** Shimano 105 5700 triple, 30/39/50

**SIZES** P, S, T



### QUICK 2

Carbernet (gloss) (CAB).

**FRAME** Quick SL Women's, Optimized 6061 alloy, SAVE

**SHIFTERS** Shimano SL-R440

**BRAKES** Tektro RX5 Mini V-Brakes

**FORK** Quick, carbon blades, 1-1/8" steerer

**REAR DERAILLEUR** Shimano Tiagra, 9-speed

**TIRES** Continental Sport Contact, 700 x 32c

**WHEELS** Element Xero C3

**CRANK** Shimano Tiagra triple, 30/39/50

**SIZES** XS (26"), P, S, T



### QUICK 3

Jet Black (gloss) (BLK).

**FRAME** Quick SL Women's, Optimized 6061 alloy, SAVE

**SHIFTERS** Shimano Alivio

**BRAKES** Tektro RX1 Mini V-Brakes

**FORK** Quick, carbon blades, 1-1/8" steerer

**REAR DERAILLEUR** Shimano Deore, 9-speed

**TIRES** Continental City Contact, 700 x 32c

**WHEELS** Element Xero C3

**CRANK** Shimano M431, 26/36/48

**SIZES** P, S, T



Magnesium White (gloss) (WHT).



Fine Silver (matte) (SLV).



Pearl White (gloss) (WHT).

### QUICK 4

**FRAME** Quick Women's, double butted 6061 alloy, SAVE

**FORK** Quick, carbon blades, 1-1/8" steerer

**WHEELS** Element Xero C3

**SHIFTERS** Shimano Alivio

**REAR DERAILLEUR** Shimano Alivio, 8-speed

**CRANK** Shimano M131, 28/38/48

**BRAKES** Tektro TX 120 V-Brakes

**TIRES** Kenda Kwick Trax, 700 X 38c

**SIZES** XS (26"), P, S, T



Egyptian Blue (gloss) (BLU).



Pearl White (gloss) (WHT).

### QUICK 5

**FRAME** Quick Women's, double butted 6061 alloy, SAVE

**FORK** Quick, carbon blades, 1-1/8" steerer

**WHEELS** Jalco DT 21

**SHIFTERS** Shimano Acera

**REAR DERAILLEUR** Shimano Alivio, 8-speed

**CRANK** Shimano M131, 28/38/48

**BRAKES** Tektro TX 120 V-Brakes

**TIRES** Kenda Kwick Trax, 700 X 38c

**SIZES** P, S, T



# ADVENTURE WOMEN'S

**GO GRACEFULLY.**

**CRUISING THE GREENWAY WITH FRIENDS, PICKING UP FRESH BREAD AT THE FARMERS MARKET OR A SPIN ACROSS TOWN TO CHECK OUT THE CHERRY BLOSSOMS. WHAT'S YOUR ADVENTURE?**

## **RIDER-TAILORED GEOMETRY**

**Adventure** has our most upright rider posture aimed at maximum comfort without being sluggish. We also ensure that at the correct seat height the rider can still touch the ground comfortably without losing the ability to ride efficiently.

## **LUXURIOUS TRAPPINGS**

Soft touch grips and quick release levers combined with a super plush sprung saddle give the **Adventure** a luxurious feel.

## **STEP THROUGH FRAME**

For the ultimate in convenience **Adventure** also comes in a reassuring **Step Through** frame design.



## **ADVENTURE 1**

Magnesium White (gloss) (WHT).

**FRAME** Adventure Women's, double butted 6061 alloy

**SHIFTERS** Shimano Nexus twist type

**BRAKES** Cannondale V Brake w/modulator

**FORK** Adventure Trail Si suspension, 35 mm

**REAR HUB** Shimano Nexus Premium 8-speed internal rear

**TIRES** Kenda Kwick Trax, 700 x 38c

**WHEELS** Cannondale C3, double wall, alloy

**CRANK** FSA Single Ring, 38

**SIZES** S, T



## ADVENTURE 2

Cabernet (gloss) (CAB).

Fine Silver (gloss) (SLV).

**FRAME** Adventure Women's, double butted 6061 alloy

**SHIFTERS** Shimano Revo twist type

**BRAKES** Cannondale V Brake w/modulator

**FORK** Adventure Trail Si suspension, steel, 35 mm

**REAR DERAILLEUR** Shimano Alivio, 8-speed

**TIRES** Kenda Kwick Trax, 700 x 38c

**WHEELS** Cannondale C3, double wall, alloy

**CRANK** Shimano M191, 48/38/28

**SIZES** S, T



## ADVENTURE 3

Jet Black (gloss) (BLK).

Pearl White (gloss) (WHT).

**FRAME** Adventure Women's, double butted 6061 alloy

**SHIFTERS** Shimano Revo twist type

**BRAKES** Cannondale V Brake w/modulator

**FORK** RST Sofi T, 50 mm

**REAR DERAILLEUR** Shimano Acera, 8-speed

**TIRES** Kenda Kwick Trax, 700 x 38c

**WHEELS** Cannondale C3, double wall, alloy

**CRANK** Shimano M191, 48/38/28

**SIZES** S, T



## ADVENTURE 3-26"

Pearl White (gloss) (WHT).

Jet Black (gloss) (BLK).

**FRAME** Adventure Women's, double butted 6061 alloy, for 26" wheels, step thru

**SHIFTERS** Shimano Revo twist type

**BRAKES** Cannondale V Brake w/modulator

**FORK** RST Sofi T 26", 50 mm

**REAR DERAILLEUR** Shimano Acera, 8-speed

**TIRES** Kenda NPJ signature, 26 x 1.25"

**WHEELS** Cannondale C3, double wall, alloy, 26"

**CRANK** Shimano M191, 48/38/28

**SIZES** S, T



	<b>SUPERSIX 1 DURA-ACE</b>	<b>SUPERSIX 3 ULTEGRA</b>	<b>SUPERSIX 5 105</b>	<b>CAAD10 4 RIVAL</b>	<b>CAAD10 5 105</b>
<b>Code</b>	1RWS1C	1RWS3C	1RWS5C	1RWX4C	1RWX5C
<b>Frame</b>	SuperSix Women's, full carbon, BB30, SAVE	SuperSix Women's, full carbon, BB30, SAVE	SuperSix Women's, full carbon, BB30, SAVE	CAAD10 Women's, Smartformed 6069 Alloy, SAVE, BB30	CAAD10 Women's, Smartformed 6069 Alloy, SAVE, BB30
<b>Fork</b>	SuperSix, full carbon, 1-1/8"-1.5" tapered steerer, alloy dropouts	SuperSix, full carbon, 1-1/8"-1.5" tapered steerer, alloy dropouts	SuperSix, full carbon, 1-1/8"-1.5" tapered steerer, alloy dropouts	CAAD10, full carbon, 1-1/8" to 1-1/4" tapered steerer	CAAD10, full carbon, 1-1/8" to 1-1/4" tapered steerer
<b>Rims</b>	Mavic Ksyrium Elite	Mavic Ksyrium Equipe	Shimano RS10	Shimano RS10	Shimano RS10
<b>Hubs</b>	Mavic Ksyrium Elite	Mavic Ksyrium Equipe	Shimano RS10	Shimano RS10	Shimano RS10
<b>Spokes</b>	Mavic Ksyrium Elite	Mavic Ksyrium Equipe	Shimano RS10	Shimano RS10	Shimano RS10
<b>Tires</b>	Schwalbe Ultrero Zx, 700 x 23c, folding	Schwalbe Durano S, 700 x 23c, folding	Schwalbe Lugano, 700 x 23c, folding	Schwalbe Lugano, 700 x 23c, foldable	Schwalbe Lugano, 700 x 23c, foldable
<b>Pedals</b>	N/A	N/A	N/A	N/A	N/A
<b>Crank</b>	FSA SL-K Light Carbon BB30, 50/34	FSA SL-K Light Carbon BB30, 50/34	Shimano 105 5700	SRAM Force Carbon, BB30, 50/34	FSA Gossamer Pro BB30, 50/34
<b>Bottom Bracket</b>	FSA BB30	FSA BB30	Shimano 105 5700, 11-28	SRAM BB30	FSA BB30
<b>Chain</b>	Shimano Dura-Ace 7900	Shimano Ultegra	Shimano 105 5700, 34.9 mm clamp	KMC DX-10SC	Shimano 105 5700
<b>Rear Cogs</b>	Shimano Dura-Ace 7900, 11-28	Shimano Ultegra 6700, 11-28	Shimano 105 5700	SRAM PG-1070, 11-28	Shimano 105 5700, 11-28
<b>Front Derailleur</b>	Shimano Dura-Ace 7900, 34.9 mm clamp	Shimano Ultegra 6700, 34.9 mm clamp	Shimano 105 5700	SRAM Rival	Shimano 105 5700, 34.9 mm clamp
<b>Rear Derailleur</b>	Shimano Dura-Ace 7900	Shimano Ultegra 6700	Shimano 105	SRAM Rival	Shimano 105 5700
<b>Shifters</b>	Shimano Dura-Ace 7900	Shimano Ultegra 6700	Shimano 105	SRAM Rival w/reach adjust	Shimano 105 5700
<b>Handlebar</b>	FSA SL-K Wing Compact, Carbon	Cannondale C2 Women's Compact Wing, AI-7050, Butted	Cannondale C3 Women's Compact Wing, AI-6061 Butted	Cannondale C3 Women's Compact Wing, AI-6061 Butted	Cannondale C3 Women's Compact, AI-6061 Butted
<b>Stem</b>	FSA SL-K, 6 degree, 31.8	Cannondale C2, 6 degree, 31.8	Cannondale C3, 6 degree, 31.8	Cannondale C3, 6 degree, 31.8	Cannondale C3, 6 degree, 31.8
<b>Headset</b>	SuperSix, 1.5 lower bearing, 30 mm carbon w/5 mm hidden alloy top cover	SuperSix, 1.5 lower bearing, 30 mm carbon, w/5 mm hidden alloy top cover	SuperSix, 1.5 lower bearing, 30 mm alloy, w/5 mm hidden top cover	CAAD10, 1-1/4" lower bearing, 25 mm carbon top cap	CAAD10, 1-1/4" lower bearing, 25 mm carbon top cap
<b>Brakes</b>	Shimano Dura-Ace 7900	Shimano Ultegra 6700	Shimano 105 5700	SRAM Caliper w/SwissStop brake pads	Tektro R580, dual pivot, cartridge pad
<b>Brake Levers</b>	Shimano Dura-Ace 7900	Shimano Ultegra 6700	Shimano 105 5700	SRAM Rival w/reach adjust	Shimano 105 5700
<b>Saddle</b>	Fi'zi:k Vesta, Kium rails	Fi'zi:k Vesta, Manganese rails	Prologo Kappa Dea, ProT 2.0 rails	Prologo Kappa Dea, ProT 2.0 rails	Prologo Kappa Dea, ProT 2.0 rails
<b>Seatpost</b>	FSA SLK Carbon SP-RK-260, 31.6 mm, 350 mm	Cannondale C2, UD Carbon, 31.6 mm, 300 mm	Cannondale C2, UD Carbon, 31.6 mm, 300 mm	Cannondale C2, UD Carbon, 31.6 mm, 300 mm	Cannondale C3, Carbon wrap, 27.2 mm, 300 mm
<b>Sizes</b>	44, 48, 51, 54cm	44, 48, 51, 54cm	44, 48, 51, 54cm	44, 48, 51, 54cm	44, 48, 51, 54cm
<b>Color 1 (code)</b>	Uni-Directional Carbon (matte) (CRB).	Magnesium White (gloss) (WHT).	Jet Black (gloss) (BLK).	Brushed Aluminum (gloss) (RAW).	Jet Black (gloss) (BLK).
<b>Color 2 (code)</b>				Magnesium White w/Ruby Red (gloss) (WHT).	Magnesium White w/Berserker Green Pearl (gloss) (WHT).
<b>Extras</b>	Velo 2.5 mm Suede w/gel backing	Velo 2.5 mm Suede w/gel backing	Velo 2.5 mm Suede w/gel backing	Velo 2.5 mm Suede w/gel backing	Velo 2.5 mm Suede w/gel backing

	<b>SLICE 4 RIVAL</b>	<b>SLICE 5 105</b>	<b>SYNAPSE HI-MOD 1 DURA-ACE</b>	<b>SYNAPSE CARBON 3 ULTEGRA</b>	<b>SYNAPSE CARBON 4 RIVAL</b>
<b>Code</b>	1RWM4D	1RWM5C	1RWL1C	1RWC3C	1RWC4C
<b>Frame</b>	Slice Women's, full carbon, SAVE, BB30	Slice Women's, full carbon, SAVE, BB30	Synapse Women's, Hi-MOD full carbon, SAVE, BB30	Synapse Women's, full carbon, SAVE, BB30	Synapse Women's, full carbon, SAVE, BB30
<b>Fork</b>	Slice Aero, full carbon, 1-1/8"	Slice Aero, full carbon, 1-1/8"	Synapse, Hi-MOD full carbon, SAVE, 1-1/8"	Synapse, full carbon, SAVE, 1-1/8"	Synapse, full carbon, SAVE, 1-1/8"
<b>Rims</b>	Mavic Ksyrium Equipe (650c, 700c)	Maddux Aero G40 (650c, 700c)	Mavic Ksyrium SL	Shimano RS80	Mavic Aksium Race
<b>Hubs</b>	Mavic Ksyrium Equipe	Formula RB51, 24 hole front, Formula RB52, 28 hole rear	Mavic Ksyrium SL	Shimano RS80	Mavic Aksium Race
<b>Spokes</b>	Mavic Ksyrium Equipe	DT Swiss Champion	Mavic Ksyrium SL	Shimano RS80	Mavic Aksium Race
<b>Tires</b>	Schwalbe Lugano, 700 x 23c, folding / Maxxis Xenith, 650 x 23c, folding	Schwalbe Lugano, 700 x 23c, folding / Maxxis Xenith, 650 x 23c, folding	Schwalbe Ultrero ZX, 700 x 25c, folding	Schwalbe Durano, 700 x 25c, folding	Schwalbe Durano, 700 x 25c, folding
<b>Pedals</b>	N/A	N/A	N/A	N/A	N/A
<b>Crank</b>	FSA Trimax Pro BB30, 52/38	FSA Gossamer Pro BB30, 50/34 (650c, 53/39)	FSA SL-K Carbon Light BB30, 50/34	FSA SL-K Carbon Light BB30, 50/34	FSA Gossamer Pro BB30, 50/34
<b>Bottom Bracket</b>	FSA BB30	FSA BB30	FSA BB30	FSA BB30	FSA BB30
<b>Chain</b>	KMC DX-10SC	Shimano 105 5700	Shimano Dura-Ace 7900	Shimano Ultegra 6700	KMC DX-10SC w/missing link
<b>Rear Cogs</b>	SRAM PG-1070, 11-26	Shimano 105 5700, 11-28	Shimano Dura-Ace 7900, 11-28	Shimano Ultegra 6700, 11-28	SRAM PG-1050, 11-32
<b>Front Derailleur</b>	SRAM Rival	Shimano 105 5700, braze-on	Shimano Dura-Ace 7900, braze-on	Shimano Ultegra 6700, braze-on	SRAM Rival
<b>Rear Derailleur</b>	SRAM Rival	Shimano 105 5700	Shimano Dura-Ace 7900	Shimano Ultegra 6700	SRAM Rival WiFLi
<b>Shifters</b>	SRAM RTC TT 1090	Microshift Shimano-compatible bar-end	Shimano Dura-Ace 7900	Shimano Ultegra 6700	SRAM Rival w/Reach Adjust
<b>Handlebar</b>	3T Aura Carbon, 40 cm	Cannondale C3 Aero bar, 31.8, w/Profile T2 clip-ons	3T Ergonova Team Carbon	3T Ergonova Pro	3T Ergonova Pro
<b>Stem</b>	3T ARX Pro, 6 degree	Cannondale C3, 6 degree	3T ARX Team, 6 degree, 31.8	3T ARX Pro, 6 degree, 31.8	3T ARX Pro, 6 degree, 31.8
<b>Headset</b>	Slice, Si, 15 mm top cap	Slice, Si, 15 mm top cap	Synapse Si, 25 mm carbon top cap	Synapse Si, 25 mm carbon top cap	Synapse Si, 25 mm carbon top cap
<b>Brakes</b>	SRAM Caliper w/SwissStop brake pads	Tektro R520 w/cartridge pads	Shimano Dura-Ace 7900	Shimano Ultegra 6700	SRAM Caliper w/SwissStop brake pads
<b>Brake Levers</b>	Promax Aero	Promax Aero	Shimano Dura-Ace 7900	Shimano Ultegra 6700	SRAM Rival w/Reach Adjust
<b>Saddle</b>	Prologo Kappa Dea, ProT 2.0 rails	Prologo Kappa Dea, ProT 2.0 rails	Fi'zi:k Vesta, Kium rails	Fi'zi:k Vesta, Manganese rails	Prologo Kappa Dea, ProT 2.0 rails
<b>Seatpost</b>	Cannondale Slice Carbon Aero, 2 position, 350 mm	Cannondale Slice Carbon Aero, 2 position, 350 mm	Synapse SAVE Hi-MOD, 275 mm	Synapse SAVE carbon, 275 mm	Synapse SAVE carbon, 275 mm
<b>Sizes</b>	47 (650c), 51, 54cm	47 (650c), 51, 54cm	44, 48, 51, 54cm	44, 48, 51, 54cm	44, 48, 51, 54cm
<b>Color 1 (code)</b>	Magnesium White (gloss) (WHT).	Magnesium White (gloss) (WHT).	Jet Black, Magnesium White (gloss) (BLK).	Indigo Blue, Fine Silver (gloss) (BLU).	Cabernet, Magnesium White (gloss) (CAB).
<b>Color 2 (code)</b>					Magnesium White, Jet Black, Ruby Red (gloss) (WHT).
<b>Extras</b>	Seatpost water bottle mount, Velo 2.5 mm Suede w/gel backing	Seatpost water bottle mount, Velo 2.5 mm Suede w/gel backing	Velo 2.5 mm Suede w/gel backing	Velo 2.5 mm Suede w/gel backing	Velo 2.5 mm Suede w/gel backing



**QUICK 4**

<b>Code</b>	1QRW4
<b>Frame</b>	Quick Women's, butted 6061 alloy, SAVE
<b>Fork</b>	Quick, carbon blades, 1 1/8" steerer
<b>Rims</b>	Element Xero C3
<b>Hubs</b>	Element Xero C3
<b>Spokes</b>	Element Xero Stainless
<b>Tires</b>	Kenda Kwick Trax, 700 x 38c
<b>Pedals</b>	Quick Reinforced Composite w/Kraton, by Wellgo
<b>Crank</b>	Shimano M131, 28/38/48
<b>Bottom Bracket</b>	Tange Cartridge
<b>Chain</b>	KMC Z72, 8-speed
<b>Rear Cogs</b>	SunRace CSM668, 11-32
<b>Front Derailleur</b>	Shimano M191
<b>Rear Derailleur</b>	Shimano Alivio M410
<b>Shifters</b>	Shimano Alivio M410, 8-speed
<b>Handlebar</b>	Cannondale C4, 6061 alloy, 25 mm rise
<b>Stem</b>	Cannondale C4, 31.8
<b>Headset</b>	Tange Custom Si
<b>Brakes</b>	Tekro TX 120 V-Brakes
<b>Brake Levers</b>	Tekro R381A short reach w/Kraton insert
<b>Saddle</b>	Cannondale Quick Ergo Performance, Women's
<b>Seatpost</b>	Cannondale C4 6061 Alloy, 27.2 mm
<b>Sizes</b>	XS (26"), P, S, T
<b>Color 1 (code)</b>	Fine Silver (matte) (SLV).
<b>Color 2 (code)</b>	Pearl White (gloss) (WHT).
<b>Extras</b>	CannondaleErgo Performance grips

**QUICK 5**

<b>Code</b>	1QRW5
<b>Frame</b>	Quick Women's, butted 6061 alloy, SAVE
<b>Fork</b>	Quick, 6061 Alloy, 1 1/8" steerer
<b>Rims</b>	Jalco DT 21
<b>Hubs</b>	Formula RM21 front, FM22 rear
<b>Spokes</b>	Stainless 15g
<b>Tires</b>	Kenda Kwick Trax, 700 x 38c
<b>Pedals</b>	Quick Reinforced Composite w/Kraton, by Wellgo
<b>Crank</b>	Shimano M131, 28/38/48
<b>Bottom Bracket</b>	Tange Cartridge
<b>Chain</b>	KMC Z72, 8-speed
<b>Rear Cogs</b>	SunRace CSM668, 11-32
<b>Front Derailleur</b>	Shimano M191
<b>Rear Derailleur</b>	Shimano Alivio M410
<b>Shifters</b>	Shimano Alivio M310, 8-speed
<b>Handlebar</b>	Cannondale C4, 6061 alloy, 25 mm rise
<b>Stem</b>	Cannondale C4, 31.8
<b>Headset</b>	Tange Custom Si
<b>Brakes</b>	Tekro TX 120 V-Brakes
<b>Brake Levers</b>	Tekro R381A short reach w/Kraton insert
<b>Saddle</b>	Cannondale Quick Ergo Performance, Women's
<b>Seatpost</b>	Cannondale C4 6061 Alloy, 27.2 mm, 350 mm
<b>Sizes</b>	P, S, T
<b>Color 1 (code)</b>	Egyptian Blue (gloss) (BLU).
<b>Color 2 (code)</b>	Pearl White (gloss) (WHT).
<b>Extras</b>	CannondaleErgo Performance grips

**ADVENTURE 1**

<b>Code</b>	1ASW1
<b>Frame</b>	Adventure Women's step-thru, double butted 6061 alloy
<b>Fork</b>	Adventure Trail Si suspension, 35 mm, alloy 1-1/8" steerer
<b>Rims</b>	Cannondale C3, double wall, alloy
<b>Hubs</b>	Formula FM-21 front, Shimano Nexus Premium 8-speed internal rear
<b>Spokes</b>	Stainless, 15g
<b>Tires</b>	Kenda Kwick Trax, 700 x 38c
<b>Pedals</b>	FPD Resin w/Kraton Insert
<b>Crank</b>	FSA Single Ring, 38
<b>Bottom Bracket</b>	Tange cartridge type
<b>Chain</b>	KMC 8-speed
<b>Rear Cogs</b>	N/A
<b>Front Derailleur</b>	N/A
<b>Rear Derailleur</b>	N/A
<b>Shifters</b>	Shimano Nexus Twist Type
<b>Handlebar</b>	Women's Cannondale C4, 50 mm rise, alloy
<b>Stem</b>	Tranz X Comfort Grip, Tool-free Adjustment
<b>Headset</b>	FSA Semi Integrated
<b>Brakes</b>	Cannondale V Brake w/modulator
<b>Brake Levers</b>	Shimano Nexus, 4 finger
<b>Saddle</b>	Women's Cannondale Ultra Comfort
<b>Seatpost</b>	Cannondale Suspension, 40 mm travel
<b>Sizes</b>	S, T
<b>Color 1 (code)</b>	Magnesium White (gloss) (WHT).
<b>Color 2 (code)</b>	
<b>Extras</b>	Cannondale Ergo Lock-On grips, Tranz X Comfort Grip quick release skewers and quick release seat binder

**ADVENTURE 2**

<b>Code</b>	1ASW2
<b>Frame</b>	Adventure Women's step-thru, double butted 6061 alloy
<b>Fork</b>	Adventure Trail Si suspension, 35 mm, steel 1-1/8" steerer
<b>Rims</b>	Cannondale C3, double wall, alloy
<b>Hubs</b>	Formula FM-21 front, FM-22 rear
<b>Spokes</b>	Stainless, 15g
<b>Tires</b>	Kenda Kwick Trax, 700 x 38c
<b>Pedals</b>	FPD Resin w/Kraton Insert
<b>Crank</b>	Shimano M191, 48/38/28
<b>Bottom Bracket</b>	Tange cartridge type
<b>Chain</b>	KMC 8-speed
<b>Rear Cogs</b>	Sunrace CSM668, 11-32
<b>Front Derailleur</b>	Shimano M-191
<b>Rear Derailleur</b>	Shimano Alivio
<b>Shifters</b>	Shimano Revo Twist Type, 8-speed
<b>Handlebar</b>	Women's Cannondale C4, 50 mm rise, alloy
<b>Stem</b>	Tranz X Comfort Grip, Tool-free Adjustment
<b>Headset</b>	Tange Integrated
<b>Brakes</b>	Cannondale V Brake w/modulator
<b>Brake Levers</b>	Cannondale, 4 finger w/Kraton comfort insert
<b>Saddle</b>	Women's Cannondale Ultra Comfort
<b>Seatpost</b>	Cannondale Suspension, 40 mm travel
<b>Sizes</b>	S, T
<b>Color 1 (code)</b>	Cabernet (gloss) (CAB).
<b>Color 2 (code)</b>	Fine Silver (gloss) (SLV).
<b>Extras</b>	Cannondale Ergo Lock-On grips, Tranz X Comfort Grip quick release skewers and quick release seat binder

**ADVENTURE 3**

<b>Code</b>	1ASW3
<b>Frame</b>	Adventure Women's step-thru, double butted 6061 alloy
<b>Fork</b>	RST Sofi T, 50 mm, 1-1/8" steerer
<b>Rims</b>	Cannondale C3, double wall, alloy
<b>Hubs</b>	Formula FM-21 front, FM-22 rear
<b>Spokes</b>	Stainless, 15g
<b>Tires</b>	Kenda Kwick Trax, 700 x 38c
<b>Pedals</b>	FPD Resin w/Kraton Insert
<b>Crank</b>	Shimano M191, 48/38/28
<b>Bottom Bracket</b>	Tange cartridge type
<b>Chain</b>	KMC 8-speed
<b>Rear Cogs</b>	Sunrace CSM668, 11-32
<b>Front Derailleur</b>	Shimano M-191
<b>Rear Derailleur</b>	Shimano Acera
<b>Shifters</b>	Shimano Revo Twist Type, 8-speed
<b>Handlebar</b>	Women's Cannondale C4, 50 mm rise, alloy
<b>Stem</b>	Tranz X Comfort Grip, Tool-free Adjustment, quill type
<b>Headset</b>	Semi-integrated cartridge, threaded
<b>Brakes</b>	Cannondale V Brake w/modulator
<b>Brake Levers</b>	Cannondale, 4 finger w/Kraton comfort insert
<b>Saddle</b>	Women's Cannondale Ultra Comfort
<b>Seatpost</b>	Cannondale Suspension, 40 mm travel
<b>Sizes</b>	S, T
<b>Color 1 (code)</b>	Jet Black (gloss) (BLK).
<b>Color 2 (code)</b>	Pearl White (gloss) (WHT).
<b>Extras</b>	Cannondale Ergo Lock-On grips, Tranz X Comfort Grip quick release skewers and quick release seat binder

**ADVENTURE 3 26"**

<b>Code</b>	1CSW3
<b>Frame</b>	Adventure Women's step-thru, double butted 6061 alloy, for 26" wheels
<b>Fork</b>	RST Sofi T 26", 50 mm, 1-1/8" steerer
<b>Rims</b>	Cannondale C3, double wall, alloy, 26"
<b>Hubs</b>	Formula FM-21 front, FM-22 rear
<b>Spokes</b>	Stainless, 15g
<b>Tires</b>	Kenda NPJ signature, 26 x 1.25"
<b>Pedals</b>	FPD Resin w/Kraton Insert
<b>Crank</b>	Shimano M191, 48/38/28
<b>Bottom Bracket</b>	Tange cartridge type
<b>Chain</b>	KMC 8-speed
<b>Rear Cogs</b>	Sunrace CSM668, 11-32
<b>Front Derailleur</b>	Shimano M-191
<b>Rear Derailleur</b>	Shimano Acera
<b>Shifters</b>	Shimano Revo Twist Type, 8-speed
<b>Handlebar</b>	Women's Cannondale C4, 50 mm rise, alloy
<b>Stem</b>	Tranz X Comfort Grip, Tool-free Adjustment, quill type
<b>Headset</b>	Semi-integrated cartridge, threaded
<b>Brakes</b>	Cannondale V Brake w/modulator
<b>Brake Levers</b>	Cannondale, 4 finger w/Kraton comfort insert
<b>Saddle</b>	Women's Cannondale Ultra Comfort
<b>Seatpost</b>	Cannondale Suspension, 40 mm travel
<b>Sizes</b>	S, T
<b>Color 1 (code)</b>	Jet Black (gloss) (BLK).
<b>Color 2 (code)</b>	Pearl White (gloss) (WHT).
<b>Extras</b>	Cannondale Ergo Lock-On grips, Tranz X Comfort Grip quick release skewers and quick release seat binder





# WOMEN'S FULL SUSPENSION GEOMETRY

		SCARLET		
SPECIFICATIONS		PETITE	SMALL	MEDIUM
A	Seat Tube Length (cm/in)	40.7/16.0	43.2/17.0	45.7/18.0
B	Top Tube Horizontal (cm/in)	54.0/21.3	55.6/21.9	57.2/22.5
C	Top Tube Actual (cm/in)	52.1/20.5	53.4/21.0	54.9/21.6
D	Head Tube Angle	67.6°	67.7°	67.8°
E	Seat Tube Angle Effective	73.7°	73.6°	★
F	Standover (cm/in)	71.8/28.3	72.4/28.5	73.0/28.7
G	Head Tube Length (cm/in)	13.4/5.3	★	★
H	Wheelbase (cm/in)	108.6/42.8	110.0/43.3	113.1/44.5
I	Front Center (cm/in)	65.8/25.9	67.2/26.5	70.3/27.7
J	Chain Stay Length (cm/in)	42.8/16.9	★	★
K	Bottom Bracket Drop (cm/in)	1.2/0.5	★	★
L	Bottom Bracket Height (cm/in)	35.0/13.8	★	★
M	Fork Rake (cm/in)	4.0/1.6	★	★
N	Trail (cm/in)	9.6/3.8	9.5/3.8	9.5/3.8

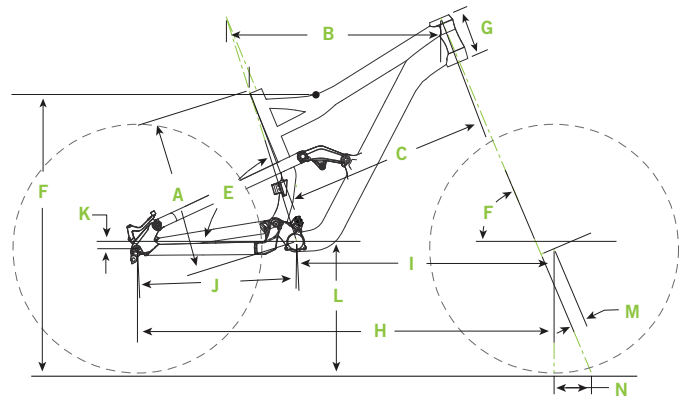

		LEXI		
SPECIFICATIONS		PETITE	SMALL	MEDIUM
A	Seat Tube Length (cm/in)	40.6/16.0	43.2/17.0	45.7/18.0
B	Top Tube Horizontal (cm/in)	53.0/20.9	56.0/22.0	57.5/22.6
C	Top Tube Actual (cm/in)	50.8/20.0	53.5/21.1	55.0/21.7
D	Head Tube Angle	68.5°	69.0°	69.0°
E	Seat Tube Angle Effective	73.5°	★	★
F	Standover (cm/in)	72.9/28.7	73.1/28.8	75.9/29.9
G	Head Tube Length - (cm/in)	13.4/5.3	★	★
H	Wheelbase (cm/in)	105.2/41.4	107.6/42.4	109.1/43.0
I	Front Center (cm/in)	62.8/24.7	65.2/25.7	66.6/26.2
J	Chain Stay Length (cm/in)	42.5/16.7	★	★
K	Bottom Bracket Drop (cm/in)	0.0/0.0	★	★
L	Bottom Bracket Height (cm/in)	33.0/13.0	★	★
M	Fork Rake (cm/in)	4.5/1.8	★	★
N	Trail (cm/in)	8.2/3.2	7.8/3.1	7.8/3.1

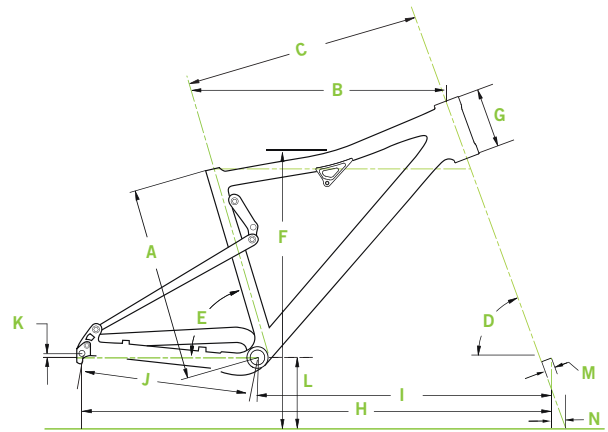

# WOMEN'S HARDTAIL GEOMETRY

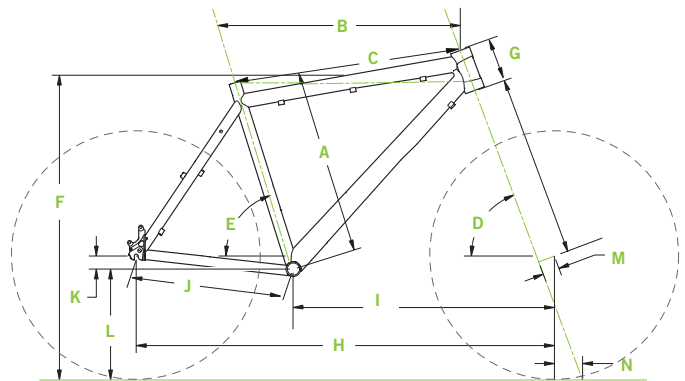

		FLASH WOMEN'S				TRAIL SL WOMEN'S				TRAIL WOMEN'S			
SPECIFICATIONS		PETITE	SMALL	MEDIUM	TALL	PETITE	SMALL	MEDIUM	TALL	PETITE	SMALL	MEDIUM	TALL
A	Seat Tube Length (cm/in)	35.0/13.8	38.0/15	41.5/16.3	45.0/17.7	35.0/13.8	38.0/15	41.5/16.3	45.0/17.7	35.0/13.8	38.0/15	41.5/16.3	45.0/17.7
B	Top Tube Horizontal (cm/in)	52.5/20.7	55.0/21.7	57.0/22.4	59.0/23.2	52.0/20.5	55.0/21.7	57.5/22.6	58.9/23.2	52.1/20.5	55.1/21.7	57.1/22.5	58.9/23.2
C	Top Tube Actual (cm/in)	52.9/20.8	53.8/21.2	55.1/21.7	56.7/22.3	52.8/20.8	53.9/21.2	55.6/21.9	56.7/22.3	52.6/20.7	53.8/21.2	55.3/21.8	56.7/22.3
D	Head Tube Angle	70.0°	★	★	★	70.0°	★	★	★	70.0°	★	★	★
E	Seat Tube Angle Effective	75.0°	73.5°	★	★	75.0°	★	★	★	75.0°	73.5°	★	★
F	Standover (cm/in)	73.1/28.8	74.4/29.3	76.1/30	77.8/30.6	72.9/28.7	74.3/29.3	76.0/29.9	77.7/30.6	72.4/28.5	73.8/29.1	76.0/29.9	77.9/30.7
G	Head Tube Length (cm/in)	13.4/5.3	★	★	★	11.4/4.5	★	★	★	10.5/4.1	★	★	11.5/4.5
H	Wheelbase (cm/in)	103.8/40.9	104.9/41.3	106.9/42.1	108.9/42.9	103.4/40.7	104.7/41.2	107.3/42.2	108.7/42.8	103.4/40.7	104.7/41.2	106.9/42.1	108.7/42.8
I	Front Center (cm/in)	61.6/24.3	62.7/24.7	64.7/25.5	66.7/26.3	61.3/24.1	62.6/24.6	65.1/25.6	66.5/26.2	61.3/24.1	62.6/24.6	64.7/25.5	66.5/26.2
J	Chain Stay Length (cm/in)	42.4/16.7	★	★	★	42.4/16.7	★	★	★	42.4/16.7	★	★	★
K	Bottom Bracket Drop (cm/in)	3.0/1.2	★	★	★	3.5/1.4	★	★	★	3.5/1.4	★	★	★
L	Bottom Bracket Height (cm/in)	29.5/11.6	★	★	★	29.0/11.4	★	★	★	29.0/11.4	★	★	★
M	Fork Rake (cm/in)	4.5/1.8	★	★	★	4.5/1.8	★	★	★	4.5/1.8	★	★	★
N	Trail (cm/in)	7.0/2.8	★	★	★	7.0/2.8	★	★	★	7.0/2.8	★	★	★

★ Indicates same as previous

# WOMEN'S ROAD GEOMETRY

## SUPERSIX WOMEN'S CAAD10 WOMEN'S

SPECIFICATIONS	44	48	51	54
A Horizontal Top Tube Length (cm)	50.5	51.5	52.0	53.5
B Measured Size (cm)*	42	46	49	52
C Seat Tube Angle (degrees)	76	74.5	74.5	73.5
D Head Tube Angle (degrees)	70.5	72	72.5	73
E Chain Stay Length (cm)	40.5	★	★	★
F Fork Rake (cm)	4.5	★	★	★
G Bottom Bracket Height (cm)	26.5	26.5	26.5	26.8
H Wheelbase (cm)	96.3	95.9	96.1	96.3
I Trail (cm)	7.2	6.2	5.9	5.6
J Standover at Top Tube Midpoint (cm)	71.3	74	76.3	78.9
K Bottom Bracket Drop (cm)	7.2	★	★	★
L Front Center Distance (cm)	57	56.5	56.7	56.9
M Head Tube Length (cm)	10.5	11	13	15
N Stack (cm)	50.5	51.5	53.5	55.6
O Reach (cm)	36.4	36.9	37.0	37.0

\* The measured size is from the center of the bottom bracket to the top of the top tube, measured along the seat tube axis.  
All sizes have a slightly sloping top tube.

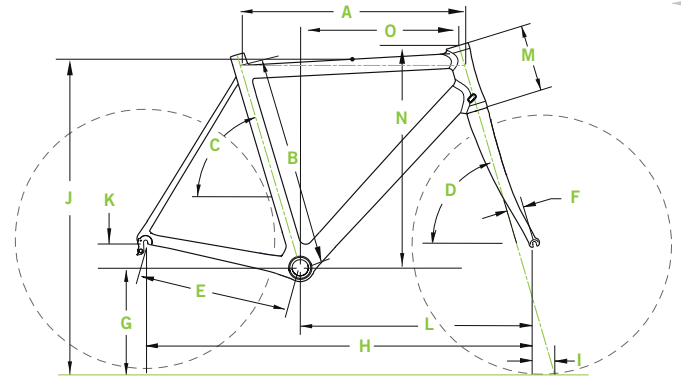

## SLICE WOMEN'S

## SYNAPSE CARBON WOMEN'S

## SYNAPSE ALLOY WOMEN'S

SPECIFICATIONS	47	51	54	44	48	51	54	44	48	51	54
Wheel Size	650c	700c	700c	700c	★	★	★	700c	★	★	★
A Horizontal Top Tube Length (cm)	49.5	50.5	53.5	50	51	52.5	53.5	50	51	52	53
B Measured Size (cm)	46	50	51.5	38	42	45	49	40	44	47	50
C Seat Tube Angle (degrees)*	variable	variable	variable	76	74.5	74	74	76	76	74	74
D Head Tube Angle (degrees)	71	71.5	71.5	70.5	71	72	72.5	70.5	70.5	72	72
E Chain Stay Length (cm)	37	40	40	41	★	★	★	41.5	★	★	★
F Fork Rake (cm)	4.0	4.5	4.5	5.0	★	★	★	5.0	★	★	★
G Bottom Bracket Height (cm)	26.5	★	★	26.5	★	★	★	26.5	★	★	★
H Wheelbase (cm)	92	95.4	98.5	97.2	97.0	97.5	98.2	97.7	97.9	98.0	99.3
I Trail (cm)	6.6	6.5	6.5	6.6	6.3	5.7	5.4	66.3	66.3	56.9	56.9
J Standover at Top Tube Midpoint (cm)	71.9	74.9	76.4	69.8	72.1	74.4	77.0	71.6	73.2	75.6	77.0
K Bottom Bracket Drop (cm)	5	7.2	7.2	7.2	★	★	★	72.0	72.0	72.0	69.0
L Front Center Distance (cm)	55.6	56.5	59.6	57.3	57.1	57.6	58.3	57.3	57.5	57.6	58.8
M Head Tube Length (cm)	10.3	9	10.5	12.5	13	14.5	16	13	13	14.5	16
N Stack (cm)	47.8	49.4	50.9	52.4	53.0	54.8	56.4	52.9	52.9	54.8	54.5
O Reach (cm)	36.5	37.1	39.8	35.3	35.5	36.3	37.1	35.4	36.8	36.4	37.6

\* The Slice seat post has two positions for mounting the saddle. A full range of angles from 73 to 78 degrees is achievable depending on the rider's preference and/or the event.

\* The measured size is from the center of the bottom bracket to the top of the top tube, measured along the seat tube axis.

★ Indicates same as previous

## ⚠ WARNINGS!

Bicycling has risks of serious injury or death that cannot be completely avoided. Risk can be minimized by: Reading and following all warnings and instructions in owner's manuals, owner's manual supplements, always wearing a helmet, practice and step-by-step learning, riding in control and within your capabilities.

Catalog text and descriptions are marketing materials, not instructions or guidelines for use!

Visit <http://www.cannondale.com/bikes/tech/safety> for warnings, technical documents, and safety guidelines.

**Warning:** Reflectors are not a substitute for proper lights. It is your responsibility to equip your bicycle with all state and locally mandated lights. Riding at dawn, at dusk, at night or at other times of poor visibility without a bicycle lighting system which meets local and state laws and without reflectors is dangerous and may result in serious injury or death.

If you ride your bike before dawn or after dusk, your bicycle must be equipped with lights so that you can see the road and avoid road hazards, and so that others can see you. Traffic laws treat

bicycles like any other vehicle. That means you must have a white front and a red rear light operating if you are riding after dusk. Your bike dealer can recommend a battery or generator powered lighting system appropriate to your needs.

Cannondale also strongly urges you to use a flashing light or strobe. All of us at Cannondale who ride at night or in conditions of lower visibility use flashers. They can save your life

**Please note:** Despite our nagging, members of the Liquigas pro road racing team (and other professional sponsored teams) may appear or race without helmets. We don't think it's a good idea, but they are experienced, professional cyclists and they know the risks. They are also adults, so we respect their right to choose. Despite the intransigence of any teams, we strongly advocate the use of helmets on every ride. Wearing a helmet is perhaps your single best defense against a major medical catastrophe while riding, so buckle up!

**Warning: Free riding is inherently dangerous. Read Free ride Warning at <http://www.cannondale.com/bikes/tech/safety.html>**

# WOMEN'S RECREATION GEOMETRY

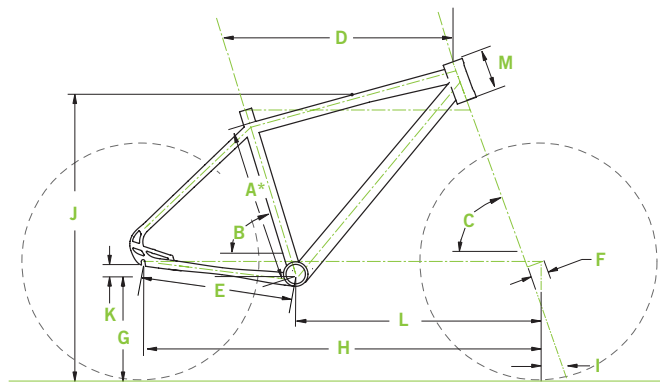

SPECIFICATIONS	QUICK CARBON WOMEN'S		QUICK SL WOMEN'S			
	SMALL	TALL	XS/26"	PETITE	SMALL	TALL
Wheel Size	700c	700c	26"	700c	700c	700c
<b>A*</b> Measured Size (cm/in)*	38.5/15.2	43.5/17.1	32.0/12.6	33.0/12.9	38.5/15.2	43.5/17.1
<b>B</b> Seat Tube Angle (degrees)	75	74	76	75	75	74.5
<b>C</b> Head Tube Angle (degrees)	71	71.5	70.5	71	70.5	71.5
<b>D</b> Horizontal Top Tube Length (cm)	53.5	56	50.5	53.5	53.5	55
<b>E</b> Chain Stay Length (cm)	43	★	43.5	★	★	★
<b>F</b> Fork Rake (cm)	5.0	★	5.0	★	★	★
<b>G</b> Bottom Bracket Height (cm)	27.4	27.4	27.4	★	★	★
<b>H</b> Wheelbase (cm)	101.4	103.9	100.5	101.8	102.4	103.3
<b>I</b> Trail (cm)	6.6	5.9	6.2	6.6	6.9	6.2
<b>J</b> Standover Height (cm)	74.3	78.3	68.9	70.8	74.5	78.5
<b>K</b> Bottom Bracket Drop (cm)	7.0	★	5.1	7.0	★	★
<b>L</b> Front Center (cm)	59.5	60.8	57.5	59.2	60	62.2
<b>M</b> Head Tube Length (cm)	14	17	14	12.5	14	18

\*Measured size is from the center of the bottom bracket to the top of the top tube, measured along the seat tube axis.

SPECIFICATIONS	ADVENTURE WOMEN'S		ADVENTURE 26" WOMEN'S	
	SMALL	TALL	SMALL	TALL
<b>A*</b> Seat Tube Length Overall (cm/in)	36.8/14.5	45.7/18.0	36.8/14.5	45.7/18.0
<b>B</b> Seat Tube Angle (degrees)	70	★	70	★
<b>C</b> Head Tube Angle (degrees)	69	★	69	★
<b>D</b> Horizontal Top Tube Length (cm)	55.5	56.5	54	55.5
<b>E</b> Chain Stay Length (cm)	46.5	★	45.7	★
<b>F</b> Fork Rake (cm)	4.5	★	4.5	★
<b>G</b> Bottom Bracket Height (cm)	28.0	★	30.3	★
<b>H</b> Wheelbase (cm)	104.4	105.6	103.3	104.9
<b>I</b> Trail (cm)	8.5	★	8.5	★
<b>J</b> Standover Height (cm)	59.3	★	53.7	★
<b>K</b> Bottom Bracket Drop (cm)	6.8	★	4.5	★
<b>L</b> Front Center (cm)	58.8	60.0	58.0	59.6
<b>M</b> Head Tube Length (cm)	13.6	15.6	13.6	15.6

★ Indicates same as previous

## REGISTERED TRADEMARKS © OF THE CYCLING SPORTS GROUP, INC.:

Cannondale, the Cannondale "C" logo, Daytripper, Feel It, Fatty, Gemini, Jekyll, Lefty, Optimo, Perp, Prophet, Scalpel, Slice, Synapse, SystemSix, Hooligan.

## TRADEMARKS ™ OF THE CYCLING SPORTS GROUP, INC.:

BB30, CAAD (Cannondale Advanced Aluminum Design), Caffeine, Capo, Chase, CO2, HeadShok, Hi-MOD, Hollowgram, Judge, Just for Women, Moto, PowerPyramid, Quick, Q-Lab, Rize, RZ, Rush, S.A.V.E., Si, SuperSix, System Integration, Taurine, The Cut. BallisTec Carbon, SmartFormed Alloy, ECS-TC (Enhanced Center-Stiffness, Torsion Control) System, Zero Pivot, Lexi, Scarlet, Felicity, Cannondale Factory Racing.

Liquigas-Doimo, FSA, Mavic, Campagnolo, SRM, Speedplay, Schwalbe, Elite, Sci Con CFR: fi'zi-k, RockShox, SRAM, MET, crankbrothers, Avid, Cannondale - Cyclocrossworld.com: Zipp, Prologo, crankbrothers, TRP, Control Tech are sponsorship partners and their trademarks are used with their permission. FOX and FOX RLC are trademarks of FOX Factory Inc. and are used with their permission. Solo Air, RockShox, XLoc and PopTop are trademarks of SRAM and are used with their permission. X-12 is a trademark of Syntace GmbH and is used with their permission. EVO is a trademark of Aprebic Industry Co. Ltd. and used under license.

## WWW.CANNONDALE.COM

Please visit [cannondale.com](http://cannondale.com) to learn more about Cannondale and the 2011 bikes! Specifications subject to change without notice.

Please refer to [www.cannondale.com](http://www.cannondale.com) for the most recent specifications.

## NO WEIGHTS?

Don't believe the hype. Scales differ, and marketing departments have been known to fib. The best way to compare bike weights is to head to your local bike shop. Grab two comparably spec'd and built bikes, and ask the proprietor for a scale. Hang 'em high, and see who's the lightest.

## SPECIAL THANKS GOES TO:

- Ale Di Lullo Photography
- Adam Campbell Photography
- Adam Coppola Photography
- Brian Hodes/Velo Images
- Chris Milliman Photography
- Dan Barham Photography
- Ego promotion/Maaswerd and Kuestenbrueck
- Eric Wynn Photography
- John Segesta/Wahoomedia
- Mike Karcher/Wix Pix
- Navone Studios
- Roberto Bettini Photo
- Sincere Photo and Design
- Tarsey Anastos-Navone Studios
- DH Productions
- Juan Vivo
- Kirsten Begg-Swider
- The Canyons Resort
- Our riders
- Our vendors
- Our dealers
- And you for riding a Cannondale

