



2012
BICYCLES

cannondale



INTRO

WELCOME TO THE TEAM.

We are extremely proud to have the most innovative athletes as part of the Cannondale team: the precise Liquigas-Cannondale squad, the vivacious Cannondale Factory Racing team, and the mind-bending OverMountain crew. The team also includes record-breaking triathletes and Cyclocross legends. These athletes set the standard, breaking boundaries, leading never following.

But these athletes just scratch the surface of the Cannondale team. There are regional teams, your local shop team and the gang you meet for early morning rides. Few of them truly get acknowledged. But they all understand the value of ride quality and practical engineering. They are our motivation, our compass.

You may not know it, but your team is big, bigger than you think: Ivan Basso climbs the Pyrenees for you. Chrissie Wellington breaks records for you. Tinker Juarez rides every year for you. Tim Johnson slogs through the winter mud for you. Aaron Chase and Mark Weir set trends for you. In addition you have an army of passionate designers, engineers and product managers who are also on your team. None of them settle in the constant pursuit of perfection.

When you pick up a Cannondale bike, the technologies we develop like BallisTec carbon, SAVE micro suspension, Lefty, DYAD RT2, Zero Pivot or BB30 are designed exclusively for you. Whether you cross the finish line on a SuperSix EVO, watch the sun set through the trees on a Scalpel 29'er or take a Bad Girl to the art gallery opening, you will experience the same feeling.

This is what we call the Perfect Ride.



CONTENTS



ROAD

ELITE ROAD		PERFORMANCE ROAD		TRIATHLON / TIME TRIAL		CYCLOCROSS	
SUPERSIX EVO	6-9	SYNAPSE	20-25	SLICE	26-27	SUPERX	28-29
SUPERSIX	10-13					CAADX	30-31
CAAD10	14-17						
CAAD8	18-19						

MOUNTAIN

OVERMOUNTAIN		FULL SUSPENSION		HARDTAIL		29'ER	
CLAYMORE	34-37	LEFTY HEADSHOK	42-45	FLASH	52	SCALPEL 29'ER	56-59
JEKYLL	38-41	RZ ONE TWENTY	46-47	TRAIL	53-55	FLASH 29'ER	60-65
		SCALPEL	48-51			TRAIL 29'ER	66-69

RECREATION / URBAN

BAD BOY	72-75	ADVENTURE	82-83
QUICK CARBON / QUICK SL / QUICK	76-79	ROAD TANDEM	84
QUICK CX	80-81	HOOLIGAN	85

SPECIFICATIONS

SPECIFICATIONS		GEOMETRY	
ROAD	88-91	ROAD	97-98
MOUNTAIN	91-94	MOUNTAIN	99-101
RECREATION / URBAN	95	RECREATION / URBAN	102-103

FLIP THE CATALOG FOR OUR AMAZING WOMEN'S BIKES.



ROAD

ELITE ROAD

SUPERSIX EVO	6-9
SUPERSIX	10-13
CAAD10	14-17
CAAD8	18-19

PERFORMANCE ROAD

SYNAPSE	20-25
---------	-------

TRIATHLON / TIME TRIAL

SLICE	26-27
-------	-------

CYCLOCROSS

SUPERX	28-29
CAADX	30-31



SUPERSIX EVO

> SUPER. EVOLVED.

695 GRAMS AND 142.3 NM/DEG/KG.*

BEING THE LIGHTEST IN THE WORLD, WITH THE BEST STIFFNESS-TO-WEIGHT IS IMPRESSIVE. BUT THE TRUE BEAUTY OF EVO IS ITS BALANCE OF LIGHT WITH STRONG, AND STIFF WITH SMOOTH. EVOLVE.



*ZEDLER FAHRRADTECHNIK, 4/11, 56 CM, ULTIMATE FRAME, NORMALIZED TO TOUR MAGAZINE TEST STANDARDS.

ROAD
MOUNTAIN
RECREATION/URBAN
WOMEN'S
SPECIFICATIONS



> LIGHT, STIFF AND STRONG

Our leading edge carbon construction utilizes our **BallisTec** Carbon Technology to create the lightest production road frame ever made, with the best stiffness-to-weight ever measured, with the strength to outperform even most aluminum frames.

> SPEED SAVE VERTICAL COMPLIANCE

Similar to the suspension on an F1 car, the **SPEED SAVE** vertical compliance features are engineered to help the bike roll faster. Subtle flex zones in the rear stays, fork and seat tube improve rolling speed, acceleration, cornering speed and control without negatively affecting power transfer.

> DRAG REDUCTION

The EVO achieves its incredible stiffness and strength with smaller diameter tubes than the competition. This dramatically reduces the EVO's frontal area and reduces drag without the added weight and compromises of aero shaped tubes.

2RSEUD SUPERSIX EVO ULTIMATE

EXPOSED CARBON W/OUTLINE DECALS (MATTE) (ULT)

FRAME	SUPERSIX EVO, BALLISTEC HI-MOD CARBON, SPEED SAVE
FORK	BALLISTEC HI-MOD FULL CARBON, SPEED SAVE
WHEELS	DT SWISS, RRC425F FRONT, RRC525R REAR, CARBON TUBULARS

TIRES	SCHWALBE ULTREMO TUBULAR LIGHT, 700X23C
CRANKS	HOLLOWGRAM SL, BB30, SI RINGS, 53/39 *
DERAILLEURS	SRAM RED

SHIFTERS	SRAM RED
BRAKES	TRP 970SL
SIZES	48, 50, 52, 54, 56, 58, 60, 63CM

*(50/34 RINGS AND SPIDER INCLUDED)



2RSE0D
SUPERSIX EVO TEAM

LIQUIGAS TEAM REPLICA (GLOSS) (LIQ.)

FRAME	SUPERSIX EVO, BALLISTEC HI-MOD CARBON, SPEED SAVE	TIRES	MAVIC YKSION, GRIPLINK FRONT AND POWERLINK REAR, 700X23C	SHIFTERS	SRAM RED
FORK	SUPERSIX EVO, BALLISTEC HI-MOD FULL CARBON, SPEED SAVE	CRANKS	HOLLOWGRAM SL, BB30, SRAM RED RINGS, 53/39*	BRAKES	SRAM RED
WHEELS	MAVIC COSMIC CARBONE SLR	DERAILLEURS	SRAM RED	SIZES	48, 50, 52, 54, 56, 58, 60, 63CM

*50/34 RINGS AND SPIDER INCLUDED



2RSE1D
SUPERSIX EVO 1 DURA ACE

MAGNESIUM WHITE W/ JET BLACK (GLOSS) (WHT.)

FRAME	SUPERSIX EVO, BALLISTEC HI-MOD CARBON, SPEED SAVE	TIRES	SCHWALBE ULTREMO ZX, 700X23C	SHIFTERS	SHIMANO DURA-ACE 7900
FORK	SUPERSIX EVO, BALLISTEC HI-MOD FULL CARBON, SPEED SAVE	CRANKS	HOLLOWGRAM SL, BB30, FSA DA79 RINGS, 53/39*	BRAKES	SHIMANO DURA-ACE 7900
WHEELS	MAVIC KSYRIUM SL	DERAILLEURS	SHIMANO DURA-ACE 7900	SIZES	48, 50, 52, 54, 56, 58, 60, 63CM

*50/34 RINGS AND SPIDER INCLUDED



2RSE1D
SUPERSIX EVO DI2

EXPOSED CARBON W/ CHARCOAL GREY, WHITE, RED (MATTE) (CRB.)

FRAME	SUPERSIX EVO, BALLISTEC HI-MOD CARBON, SPEED SAVE	TIRES	MAVIC YKSION, GRIPLINK FRONT AND POWERLINK REAR, 700X23C	SHIFTERS	SHIMANO DURA-ACE DI2
FORK	SUPERSIX EVO, BALLISTEC HI-MOD FULL CARBON, SPEED SAVE	CRANKS	HOLLOWGRAM SL, BB30, FSA DA79 RINGS, 53/39*	BRAKES	SHIMANO DURA-ACE 7900
WHEELS	MAVIC KSYRIUM SLR	DERAILLEURS	SHIMANO DURA-ACE DI2	SIZES	48, 50, 52, 54, 56, 58, 60, 63CM

*50/34 RINGS AND SPIDER INCLUDED



2RSE2D, 2RSE2C
SUPERSIX EVO 2 SRAM RED

EXPOSED CARBON W/ WHITE, GREEN (GLOSS) (BLK.)

MAGNESIUM WHITE W/ JET BLACK (GLOSS) (WHT.)

FRAME	SUPERSIX EVO, BALLISTEC HI-MOD CARBON, SPEED SAVE	TIRES	SCHWALBE ULTREMO ZX, 700X23C	SHIFTERS	SRAM RED
FORK	SUPERSIX EVO, BALLISTEC HI-MOD FULL CARBON, SPEED SAVE	CRANKS	SRAM RED W/CANNONDALE GRAPHICS, BB30, 50/34 COMPACT	BRAKES	SRAM RED
WHEELS	MAVIC KSYRIUM ELITE	DERAILLEURS	SRAM RED	SIZES	48, 50, 52, 54, 56, 58, 60, 63CM



OPTION: 53/39



SUPERSIX
 > SPEED. RACER.

SUPER, DEFINED. WITH TWO GRAND TOUR VICTORIES IN A SINGLE SEASON, THE SUPERSIX HAS WINNING IN ITS BLOOD. GET USED TO WINNING.

ROAD
 MOUNTAIN
 RECREATION/URBAN
 WOMEN'S
 SPECIFICATIONS

VICTORIES & AWARDS



2RSSID
 SUPERSIX ULTEGRA DI2

JET BLACK W/ MAGNESIUM WHITE AND CHARCOAL GREY (MATTE) (BB0).

FRAME	SUPERSIX, FULL CARBON, DI2 SPECIFIC
FORK	SUPERSIX, FULL CARBON
WHEELS	MAVIC KSYRIUM ELITE

TIRES	SCHWALBE DURANO S, 700X23C, FOLDING
CRANKS	FSA SL-K LIGHT CARBON BB30, 50/34
DERAILLEURS	SHIMANO ULTEGRA DI2

SHIFTERS	SHIMANO ULTEGRA DI2
BRAKES	SHIMANO ULTEGRA 6700
SIZES	48, 50, 52, 54, 56, 58, 60, 63CM

IVAN BASSO.

LIQUIGAS-CANNONDALE
 PRO RIDER, WINNER
 2010 GIRO D'ITALIA.

"IT IS INCREDIBLE. IT'S SO LIGHT AND STIFF, BUT IS COMFORTABLE AS WELL, PERFECTLY BALANCED."

> RACE-WINNING PEDIGREE

Light and stiff, with an alive, communicative ride-feel, the 2012 SuperSix is the direct descendant of the frame that carried Team Liquigas-Cannondale to victory in the Giro d'Italia and Vuelta a España.

> OVERSIZED FOR POWER TRANSFER

The massively oversized **BeatBox** BB area, 1-1/8" to 1.5" tapered steerer, deep-radius headtube and oversized asymmetric chainstays, deliver point-and-shoot handling, incredible stiffness and maximum power transfer.

> HOURGLASS SEAT STAYS

Curved, hourglass-shaped seat stays allow for vertical deflection and compliance over less than perfect road surfaces. The result is improved control and comfort after long days in the saddle.



OPTION: 53/39



2RSS3D, 2RSS3C

SUPERSIX 3 ULTEGRA

MAGNESIUM WHITE (GLOSS) (WHT).

RACE RED (GLOSS) (RED).

FRAME	SUPERSIX, FULL CARBON	TIRES	SCHWALBE DURANO S, 700X23C, FOLDING	SHIFTERS	SHIMANO ULTEGRA 6700
FORK	SUPERSIX, FULL CARBON	CRANKS	FSA SL-K LIGHT CARBON BB30, 50/34 COMPACT	BRAKES	SHIMANO ULTEGRA 6700
WHEELS	MAVIC KSYRIUM EQUIPE	DERAILLEURS	SHIMANO ULTEGRA 6700	SIZES	48, 50, 52, 54, 56, 58, 60, 63CM



OPTION: 53/39



2RSS5D, 2RSS5C

SUPERSIX 5 105

LIQUIGAS TEAM REPLICA (GLOSS) (REP).

MAGNESIUM WHITE (GLOSS) (WHT).

FRAME	SUPERSIX, FULL CARBON	TIRES	SCHWALBE LUGANO, 700X23C, FOLDING	SHIFTERS	SHIMANO 105 5700
FORK	SUPERSIX, FULL CARBON	CRANKS	FSA GOSSAMER PRO BB30, 50/34 COMPACT	BRAKES	TEKTRO R580
WHEELS	SHIMANO RS10	DERAILLEURS	SHIMANO 105 5700	SIZES	48, 50, 52, 54, 56, 58, 60, 63CM



OPTION: 53/39



2RSS4D, 2RSS4C

SUPERSIX 4 RIVAL

CANNONDALE YELLOW (GLOSS) (YEL).

JET BLACK W/ MAGNESIUM WHITE (MATTE) (BBQ).

FRAME	SUPERSIX, FULL CARBON	TIRES	MAVIC AKSION, 700X23C, FOLDING	SHIFTERS	SRAM RIVAL
FORK	SUPERSIX, FULL CARBON	CRANKS	SRAM S500, BB30, 50/34 COMPACT	BRAKES	SRAM DUAL PIVOT
WHEELS	MAVIC AKSIUM WTS	DERAILLEURS	SRAM RIVAL	SIZES	48, 50, 52, 54, 56, 58, 60, 63CM

2RSS6C

SUPERSIX 6 APEX

JET BLACK (MATTE) (BBQ).

FRAME	SUPERSIX, FULL CARBON	TIRES	SCHWALBE LUGANO, 700X23C, FOLDING	SHIFTERS	SRAM APEX
FORK	SUPERSIX, FULL CARBON	CRANKS	FSA OMEGA BB30, 50/34	BRAKES	SRAM APEX
WHEELS	SHIMANO RS01A	DERAILLEURS	SRAM APEX WIFLI	SIZES	48, 50, 52, 54, 56, 58, 60, 63CM

CAAD10

X. FACTOR.

AT JUST 1150 GRAMS*, THE ULTRA-LIGHT CAAD10 HAS A MAGICAL BLEND OF STIFFNESS AND SMOOTHNESS THAT OUTPERFORMS MOST ELITE CARBON FRAMES. HIGH PERFORMANCE ALUMINUM IS BACK.

*SIZE 56, BLACK ANODIZED COLOR COMPLETE WITH HARDWARE

ROAD
MOUNTAIN
RECREATION/URBAN
WOMEN'S
SPECIFICATIONS

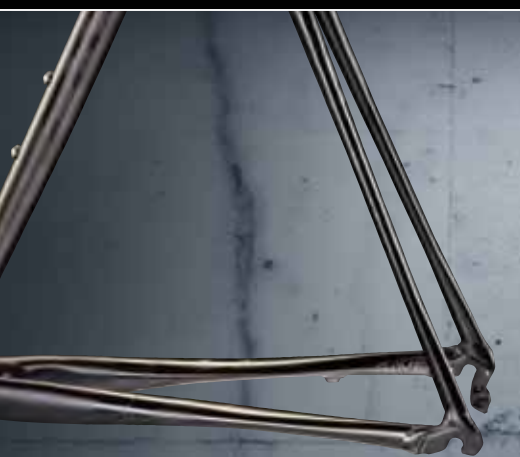

> SPEED SAVE ROLLS FASTER

SPEED SAVE features are engineered not simply to make the bike more comfortable but to help the bike roll faster. They deliver improved rolling speed, better acceleration and dramatically faster cornering. Engineered to win.

> TOP TUBE STIFFNESS FOR PRECISION

Steering response and stability are directly related to top tube stiffness. With a cross section of almost 20 cm² at the head tube, CAAD10's top tube is engineered to be stiff. Optimally shaped for increased knee clearance and precise handling. Pin-point steering response with rock solid stability.

> SPEED SAVE FORK

Our new **SPEED SAVE** fork achieves the elusive combination of increased fork angle for shock absorption without increasing the bike's wheelbase. The secret? The dropouts. With a subtle offset to the rear of the tapered carbon blades, the fork maintains its razor sharp handling, eliminating buzz and chatter.

2RAX1D, 2RAX1C

CAAD10 1 DURA-ACE

BLACK ANODIZED (MATTE) (BLA)



OPTION: 53/39

FRAME CAAD10, SMARTFORMED 6069 ALLOY, SPEED SAVE

FORK CAAD10, FULL CARBON, SPEED SAVE

WHEELS SHIMANO RS80

TIRES SCHWALBE DURANO S, 700X23C, FOLDING

CRANKS FSA SL-K LIGHT CARBON, BB30, COMPACT 50/34

DERAILLEURS SHIMANO DURA-ACE 7900

SHIFTERS SHIMANO DURA-ACE 7900

BRAKES SHIMANO ULTEGRA 6700

SIZES 48, 50, 52, 54, 56, 58, 60, 63CM



OPTION: 53/39



2RAX3D, 2RAX3C

CAAD10 3 ULTEGRA

MAGNESIUM WHITE (GLOSS) (WHT).

JET BLACK (GLOSS) (BLK).

FRAME	CAAD10, SMARTFORMED 6069 ALLOY, SPEED SAVE	TIRES	MAVIC AKSION, 700X23C, FOLDING	SHIFTERS	SHIMANO ULTEGRA 6700
FORK	CAAD10, FULL CARBON, SPEED SAVE	CRANKS	FSA SL-K LIGHT CARBON, BB30, COMPACT 50/34	BRAKES	SHIMANO ULTEGRA 6700
WHEELS	MAVIC AKSIUM WTS	DERAILLEURS	SHIMANO ULTEGRA 6700	SIZES	48, 50, 52, 54, 56, 58, 60, 63CM



OPTION: 53/39



2RAX5D, 2RAX5C

CAAD10 5 105

LIQUIGAS TEAM REPLICA (GLOSS) (REP).

JET BLACK (MATTE) (BBQ).

FRAME	CAAD10, SMARTFORMED 6069 ALLOY, SPEED SAVE	TIRES	SCHWALBE LUGANO, 700X23C, FOLDING	SHIFTERS	SHIMANO 105 5700
FORK	CAAD10, FULL CARBON, SPEED SAVE	CRANKS	FSA GOSSAMER PRO, BB30, COMPACT 50/34	BRAKES	TEKTRO R580
WHEELS	SHIMANO RS-10	DERAILLEURS	SHIMANO 105 5700	SIZES	48, 50, 52, 54, 56, 58, 60, 63CM



OPTION: 53/39



2RAX4D, 2RAX4C

CAAD10 4 RIVAL

40 BLUE W/ 40 ORANGE (GLOSS) (BLU).

BRUSH ALUMINUM (GLOSS) (RAW).

FRAME	CAAD10, SMARTFORMED 6069 ALLOY, SPEED SAVE	TIRES	SCHWALBE LUGANO, 700X23C, FOLDING	SHIFTERS	SRAM RIVAL
FORK	CAAD10, FULL CARBON, SPEED SAVE	CRANKS	SRAM S500 BB30, COMPACT 50/34	BRAKES	SRAM DUAL PIVOT
WHEELS	FULCRUM RACING 7	DERAILLEURS	SRAM RIVAL	SIZES	48, 50, 52, 54, 56, 58, 60, 63CM

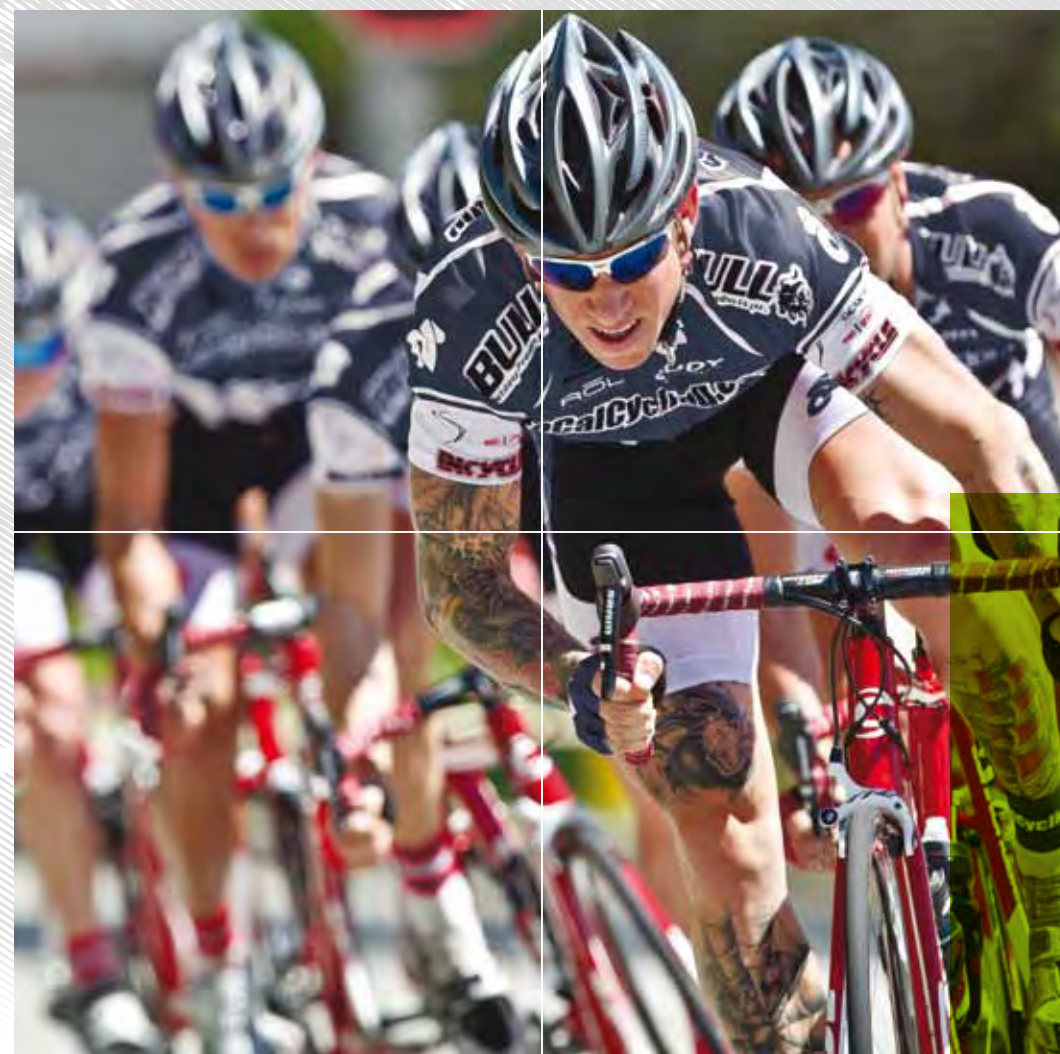

ROAD, USA, 03/11.
 "IT'S A FANTASTIC RIDE THAT CAN EASILY HANDLE EVEN THE TOUGHEST RIDES AND BE A SOLID, HIGH-PERFORMANCE, EVERYDAY WORKHORSE."

CAAD8

> LIGHT. SPEED.

ALWAYS GET A GOOD START. TOTALLY REDESIGNED FOR 2012 WITH FEATURES DRAWN FROM THE CAAD10 AND HEADS-UP RACE GEOMETRY, THE LIGHTEST-IN-CLASS CAAD8 BLOWS AWAY THE CONCEPT OF ENTRY LEVEL.



2RA85C

CAAD8 5 105

JET BLACK (GLOSS) (BLK)

NIAGRA BLUE (GLOSS) (BLU)

FRAME NEW CAAD8, OPTIMIZED 6061 ALLOY, SAVE

TIRES SCHWALBE LUGANO, 700X23C, FOLDING

SHIFTERS SHIMANO 105 5700

FORK CANNONDALE ULTRA, CARBON BLADES

CRANKS FSA GOSSAMER, BB30, 50/34

BRAKES TEKTRO R540, DUAL PIVOT, CARTRIDGE PAD

WHEELS MADDUX RS 3.0 SPEED, 32 HOLE

DERAILLEURS SHIMANO 105 5700

SIZES 48, 50, 52, 54, 56, 58, 60, 63CM

> CANNONDALE ALUMINUM EXPERTISE

Double-pass smooth welds, taper-butted tubes and the refined tube-shapes of the CAAD8 showcase our more than 20 years of aluminum frame-building experience.

> HEADS-UP RACE GEOMETRY

The CAAD8 shares the proven race geometry of its more expensive brethren but with a slightly taller headtube for a more relaxed riding position.

> CAAD10 DNA

CAAD8 shares many of the performance features, like the asymmetric chain stays, horizontally ovalized top tube, and SAVE vibration-reducing stays, of the ultra-high performance CAAD10.



2RA86C

CAAD8 6 TIAGRA

MAGNESIUM WHITE (GLOSS) (WHT)

JET BLACK (MATTE) (BBQ)

FRAME NEW CAAD8, OPTIMIZED 6061 ALLOY, SAVE

TIRES SCHWALBE LUGANO, 700X23C

SHIFTERS SHIMANO TIAGRA 4600

FORK CANNONDALE ULTRA, CARBON BLADES

CRANKS FSA OMEGA BB30, 50/34

BRAKES CANNONDALE C4, DUAL PIVOT, CARTRIDGE PAD

WHEELS MADDUX RS 3.0, 32 HOLE

DERAILLEURS SHIMANO TIAGRA 4600

SIZES 48, 51, 54, 56, 58, 61CM



2RA87C

CAAD8 7 SORA

JET BLACK (MATTE) (BBQ)

RACE RED (GLOSS) (RED)

FRAME NEW CAAD8, OPTIMIZED 6061 ALLOY, SAVE

TIRES SCHWALBE LUGANO, 700X23C

SHIFTERS SHIMANO SORA

FORK CANNONDALE ULTRA, CARBON BLADES

CRANKS FSA VERO, 50/34

BRAKES CANNONDALE C4, DUAL PIVOT, CARTRIDGE PAD

WHEELS MADDUX RS 3.0, 32 HOLE

DERAILLEURS SHIMANO SORA

SIZES 48, 51, 54, 56, 58, 61CM

SYNAPSE

FIRST CLASS.

PERFECT FOR LIQUIGAS-CANNONDALE ON THE COBBLES OF THE ARENBURG OR FOR EPIC GRAN FONDO RIDES, SYNAPSE IS THE PERFECT BLEND OF RACE-LEVEL PERFORMANCE AND ALL-DAY COMFORT. TAKE THE LONG WAY HOME.

VICTORIES & AWARDS



ROAD
MOUNTAIN
RECREATION/URBAN
WOMEN'S
SPECIFICATIONS

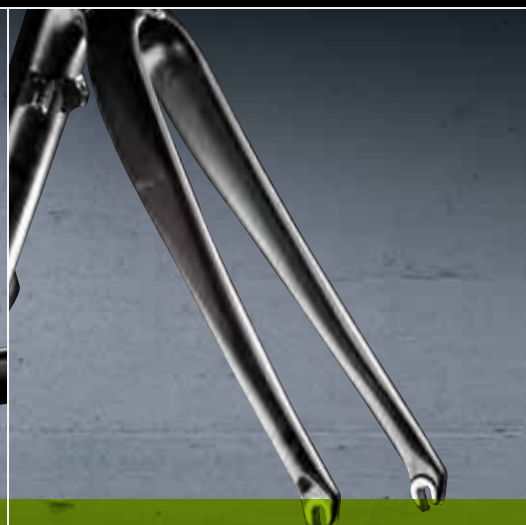
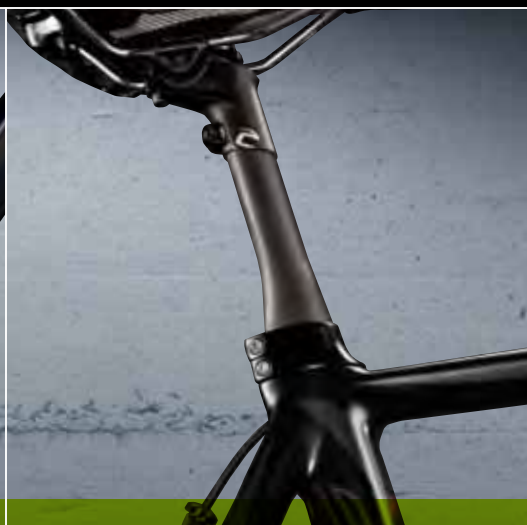
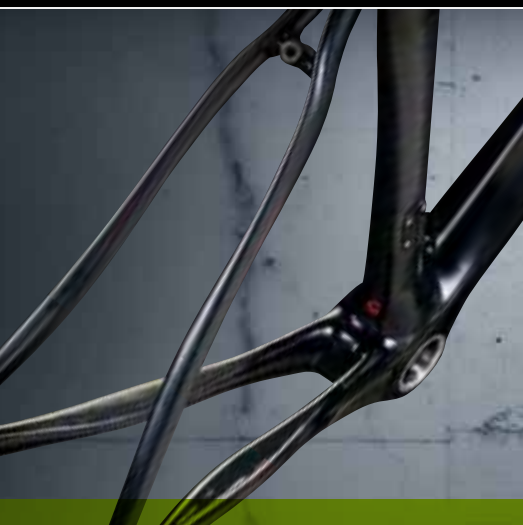

› SAVE PLUS FOR LONGER, MORE COMFORTABLE RIDES

SAVE PLUS is the newly redesigned micro suspension system made specifically for our Synapse line of bikes. With even more emphasis on comfort than SPEED SAVE, SAVE PLUS' rear stays feature a flattened area that can deflect vertically to absorb road buzz and shock while the increased width resists side-to-side and torsional flex.

› SAVE PLUS MULTIFLEX SEATPOST SYSTEM*

The new SAVE PLUS Multiflex Seatpost System features two different SAVE PLUS seatpost shafts, one with firm flex, and one with softer flex so riders can tune the ride-feel to their preference. Also compatible with 2009-2010 Synapse frames for owners who wish to upgrade.

*Second seatpost shaft offered after-market

› SAVE PLUS FORK SMOOTHS THE ROAD

The new SAVE PLUS fork is a gorgeously smooth-riding combination of sophisticated carbon lay-up and shaping, and offset dropouts for increased vertical deflection and vibration absorption with no loss in steering precision.

2RCL1C SYNAPSE HI-MOD 1 DURA-ACE

EXPOSED CARBON W/ CHARCOAL GREY (MATTE) (CRB).

FRAME	SYNAPSE, HI-MOD FULL CARBON, SAVE PLUS
FORK	SYNAPSE, HI-MOD FULL CARBON, SAVE PLUS
WHEELS	DT SWISS RR1450 TRICON

TIRES	SCHWALBE ULTREMO ZX, 700X25C
CRANKS	CANNONDALE HOLLOWGRAM SL BB30, 50/34, FSA DA-79 RINGS
DERAILLEURS	SHIMANO DURA-ACE 7900

SHIFTERS	SHIMANO DURA-ACE 7900
BRAKES	SHIMANO DURA-ACE 7900
SIZES	48, 51, 54, 56, 58, 61CM



2RCL2C
SYNAPSE HI-MOD 2 SRAM RED

MAGNESIUM WHITE (GLOSS) (WHT).

EXPOSED CARBON (MATTE) (CRB).

FRAME	SYNAPSE, HI-MOD FULL CARBON, SAVE PLUS	TIRES	SCHWALBE ULTREMO ZX, 700X25C	SHIFTERS	SRAM RED
FORK	SYNAPSE, HI-MOD FULL CARBON, SAVE PLUS	CRANKS	CANNONDALE SRAM RED, BB30, 50/34	BRAKES	SRAM RED
WHEELS	MAVIC KSYRIUM ELITE, BLACK	DERAILLEURS	SRAM RED	SIZES	48, 51, 54, 56, 58, 61CM



2RCS4C
SYNAPSE CARBON 4 RIVAL

EXPOSED CARBON (GLOSS) (BLU).

MAGNESIUM WHITE (GLOSS) (WHT).

FRAME	SYNAPSE, FULL CARBON, SAVE PLUS	TIRES	MAVIC AKSION, 700X25C, FOLDING	SHIFTERS	SRAM RIVAL
FORK	SYNAPSE, FULL CARBON, SAVE PLUS	CRANKS	SRAM S550, BB30, 50/34	BRAKES	SRAM DUAL PIVOT
WHEELS	MAVIC AKSIUM WTS	DERAILLEURS	SRAM RIVAL	SIZES	48, 51, 54, 56, 58, 61CM



2RCS3C
SYNAPSE CARBON 3 ULTEGRA

LIQUIGAS TEAM REPLICA (GLOSS) (REP).

EXPOSED CARBON (GLOSS) (BLK).

FRAME	SYNAPSE, FULL CARBON, SAVE PLUS	TIRES	SCHWALBE DURANO 700X25C, BLACK	SHIFTERS	SHIMANO ULTEGRA 6700
FORK	SYNAPSE, FULL CARBON, SAVE PLUS	CRANKS	FSA SL-K LIGHT CARBON, BB30, 50/34	BRAKES	SHIMANO ULTEGRA 6700
WHEELS	DT SWISS RR1600	DERAILLEURS	SHIMANO ULTEGRA 6700	SIZES	48, 51, 54, 56, 58, 61CM



2RCS5C
SYNAPSE CARBON 5 105

MAGNESIUM WHITE W/ RACE RED (GLOSS) (RED).

EXPOSED CARBON W/ MAGNESIUM WHITE (GLOSS) (BLK).

FRAME	SYNAPSE, FULL CARBON, SAVE PLUS	TIRES	SCHWALBE LUGANO, 700X25C, BLACK	SHIFTERS	SHIMANO 105 5700
FORK	SYNAPSE, FULL CARBON, SAVE PLUS	CRANKS	FSA GOSSAMER PRO BB30, 50/34	BRAKES	TEKTRO R580
WHEELS	SHIMANO RS10	DERAILLEURS	SHIMANO 105 5700	SIZES	48, 51, 54, 56, 58, 61CM



2RCS6C

SYNAPSE CARBON 6 APEX

EXPOSED CARBON (GLOSS) (BLU).

MAGNESIUM WHITE (GLOSS) (WHT).

FRAME	SYNAPSE, FULL CARBON, SAVE PLUS	TIRES	SCHWALBE LUGANO WIRE, 700X25C, BLACK	SHIFTERS	SRAM APEX
FORK	SYNAPSE, CARBON BLADES, SAVE	CRANKS	FSA OMEGA BB30, 50/34	BRAKES	SRAM APEX
WHEELS	SHIMANO RS01A	DERAILLEURS	SRAM APEX WIFLI	SIZES	48, 51, 54, 56, 58, 61CM



2RAS6C, 2RAS6T

SYNAPSE ALLOY 6 TIAGRA

INDIGO BLUE (GLOSS) (BLU).

JET BLACK (MATTE) (BBQ).

FRAME	SYNAPSE ALLOY, OPTIMIZED 6061 ALLOY, SAVE PLUS	TIRES	SCHWALBE LUGANO, 700X25C	SHIFTERS	SHIMANO TIAGRA 4600
FORK	SYNAPSE SAVE, CARBON BLADES	CRANKS	FSA OMEGA, BB30, 50/34	BRAKES	CANNONDALE C4, DUAL PIVOT, LONG REACH
WHEELS	MADDUX RS 3.0, 32 HOLE	DERAILLEURS	SHIMANO TIAGRA 4600	SIZES	48, 51, 54, 56, 58, 61CM



2RAS5C, 2RAS5T

SYNAPSE ALLOY 5 105

MAGNESIUM WHITE (GLOSS) (WHT).

BRUSHED ALUMINUM (GLOSS) (RAW).

FRAME	SYNAPSE ALLOY, OPTIMIZED 6061 ALLOY, SAVE PLUS	TIRES	SCHWALBE LUGANO, 700X25C	SHIFTERS	SHIMANO 105 5700
FORK	SYNAPSE SAVE, CARBON BLADES	CRANKS	FSA GOSSAMER, BB30, 50/34	BRAKES	TEKTRO R539, DUAL PIVOT, LONG REACH
WHEELS	SHIMANO RS10	DERAILLEURS	SHIMANO 105 5700	SIZES	48, 51, 54, 56, 58, 61CM



2RAS7T

SYNAPSE ALLOY 7 SORA

MAGNESIUM WHITE (GLOSS) (WHT).

RACE RED (GLOSS) (RED).

FRAME	SYNAPSE ALLOY, OPTIMIZED 6061 ALLOY, SAVE PLUS	TIRES	SCHWALBE LUGANO, 700X25C	SHIFTERS	SHIMANO SORA
FORK	SYNAPSE SAVE, CARBON BLADES	CRANKS	FSA VERO, 50/39/30	BRAKES	CANNONDALE C4, DUAL PIVOT, LONG REACH
WHEELS	MADDUX RS 3.0, 32 HOLE	DERAILLEURS	SHIMANO SORA	SIZES	48, 51, 54, 56, 58, 61CM

SLICE

TIME. TESTED.

AS THE MULTIPLE IRONMAN WORLD CHAMPIONSHIPS AND WORLD RECORDS CAN ATTEST, THE SLICE'S BLEND OF AERODYNAMICS, LIGHT WEIGHT AND *AERO SAVE* COMFORT FEATURES IS A WINNING FORMULA. FIND YOUR NEW FAST.

VICTORIES
6X WORLD RECORD BREAKER

2011 Full Distance World Record
2010 Full Distance World Record
2009 Ironman World Champion and Full Distance World Record



2RM4D
SLICE CARBON 4 FORCE

FRAME	SLICE, FULL CARBON, AERO SAVE
FORK	SLICE AERO, FULL CARBON
WHEELS	FULCRUM RACING 7

TIRES	SCHWALBE LUGANO, 700X23C, FOLDING
CRANKS	SRAM S500 BB30, 53/39
DERAILLEURS	SRAM FORCE

SHIFTERS	SRAM TT500
BRAKES	SRAM RIVAL
SIZES	51, 54, 56, 58, 60CM

MAGNESIUM WHITE W/ JET BLACK AND RACE RED (GLOSS) (WHT).

> RIDE SMOOTHER. RUN FRESHER

The Slice's **AERO SAVE** rear stays deflect vertically to absorb road shock, while staying extremely stiff laterally and torsionally. Great power transfer and comfort that delivers you to the run feeling fresh.

> SUPERB GEOMETRY

The refined geometry and two-position aero seatpost enable riders to find their perfect aero position. The stable, predictable handling and **AERO SAVE** features help them stay in it longer.

> SPEED SHADOW SEAT TUBE

The shape of the **SPEED SHADOW** seat tube helps smooth out turbulent airflow and pass it smoothly over the rear wheel, reducing drag and increasing speed.



2RM5D
SLICE 5 105

FRAME	SLICE, FULL CARBON, AERO SAVE
FORK	SLICE AERO, FULL CARBON
WHEELS	SHIMANO R501A

TIRES	SCHWALBE LUGANO, 700X23C, FOLDING
CRANKS	FSA GOSSAMER PRO BB30, 52/38
DERAILLEURS	SHIMANO 105 5700

SHIFTERS	MICROSHIFT BAR-END
BRAKES	TEKTRO R580
SIZES	51, 54, 56, 58, 60CM

MAGNESIUM WHITE W/ JET BLACK AND RACE RED (GLOSS) (WHT).



CHRISSIE WELLINGTON.
3X WORLD IRONMAN CHAMPION.
"OVER THE PAST TWO YEARS MY SLICE AND I HAVE WON THE WORLD IRONMAN CHAMPIONSHIPS, BROKEN TWO WORLD RECORDS AND SIX COURSE RECORDS. THE BIKE LEAVES MY LEGS FRESHER FOR THE RUN. IT TRULY IS THE PERFECT PARTNERSHIP!"

SUPERX

REIGN. SUPREME.

VICTORIES & AWARDS



SUPER LIGHT. SUPER TOUGH. SUPER STIFF. SUPER SMOOTH. DESIGNED WITH INPUT FROM NATIONAL CHAMPIONS, SUPERX IS AN EXCEPTIONAL WEAPON FOR AN EXCEPTIONAL SPORT. DON'T JUST RACE THIS CROSS SEASON; REIGN.



2XC2C
SUPERX 2 SRAM RED

JET BLACK W/ BERSERKER GREEN (GLOSS) (GRN).

FRAME	SUPERX, BALLISTEC HI-MOD CARBON, SPEED SAVE
FORK	SUPERX, BALLISTEC HI-MOD FULL CARBON
WHEELS	MAVIC KSYRIUM ELITE

TIRES	SCHWALBE RACING RALPH, 700X33C
CRANKS	FSA SLK LIGHT CARBON, BB30, 46/36
DERAILLEURS	SRAM RED

SHIFTERS	SRAM RED
BRAKES	FSA SLK
SIZES	44, 48, 52, 54, 56, 58CM

> **BALLISTEC CARBON CONSTRUCTION**

High-strength fibers developed for **Ballistic** armoring and high-impact resins build remarkable strength into this ultralight frameset (1400 grams*)

*Frame and fork, size 56cm

> **SPEED SAVE MICRO-SUSPENSION SYSTEM**

The **SPEED SAVE** rear stay assembly combines flattened cross-sections with sophisticated carbon layup to create a system that offers incredible power transfer, yet acts as a micro-suspension system which absorbs shock and keeps you fresh and in control over rough terrain.

> **SYSTEM INTEGRATED FORK**

The oversized headtube houses a 1-1/8" to 1-1/4" tapered full carbon fork for the perfect balance of precise handling, strength and light weight.



2XC3C
SUPERX 3 ULTEGRA

MAGNESIUM WHITE W/ JET BLACK (GLOSS) (WHT).

FRAME	SUPERX, BALLISTEC CARBON, SPEED SAVE
FORK	SUPERX, BALLISTEC CARBON
WHEELS	MAVIC KSYRIUM EQUIPE

TIRES	SCHWALBE SAMMY SLICK 700X35C
CRANKS	FSA GOSSAMER PRO, BB30, 46/36
DERAILLEURS	SHIMANO ULTEGRA 6700

SHIFTERS	SHIMANO ULTEGRA 6700
BRAKES	TRP EURO-X ALLOY
SIZES	44, 48, 52, 54, 56, 58CM



2XC4C
SUPERX 4 RIVAL

MAGNESIUM WHITE W/ JET BLACK (GLOSS) (WHT).

FRAME	SUPERX, BALLISTEC CARBON, SPEED SAVE
FORK	SUPERX, BALLISTEC CARBON
WHEELS	FULCRUM RACING 7 CX

TIRES	SCHWALBE RAPID ROB, 700X35C
CRANKS	FSA GOSSAMER PRO, BB30, 46/36
DERAILLEURS	SRAM RIVAL

SHIFTERS	SRAM RIVAL
BRAKES	TRP EURO-X ALLOY
SIZES	44, 48, 52, 54, 56, 58CM

CAADX

CROSS. FUNCTIONAL.

GO OFF THE BEATEN PATH, TURBO CHARGE YOUR COMMUTE OR JUMP IN AT THE LOCAL 'CROSS RACE. WIPE OFF THE MUD, KEEP THE SMILE.



2XR5C

CAADX 5 105

BRUSHED ALUMINUM (GLOSS) (RAW).

FRAME	CAADX CYCLOCROSS, OPTIMIZED 6061 ALLOY
FORK	CANNONDALE ULTRA X, CARBON BLADES
WHEELS	MADDUX DRX 6000, 32 HOLE

TIRES	SCHWALBE SAMMY SLICK, 700X35C
CRANKS	FSA GOSSAMER, BB30, 46/36
DERAILLEURS	SHIMANO 105 5700

SHIFTERS	SHIMANO 105 5700
BRAKES	TEKTRO CR710
SIZES	44, 48, 51, 54, 56, 58, 61CM



2XR6C

CAADX 6 TIAGRA

JET BLACK (MATTE) (BBQ).

FRAME	CAADX CYCLOCROSS, OPTIMIZED 6061 ALLOY
FORK	CANNONDALE ULTRA X, CARBON BLADES
WHEELS	MADDUX DRX 6000, 32 HOLE

TIRES	SCHWALBE SAMMY SLICK, 700X35C
CRANKS	FSA OMEGA BB30, 46/36
DERAILLEURS	SHIMANO TIAGRA 4600

SHIFTERS	SHIMANO TIAGRA 4600
BRAKES	TEKTRO CR520
SIZES	44, 48, 51, 54, 56, 58, 61CM

> HEADS-UP RACE GEOMETRY

The CAADX has a slightly taller head tube and slacker head angle than the SuperX, providing a more comfortable upright position and super stable handling.

> CANNONDALE ALUMINUM EXPERTISE

With taper-butted, shaped tubes joined by our trademark double-pass smooth welds, CAADX continues our tradition of aluminum mastery.

> HOURGLASS SEAT STAYS

The hourglass shape of the seat stays offers significant vertical compliance for comfort and control over the harsh ruts and mud of 'cross, while remaining laterally rigid for power transfer and confident handling.

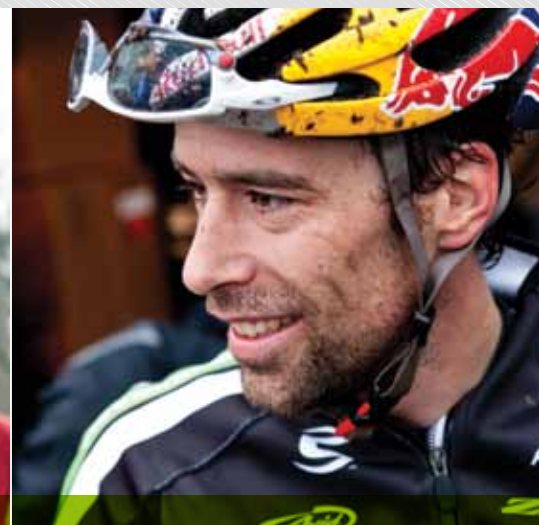

TIM JOHNSON.

CANNONDALE CYCLOCROSS WORLD PRO RIDER 6X NATIONAL CHAMPION

"CROSS IS: UP AND DOWN, ON AND OFF, BRAKE AND GAS, RIGHT AND LEFT, TWIST AND TURN, PUSH AND PULL. MY CANNONDALE ALLOWS ME TO PUSH WHERE I SHOULDN'T, PUSH WHEN NO ONE ELSE CAN, PUSH THROUGH TO THE FINISH LINE..."

> MOUNTAIN

OVERMOUNTAIN

CLAYMORE	34-37
JEKYLL	38-41

FULL SUSPENSION

RZ ONE TWENTY	46-47
LEFTY / HEADSHOK	42-45
SCALPEL	48-51

HARDTAIL

FLASH	52
TRAIL	53-55

29"ER

SCALPEL 29"ER	56-59
FLASH 29"ER	60-65
TRAIL 29"ER	66-69



CLAYMORE

NO. LIMITS.

THE CLAYMORE IS A TWO-BIKES-IN-ONE TRAIL WEAPON. AT A FLICK OF THE SWITCH, THE CLAYMORE CHANGES FROM A 110MM-TRAVEL ALL-AROUND TRAIL BIKE TO A 180MM-TRAVEL DOWNHILL CHARGER. EXPAND YOUR BATTLEFIELD.

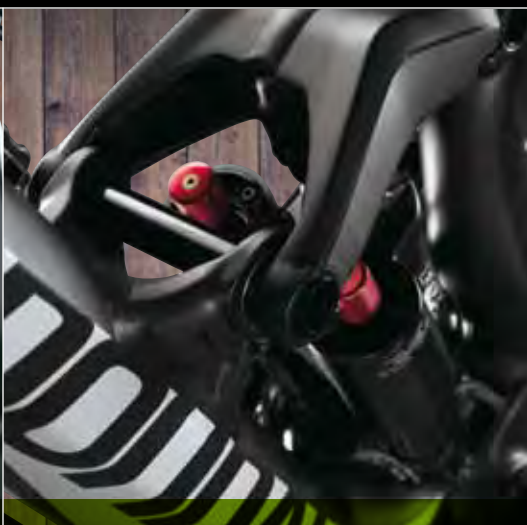

> DYAD RT2 – ADJUST YOUR ATTITUDE

A two-position shock mount lets you choose your starting geometry, then **DYAD's** dual modes, Elevate (110mm) and Flow (180mm), let you further tune the geometry and ride-feel on the fly. It is like having two different bikes at the flick of a switch.

> ECS-TC THRU-AXLES

The **ECS-TC** (Enhanced Center Stiffness – Torsion Control) System is all about reducing flex at pivots and links. 15mm thru-axles at the shock link and main pivot are clamped on both sides, tying the two sides together. This dramatically increases stiffness for instant responsiveness and control.

> DOUBLE-STACKED REAR DROPOUT PIVOT BEARINGS

As part of the **ECS-TC** System, we double-stack the bearings at the rear dropout pivots. By placing two bearings side-by-side in each pivot, we eliminate twisting play in the bearings, radically stiffening the swingarm.



ROAD
MOUNTAIN
RECREATION/URBAN
WOMEN'S
SPECIFICATIONS

2VA1 CLAYMORE 1

JET BLACK (MATTE) (BBQ).

FRAME	CLAYMORE, 180/110MM, SMARTFORMED ALLOY
SUSPENSION	FOX DYAD RT2 180-110MM / FOX TALAS R, 180MM
WHEELS	SUNRINGLE CHARGER PRO, TUBELESS READY

CRANKS	SRAM S1400, BB30, 36/22 W/ GUARD
DERAILLEURS, R/F	SHIMANO XT / SRAM X9
SHIFTERS	SHIMANO XT

BRAKES	AVID ELIXIR 9, 200/180MM
TIRES	SCHWALBE HANS DAMPF SNAKESKIN TRAILSTAR, 2.35" TUBELESS READY
SIZES	S, M, L



29ER
CLAYMORE 2

JET BLACK (MATTE) (BBQ)

FRAME	CLAYMORE, 180/110MM, SMARTFORMED ALLOY	CRANK	SRAM S1400, BB30, 36/22 W/ GUARD	BRAKES	AVID ELIXIR 7, 200/180MM
SUSPENSION (R/F)	FOX DYAD RT2 180-110MM / FOX VAN R O/B, 180MM	DERAILLEUR (R/F)	SRAM X9 / SRAM X7	TIRES	SCHWALBE HANS DAMPF PERFORMANCE, 2.35", FOLDING
WHEELS	SUNRINGLE INFERNO 27, 32 HOLE	SHIFTERS	SRAM X7	SIZES	S, M, L



AARON CHASE.
FREERIDE ICON,
OVERMOUNTAIN ATHLETE.
 "MY DEFINITION OF 'OVERMOUNTAIN'
 IS EXPLORING NATURE WITH
 ABSOLUTE A.D.D. THE BIKES ARE
 SO FAST AND SOLID, MAKING THE
 MOUNTAIN MY PLAYGROUND!"

HIGHLAND MOUNTAIN

AMERICA'S PREMIER MOUNTAIN BIKE PARK

Highland Mountain Bike Park- America's only 100% dedicated lift accessed bike park sits at the foothills of New England's White Mountains, just a short drive from the Boston Metro Area. Highland is globally recognized for its quality and innovation- everything at Highland is done with precision and dedication from trail building to having the top rental fleet in the industry, nothing is taken lightly.

Whether you're new to the sport or one of the world's best riders, Highland has something for everyone with an extensive network of trails allowing for some of the world's most progressive terrain.

Highland Camps allows riders to learn in a controlled environment, giving them the opportunity to take their riding to the next level while learning from some of the top athletes in the world.

OverMountain athlete Aaron Chase says it best- " The Crew at Highland never ceases to amaze me with their dedication and passion to the sport of mountain biking. Everything they touch is done to perfection, from the perfectly groomed trails to the details in the HTC training center- keep an eye out, because Highland is the future of our sport."

At Highland Mountain, you will find Cannondale **OverMountain** bikes ready to help you push it from the gentle Fancy Feast to the infamous Hellion.



JEKYLL

ATTITUDE. ADJUST.

THE MOST VERSATILE BIKE ON THE MOUNTAIN. FLOAT UP THE CLIMBS WITH AN EFFICIENT 90MM-TRAVEL TRAIL MACHINE. ROCK THE DESCENTS WITH A PLUSH 150MM OF LONG-TRAVEL GOODNESS. RIDE ANYWHERE. RIDE ANYTHING. EXPAND YOUR BOUNDARIES.

VICTORIES & AWARDS



"2011 Editor's Choice"

"Might just be the ultimate mountain bike."
-Bike, USA 1/11

"This bike changes the trail riding experience and takes mountain biking to a whole new extreme." "There's truly no other bike that can compete against the Jekyll 1000."
-Bicycling, USA 5/11

ROAD
MOUNTAIN
RECREATION/URBAN
WOMEN'S
SPECIFICATIONS

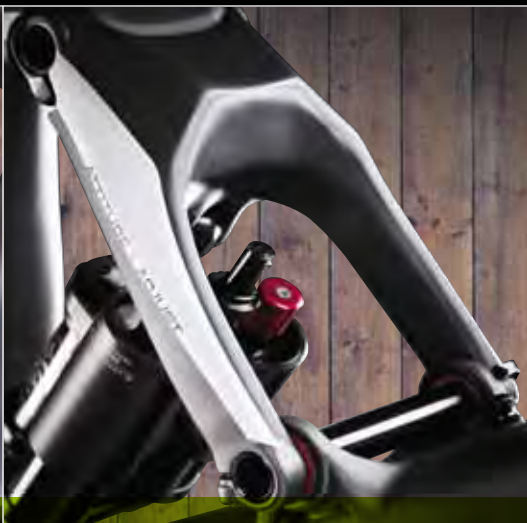

> DYAD RT2 – ADJUST YOUR ATTITUDE

The **DYAD** shock gives the Jekyll its two different personalities – **Elevate** (90mm) and **Flow** (150mm). Each with its own air spring volume and damping circuits, and its own ride geometry. It is like having two different bikes available to you at the flick of a switch.

> ECS-TC SYSTEM

The **ECS-TC** (Enhanced Center Stiffness-Torsion Control) System uses features like these clamped 15mm thru-axles and doubled bearings at the rear dropouts to eliminate flex and play in the links and pivots. This removes the vague, imprecise feeling felt on so many dual suspension bikes.

> LIGHT AND TOUGH

In either **BallisTec** Carbon or **SmartFormed** Alloy, the incredibly light, unbelievably tough Jekyll frames let you climb with the whippets but descend with the pitbulls.

2VN1 JEKYLL CARBON 1

FRAME	JEKYLL, 150/90MM, BALLISTEC HI-MOD CARBON
SUSPENSION	FOX DYAD RT2 150-90MM / FOX 32 TALAS RLC FIT, 150MM
WHEELS	MAVIC CROSSMAX ST, TUBELESS

CRANKS	SRAM S2210, BB30, 38/24 W/ GUARD
DERAILLEURS, R/F	SHIMANO XTR / SRAM X9
SHIFTERS	SHIMANO XT

BRAKES	AVID ELIXIR 9 CARBON, 180/180MM
TIRES	SCHWALBE HANS DAMPF SNAKESKIN TRAILSTAR, 2.35" TUBELESS READY
SIZES	S, M, L, X

EXPOSED CARBON W/ MAGNESIUM WHITE(GLOSS) (WHT).



2VN2
JEKYLL CARBON 2

CHARCOAL GRAY (MATTE) (GRY).

FRAME	JEKYLL, 150/90MM, BALLISTEC HI-MOD CARBON	CRANKS	SRAM S2210, BB30, 38/24 W/ GUARD	BRAKES	AVID ELIXIR 7 CARBON, 180/180MM
SUSPENSION	FOX DYAD RT2 150-90MM / FOX 32 TALAS RL, 150MM	DERAILLEURS, R/F	SRAM X9 / SRAM X7	TIRES	SCHWALBE HANS DAMPF SNAKESKIN TRAILSTAR, 2.35" TUBELESS READY
WHEELS	SUNRINGLE BLACKFLAG EXPERT +, TUBELESS READY	SHIFTERS	SRAM X9	SIZES	S, M, L, X



2VN4
JEKYLL ALLOY 4

MAGNESIUM WHITE (GLOSS) (WHT).

FRAME	JEKYLL, 150/90MM, SMARTFORMED ALLOY	CRANKS	SRAM S1000 3.3, 44/33/22	BRAKES	AVID ELIXIR 3, 180/180MM
SUSPENSION	FOX DYAD RT2 150-90MM / ROCKSHOX SEKTOR TK, 150MM	DERAILLEURS, R/F	SRAM X7 / X7	TIRES	SCHWALBE HANS DAMPF SNAKESKIN TRAILSTAR, 2.35" TUBELESS READY
WHEELS	SUNRINGLE INFERNO25	SHIFTERS	SRAM X5	SIZES	S, M, L, X



2VN3
JEKYLL ALLOY 3

JET BLACK (GLOSS) (BLK).

FRAME	JEKYLL, 150/90MM, SMARTFORMED ALLOY	CRANKS	SRAM S1400, BB30, 44/33/22	BRAKES	AVID ELIXIR 7, 180/180MM
SUSPENSION	FOX DYAD RT2 150-90MM / FOX 32 TALAS RL, 150MM	DERAILLEURS, R/F	SHIMANO XT / SRAM X7	TIRES	SCHWALBE HANS DAMPF SNAKESKIN TRAILSTAR, 2.35" TUBELESS READY
WHEELS	SUNRINGLE INFERNO25	SHIFTERS	SHIMANO SLX	SIZES	S, M, L, X



MARK WEIR.
OVERMOUNTAIN AGGRESSIVE ENDURANCE SPECIALIST.
"THE JEKYLL GIVES SPEED UP OR DOWN BY THE FLICK OF A LEVER. IT'S A NEW TRAIL WEAPON FOR THOSE WHO WANT THE BEST OF BOTH WORLDS. ON POWER EFFICIENCY WITH FULL DOWNHILL CAPABILITY."

LEFTY/HEADSHOK

LIGHTER. STRONGER. STIFFER. SMOOTHER. DEFY. CONVENTION.

THE MOUNTAIN BIKE WORLD CAN BE DIVIDED INTO TWO BASIC GROUPS: PEOPLE WHO LOVE LEFTY, AND PEOPLE WHO HAVEN'T YET TRIED LEFTY. THERE ISN'T A LOT OF MIDDLE GROUND BECAUSE MOST PEOPLE WHO RIDE LEFTIES FIND THEY SIMPLY CAN'T GO BACK TO RIDING OTHER FORKS.



> DON'T SLIDE. ROLL

Rather than sliding on bushings like other forks, **Lefty** rolls smoothly on precision-ground needle bearings. These bearings eliminate friction and allow the **Lefty** to remain plush and active under loads that would cause a bushing fork to bind and stick. Better suspension equals better control.



> OPI

Our patented 3D forging process, used for parts like the **OPI** outer leg/clamp structure, the **OPI** inner leg/axle structure, and our **OPI** stem/steerer, integrates multiple parts into single forged pieces, reducing overall weight and increasing strength.



> SUPERIOR DESIGN

Lefty's inverted double-clamp design is stiffer, stronger and lighter than the normal single crown designs. When **System Integrated** with the **OPI** stem/steerer, it forms the lightest, most precise suspension system available.



> LEFTY IS LIGHTER.

Our lightest Lefty, the **SPEED Carbon XLR**, weighs an unbelievable 1250g. Even our heaviest Lefty, at 1445 grams, is lighter than most of our competitors lightest race offerings.

> LEFTY IS STRONGER.

XC weight meets dirt jumper tough. Lefty's unconventional inverted design, with its oversized steerer, massive outer tube and beefy dual crowns, gives even the lightest carbon Lefty the strength to go head-to-head in destructive testing with forks designed for much more abusive riding.

> LEFTY IS STIFFER.

Despite weighing less than the lightest XC race forks, Lefty's stout structure combined with its "square-in-a-square" stanchion design allow it to post deflection numbers comparable with the burliest thru-axle forks. Testing proves Lefty beats out traditional all-mountain and freeride forks in stiffness to weight. (Tested by Bike magazine Germany, January 2011)

> LEFTY IS SMOOTHER.

The heart of all HeadShok and Lefty designs, Cannondale's patented 88 Needle Bearing Technology keeps the suspension rolling fluidly, regardless of load. Unlike with normal bushing forks, hard braking, impacts and steering forces have no effect on the shock's ability to move, which allows the wheel to track the ground freely and keeps the rider in perfect control.

> LEFTY CARBON XLR

FILAMENT WOUND CARBON OUTER LEG, ALLOY CLAMPS

OPI 3D-FORGED INNER LEG/SPINDLE

SEALED CARTRIDGE XLR DAMPER W/ POPTOP BLOW-OFF THRESHOLD PISTON AND XLOC™ REMOTE LEVER

Lefty Carbon XLR is available in these configurations.

LEFTY MAX CARBON XLR – 140MM TRAVEL, 1315 GR.

LEFTY ULTRA CARBON XLR – 120MM TRAVEL, 1320 GR.

LEFTY SPEED CARBON XLR – 100MM TRAVEL, 1250 GR.

LEFTY 29'ER CARBON XLR – 90 OR 100MM TRAVEL, 1332 GR.

LEFTY CARBON XLR



> LEFTY XLR

OPI 3D-FORGED OUTER LEG/CLAMPS

OPI 3D-FORGED INNER LEG/SPINDLE

SEALED CARTRIDGE XLR DAMPER W/ POPTOP BLOW-OFF THRESHOLD PISTON AND XLOC™ REMOTE LEVER

Lefty XLR is available in these configurations.

LEFTY ULTRA XLR – 120MM TRAVEL, 1440 GR.

LEFTY SPEED XLR – 100MM TRAVEL, 1394 GR.

LEFTY 29'ER XLR – 90 OR 100MM TRAVEL, 1445 GR.

LEFTY XLR



> LEFTY PBR

OPI 3D-FORGED OUTER LEG/CLAMPS

OPI 3D-FORGED INNER LEG/SPINDLE

SEALED CARTRIDGE DAMPER W/ POPTOP BLOW-OFF THRESHOLD PISTON AND PUSH-BUTTON ACTUATION

Lefty PBR is available in these configurations.

LEFTY ULTRA PBR – 120MM TRAVEL, 1391 GR.

LEFTY SPEED PBR – 100MM TRAVEL, 1334 GR.

LEFTY 29'ER PBR – 90 OR 100MM TRAVEL, 1408 GR.

LEFTY PBR



> FATTY DLR

OPI AIR-FORMED ONE-PIECE LEGS

SEALED CARTRIDGE DLR DAMPER W/ TOP MOUNT LOCKOUT

Fatty DLR is available in this configuration.

HEADSHOK FATTY DLR – 80MM TRAVEL, 1275 GR.

FATTY DLR



SRAM

> TWEAK. REFINE. TWEAK. REFINE. LEAP AHEAD.

CANNONDALE IS EXCITED TO PARTNER WITH SRAM ON MANY OF OUR PREMIER TEAMS AS WELL AS ON MANY OF OUR PRODUCTS. SRAM IS THE CHOICE OF LIQUIGAS-CANNONDALE, CANNONDALE FACTORY RACING, CANNONDALE CYCLOCROSSWORLD AND MANY OF OUR WORLD-CLASS ATHLETES.

SRAM RED: THE PRO GRUPPO

SRAM RED is the first choice for riders and racers who won't accept any compromise. The most challenging races in the world have been won on SRAM RED, including the Tour de France, Giro d'Italia and Paris-Roubaix. Liquigas-Cannondale is SRAM RED-equipped. Its success in the pro peloton speaks for itself. Featured on the SuperSix EVO, the Synapse Hi-MOD and the SuperX.

SRAM APEX: WHEREVER THE ROAD TAKES YOU

You like to climb long mountain passes, or your local hill, but don't want clumsy triple cranks on your bike? With the first 11-32 cassette for the road, and the new SRAM Apex compact crankset, you will have a wider gear range than the most popular triple combinations. Climb and descend more efficiently with SRAM features like Zero-loss, reach-adjust, and DoubleTap shifting. Featured on the Synapse.

ZIPP 303 CX

The qualities that make the 303 ideal for "road" races like Paris-Roubaix also make it the ultimate cyclocross wheelset. Despite its toughness and stability, the 303 Cyclocross is lighter than many dedicated climbing wheelsets. At just 1206 grams, the 303 provides excellent lateral stiffness when accelerating out of technical corners and punching over short, steep hills.



RZ ONE TWENTY

JUST. RIGHT.

120MM OF BALANCED FRONT AND REAR TRAVEL COMBINED WITH IMPECCABLY REFINED HANDLING MAKE THE LIGHT, EFFICIENT RZ PLATFORM THE PERFECT BIKE FOR LONG TRAIL RIDES OR YOUR FAVORITE MARATHON EVENT.



2VL2

RZ ONE TWENTY 2

MAGNESIUM WHITE (GLOSS) (WHT).

JET BLACK (GLOSS) (BBQ).

FRAME RZ ONE TWENTY, 120MM, SMARTFORMED ALLOY

CRANKS SHIMANO M552, 42/32/24

BRAKES AVID ELIXIR 3, 180/160MM

SUSPENSION ROCKSHOX MONARCH RT / ROCKSHOX RECON GOLD TK, 120MM

DERAILLEURS, R/F SHIMANO XT / SLX

TIRES SCHWALBE RAPID ROB, 2.25"

WHEELS SUNRINGLE SR25

SHIFTERS SHIMANO SLX

SIZES S, M, L, X

STAGED TRAVEL

The RZ's refined single pivot design offers optimal suspension response throughout the travel. The stroke is super plush at the beginning, linear and predictable through the middle, with a firm ramp at the end for a bottomless feel.

CANNONDALE ALUMINUM EXPERTISE

The RZ showcases decades of aluminum mastery. **SmartFormed** tubes, double-pass smooth welds and the 3D forged **OPI** (One Piece Integration) **Backbone** BB/main pivot/ seat-tube structure deliver maximum strength with minimal weight

SUPERB HANDLING

The perfect mix of stable and racy, the RZ's geometry lets you feel at home and in control no matter what the mountain throws your way. Truly at its best when **System Integrated** with the unbeatable **Lefty** fork.



2VL3

RZ ONE TWENTY 3

FINE SILVER (MATTE) (SLV).

JET BLACK (MATTE) (BBQ).

FRAME RZ ONE TWENTY, 120MM, SMARTFORMED ALLOY

CRANKS SRAM S800 3.2, 44/33/22

BRAKES AVID ELIXIR 1, 180/160MM

SUSPENSION X FUSION E1RL / ROCKSHOX RECON SILVER TK, 120MM

DERAILLEURS, R/F SRAM X5 / X5

TIRES SCHWALBE RAPID ROB, 2.25"

WHEELS MADDUX DC 3.0

SHIFTERS SRAM X5

SIZES S, M, L, X



MBR.

UK 03/11.

"COMFORTABLE AND CONFIDENT, IT ALLOWS YOU TO SIMPLY GET ON WITH YOUR RIDING."

SCALPEL

CUTTING. EDGE.

THE LIGHTEST, STIFFEST, MOST RESPONSIVE DUAL SUSPENSION XC RACE BIKE IN THE WORLD. WITH RACE PROVEN *ZERO PIVOT* TECHNOLOGY, *BALLISTEC* CARBON CONSTRUCTION AND FULL *SYSTEM INTEGRATED* COMPONENTRY, THE SCALPEL IS THE ULTIMATE CROSS-COUNTRY RACE WEAPON.

VICTORIES AND AWARDS



ROAD
MOUNTAIN
RECREATION/URBAN
WOMEN'S
SPECIFICATIONS



SYSTEM INTEGRATION

Scalpel is **System Integration**. We achieve unbelievable weight saving and efficiency by designing components and frames to work together. Our **Lefty** fork, **Si OPI** Stem, and **Hollowgram** SL BB30 crankset give us system stiffness and weights that our competitors can only dream of.

BALLISTEC CARBON

The Scalpel frame weighs just 1590 grams with shock! Made primarily from ballistic armoring fibers and high-impact resins, our **BallisTec** carbon construction ensures that its feathery weight doesn't come at the expense of strength or stiffness. Race with confidence.

ZERO PIVOT

Scalpel achieves 80mm of efficient, progressive rear suspension without pivots, bushings or bearings. Through radically advanced carbon lay-up and shaping, the seatstays and chainstays are allowed to flex vertically while maintaining best-in-class lateral and torsional stiffness-to-weight numbers. Pure efficiency.



2VP0

SCALPEL TEAM

FRAME	SCALPEL, 80MM, BALLISTEC HI-MOD CARBON, ZERO PIVOT
SUSPENSION	ROCKSHOX MONARCH RT3 / LEFTY SPEED CARBON XLR, 100MM
WHEELS	MAVIC CROSSMAX SLR, TUBELESS

CRANKS	CANNONDALE HOLLOWGRAM SL, 39/26
DERAILLEURS, R/F	SRAM XX / XX
SHIFTERS	SRAM XX

BRAKES	AVID XX WORLD CUP, 160/140MM
TIRES	SCHWALBE FURIOUS FRED PACESTAR, 26X2.0" TUBELESS READY
SIZES	S, M, L, X

EXPOSED CARBON W/ BERSERKER GREEN (GLOSS) (REP).



2VP2
SCALPEL 2

JET BLACK W/ MAGNESIUM WHITE (GLOSS) (BLK)

FRAME	SCALPEL, 80MM, BALLISTEC HI-MOD CARBON, ZERO PIVOT	CRANKS	SRAM S2210, BB30, 39/26	BRAKES	AVID ELIXIR 9 CARBON 160/140MM
SUSPENSION	ROCKSHOX MONARCH RT / LEFTY SPEED XLR, 100MM	DERAILLEURS, R/F	SRAM X0 / X9	TIRES	SCHWALBE RACING RALPH PACESTAR, 2.1" TUBELESS READY
WHEELS	SUNRINGLE BLACKFLAG PRO, TUBELESS READY	SHIFTERS	SRAM X9	SIZES	S, M, L, X



2VP3
SCALPEL 3

RACE RED W/ MAGNESIUM WHITE (GLOSS) (RED)

FRAME	SCALPEL, 80MM, BALLISTEC HI-MOD CARBON, ZERO PIVOT	CRANKS	SRAM S1400, BB30, 39/26	BRAKES	AVID ELIXIR 7, 160/140MM
SUSPENSION	ROCKSHOX MONARCH RT / LEFTY SPEED PBR, 100MM	DERAILLEURS, R/F	SHIMANO XT / SRAM X7	TIRES	SCHWALBE RACING RALPH PACESTAR, 2.1" TUBELESS READY
WHEELS	DT SWISS XCR 1.7 CUSTOM, TUBELESS READY	SHIFTERS	SHIMANO SLX	SIZES	S, M, L, X



JOHN HUSEBY.
CANNONDALE MOUNTAIN
PRODUCT DIRECTOR.

"THE 2011 SCALPEL IS A FULL-BLOWN, PURPOSE-BUILT, DAMN-THE-TORPEDOES, GO-FAST, PROFESSIONAL XC RACE RIG. IF YOUR IDEA OF FUN INVOLVES OXYGEN DEBT, LYCRA AND PUTTING THE HURT ON YOUR RIDING PARTNERS, THEN SCALPEL IS THE BIKE FOR YOU."

FLASH

FLASH. FORWARD.

A PURE RACER. WITH ITS ULTRA-LIGHT *SMARTFORMED* FRAME AND *SPEED SAVE* MICRO-SUSPENSION STAYS, THE FLASH ALLOY CAN PUT YOU ON THE PODIUM - WITH MONEY LEFT OVER FOR THE IMPORTANT THINGS, LIKE RACE FEES AND MEDAL CASES.



2FA3	FLASH ALLOY 3		MAGNESIUM WHITE W/ BERSERKER GREEN (GLOSS) (WHT).	JET BLACK (GLOSS) (BLK).	
FRAME	FLASH, SMARTFORMED ALLOY, SPEED SAVE	CRANKS	SHIMANO M552, 42/32/24	BRAKES	AVID ELIXIR 1, 160/160MM
FORK	FATTY DLR80, 80MM, OPI	DERAILLEURS, R/F	SHIMANO XT / DEORE	TIRES	SCHWALBE RAPID ROB, 2.1"
WHEELS	MADDUX DC3.0	SHIFTERS	SHIMANO SLX	SIZES	S, M, L, X

> SUPER LIGHT WEIGHT

At just 1450 grams, the Flash Alloy frame is lighter than many of our competitors' carbon race bikes.

> CANNONDALE ALUMINUM

Flash's sophisticated **SmartFormed** tubing, and trademark double-pass smooth welds showcase our almost 3 decades of aluminum supremacy.

> SPEED SAVE REAR STAYS

Careful shaping and wall thickness manipulation on the chain stays and seat stays allows them to deflect vertically while remaining stiff laterally and torsionally, absorbing shock and enhancing control.

TRAIL SL AND TRAIL

TRAIL. BLAZER.

PACKED WITH FEATURES AND TECHNOLOGY FROM ITS UPPER END SIBLINGS, THE TRAIL IS THE BIKE THAT WILL USHER YOU FOREVER INTO THE WORLD OF FAT TIRES, OFF ROAD TRAILS AND BIG SMILES. LET THE GOOD TIMES BEGIN.



2FS2	TRAIL SL 2		JET BLACK (GLOSS) (BLK2).	RACE RED (GLOSS) (RED).	
FRAME	TRAIL SL, OPTIMIZED 6061 ALLOY	CRANKS	SRAM S800 3.1, 44/33/22	BRAKES	AVID ELIXIR 1, 160/160MM
FORK	ROCKSHOX RECON SILVER TK, 100MM	DERAILLEURS, R/F	SRAM X5 / X5	TIRES	SCHWALBE RAPID ROB, 2.1"
WHEELS	MADDUX DC3.0	SHIFTERS	SRAM X5	SIZES	S, M, L, X, J

> RACE DNA

The Trail bikes have racing in their blood. They share the geometry and many of the features of their Flash brethren for a ride that is fast, snappy and agile. The Trail SL's all use 1.5" steerers for increased strength and stiffness.

> CANNONDALE ALUMINUM CRAFTING

The Trail's purposefully shaped tubes, internal taper-butting and trademark double-pass smooth welds highlight Cannondale's aluminum expertise.

> SAVE COMFORT ENHANCING REAR STAYS.

The chain stays and seat stays are designed to work together to absorb shock, while preventing side-to-side and twisting flex. This adds up to better comfort and great power transfer.



2FS3
TRAIL SL 3 JET BLACK (GLOSS) (BLK) MAGNESIUM WHITE (GLOSS) (WHT)

FRAME	TRAIL SL, OPTIMIZED 6061 ALLOY	CRANKS	SHIMANO FC-M430-8 OCTALINK, 44/32/22	BRAKES	SHIMANO BR-M446 HYDRAULIC DISC, 160/160MM
FORK	RST DEUCE COIL, 100MM	DERAILLEURS, R/F	SHIMANO DEORE / ALIVIO	TIRES	SCHWALBE RAPID ROB, 2.1"
WHEELS	MADDOX DC3.0	SHIFTERS	SHIMANO ALIVIO	SIZES	S, M, L, X, J



2FT5
TRAIL 5 INDIGO BLUE (GLOSS) (BLU) FINE SILVER (GLOSS) (SLV)

FRAME	TRAIL, DOUBLE BUTTED 6061 ALLOY, SAVE	CRANKS	SHIMANO, FC-M311, 42/32/22	BRAKES	PROMAX MECHANICAL DISC, 160/160MM
FORK	RST BLAZE PRO TNL, 100MM	DERAILLEURS, R/F	SHIMANO ACERA / M310	TIRES	KENDA SMALL BLOCK 8, 2.1"
WHEELS	ALEX DC4.5	SHIFTERS	SHIMANO ACERA	SIZES	S, M, L, X, J



2FS4
TRAIL SL 4 CHARCOAL GREY (MATTE) (GRY) MAGNESIUM WHITE (GLOSS) (WHT)

FRAME	TRAIL SL, OPTIMIZED 6061 ALLOY	CRANKS	SHIMANO FC-M361, 42/32/22	BRAKES	CANNONDALE HELIX 6 HYDRAULIC DISC, 160/160MM
FORK	RST DEUCE TNL, 100MM	DERAILLEURS, R/F	SHIMANO ALIVIO / ALTUS	TIRES	SCHWALBE RAPID ROB, 2.1"
WHEELS	MADDOX DC3.0	SHIFTERS	SHIMANO ALTUS	SIZES	S, M, L, X, J



2FT6
TRAIL 6 MAGNESIUM WHITE (GLOSS) (WHT) JET BLACK (MATTE) (BBQ)

FRAME	TRAIL, DOUBLE BUTTED 6061 ALLOY, SAVE	CRANKS	SHIMANO, FC-M191, 42/34/24	BRAKES	TEKTRO NOVELA MECHANICAL DISC, 160/160MM
FORK	RST BLAZE T, 100MM	DERAILLEURS, R/F	SHIMANO ALTUS / M190	TIRES	KENDA SMALL BLOCK 8, 2.1"
WHEELS	ALEX DC4.5	SHIFTERS	SHIMANO M310	SIZES	S, M, L, X, J

SCALPEL 29'ER

SMOOTH. OPERATOR.

THE SCALPEL 29'ER TAKES FEATURES FROM THE FLASH 29'ER, SCALPEL, RZ AND OVERMOUNTAIN BIKES AND BLENDS THEM INTO AN ALL NEW LIGHTWEIGHT TRAIL ROCKET. FOR ROUGHER RACES, MARATHONS AND EPIC TRAILS THE WORLD OVER, THE SCALPEL 29'ER IS YOUR INSTRUMENT — GET READY TO OPERATE.

ROAD
MOUNTAIN
RECREATION/URBAN
WOMEN'S
SPECIFICATIONS



> ZERO PIVOT FLEXING SEAT STAYS

Thanks to radically advanced carbon construction, our **Zero Pivot** Flexing Seat Stays deliver lateral and torsional rigidity that no single-bearing pivot can match, while also eliminating the pivot's unneeded weight. Pure efficiency.

> S1/SYSTEM INTEGRATED FRONT END

Our Lefty fork is Lighter, Stiffer, Smoother and Stronger than any other 29'er fork on the market by a significant margin. When you combine it with our -15 degree **DPI** Adjustable Stem/Steerer, you create the perfect 29'er front end. Maximum steering precision with minimal weight.

> ECS-TC THRU-AXLES AND SEAT STAY BRIDGE

For class-leading stiffness, we borrowed the **ECS-TC** clamped 15mm thru-axles from our OverMountain bikes, and added a stout integrated seat stay bridge/clamp. This configuration locks the two seat stays together and prevents rotational deflection for exceptional system stiffness.



2VP91

SCALPEL 29'ER CARBON 1

EXPOSED CARBON W/ MAGNESIUM WHITE (MATTE) (BBQ).

FRAME	SCALPEL 29'ER, 100MM, BALLISTEC HI-MOD FULL CARBON
SUSPENSION	FOX RP23 / LEFTY 29'ER CARBON XLR, 100MM
WHEELS	DT SWISS TRICON 1550 29'ER LEFTY, TUBELESS READY

CRANKS	CANNONDALE HOLLOWGRAM SL, 39/26 W/XX CHAINRINGS
DERAILLEURS, R/F	SRAM XX / XO
SHIFTERS	SRAM XX

BRAKES	AVID ELIXIR X0 CARBON, 180/160MM
TIRES	SCHWALBE RACING RALPH EVO, 2.25" TUBELESS READY
SIZES	S, M, L, X



2VP92
SCALPEL 29'ER CARBON 2

EXPOSED CARBON W/ MAGNESIUM WHITE (GLOSS) (BLK).

FRAME	SCALPEL 29'ER, 100MM, BALLISTEC HI-MOD FULL CARBON	CRANKS	SRAM S2210, BB30, 39/26	BRAKES	AVID ELIXIR 9 CARBON, 180/160MM
SUSPENSION	ROCKSHOX MONARCH RT3 / LEFTY 29'ER XLR, 100MM	DERAILLEURS, R/F	SHIMANO XTR / SRAM X9	TIRES	SCHWALBE RACING RALPH EVO, 2.25" TUBELESS READY
WHEELS	STAN'S ZTR ARCH 29'ER, TUBELESS READY	SHIFTERS	SHIMANO XT	SIZES	S, M, L, X



2VP94
SCALPEL 29'ER ALLOY 4

JET BLACK (GLOSS) (BLK).

FRAME	SCALPEL 29'ER, 100MM, SMARTFORMED ALLOY	CRANKS	FSA COMET, 42/32/24	BRAKES	AVID ELIXIR 3, 180/160MM
SUSPENSION	X FUSION E1RL / ROCKSHOX RECON GOLD TK 29, 100MM	DERAILLEURS, R/F	SHIMANO XT / SLX	TIRES	SCHWALBE RAPID ROB, 2.25"
WHEELS	SUNRINGLE INFERNO25	SHIFTERS	SHIMANO DEORE	SIZES	S, M, L, XL



2VP93
SCALPEL 29'ER ALLOY 3

MAGNESIUM WHITE (GLOSS) (WHT).

FRAME	SCALPEL 29'ER, 100MM, SMARTFORMED ALLOY	CRANKS	SRAM S1000, BB30, 39/26	BRAKES	AVID ELIXIR 5, 180/160MM
SUSPENSION	FOX RP2 / LEFTY 29'ER PBR, 100MM	DERAILLEURS, R/F	SRAM X9 / X7	TIRES	SCHWALBE RACING RALPH EVO, 2.25" TUBELESS READY
WHEELS	SUNRINGLE INFERNO25	SHIFTERS	SRAM X7	SIZES	S, M, L, X

JEREMIAH BISHOP.
CANNONDALE FACTORY RACING,
WON 8 CONSECUTIVE MTB
STAGE RACES.
 "THIS THING IS SO FAST AND MORE
 RESPONSIVE THAN I THOUGHT ANY
 29'ER FULL SUSPENSION BIKE
 COULD EVER BE! WOW!"



FLASH CARBON 29'ER

BIGGER. BETTER.

OUR FLASH 29'ERS SIMPLY ROCK. *BALLISTEC* CARBON AND *SPEED SAVE* FEATURES MAKE THEM LIGHT, STIFF AND SMOOTH, AND OUR 29'ER RACE GEOMETRY MIMICS THE WHEELBASE AND TRAIL OF OUR 26" RACE BIKES FOR INCREDIBLY NIMBLE HANDLING. ROLL ON.

VICTORIES & AWARDS



ROAD
MOUNTAIN
RECREATION/URBAN
WOMEN'S
SPECIFICATIONS



› SPEED SAVE ROLLS FASTER

The **SPEED SAVE** rear stays form a ride-tuned micro suspension system that is engineered not simply to add comfort but to help the bike roll faster, accelerate better and corner harder. The **SAVE** seatpost adds over 20mm of comfort enhancing flex to the system.

› SYSTEM INTEGRATION

29'ers love **Lefty**. It's true. The **Lefty's** incredible stiffness, light weight and smoothness are even more apparent with the big 29" wheels. When combined with the superlight **Si OPI** stem/steerer, and the **Hollowgram SL BB30** Cannondale's **System Integration** saves hundreds of grams over competitors' offerings.

› CONTINUOUS CARBON

On the Flash Carbon 29'er, continuous strands of high-modulus stiffening fibers run along the outer edges of all the tubes from head tube to rear dropouts. This network of fibers connects the key parts of the frame to increase lateral rigidity and responsiveness, while minimizing weight.

2FS290S

FLASH 29'ER CARBON ULTIMATE

FRAME	FLASH 29'ER, BALLISTEC HI-MOD CARBON, SPEED SAVE
FORK	LEFTY 29'ER CARBON XLR, 90MM
WHEELS	ENVE COMPOSITES TWENTY9 XC

CRANKS	CANNONDALE HOLLOWGRAM SL, BB30, 39/26 W/SRAM XX RINGS
DERAILLEURS, R/F	SRAM XX / XX
SHIFTERS	SRAM XX

EXPOSED CARBON W/ MAGNESIUM WHITE (MATTE) (BBQ).

BRAKES	SRAM XX WORLD CUP 160/140MM
TIRES	SCHWALBE RACING RALPH PACESTAR, 2.1" TUBELESS READY
SIZES	M, L, X



2FS291S
FLASH 29'ER CARBON 1

FINE SILVER W/ JET BLACK (GLOSS) (SLV).

FRAME	FLASH 29'ER, BALLISTEC HI-MOD CARBON, SPEED SAVE	CRANKS	SRAM S2210, BB30, 39/26	BRAKES	AVID X0 CARBON, 180/160MM
FORK	LEFTY 29'ER CARBON XLR, 90MM	DERAILLEURS, R/F	SHIMANO XTR / SRAM X0	TIRES	SCHWALBE RACING RALPH EVO, 2.25" TUBELESS READY
WHEELS	STAN'S ZTR ARCH 29'ER	SHIFTERS	SHIMANO XTR	SIZES	M, L, X



2FS292S
FLASH 29'ER CARBON 2

MAGNESIUM WHITE W/ JET BLACK (GLOSS) (WHT).

FRAME	FLASH 29'ER, BALLISTEC CARBON, SPEED SAVE	CRANKS	SRAM S2210, BB30, 39/26	BRAKES	AVID ELIXIR 9 CARBON, 180/160MM
FORK	LEFTY 29'ER XLR, 90MM	DERAILLEURS, R/F	SRAM X0 / X9	TIRES	SCHWALBE RACING RALPH EVO, 2.25" TUBELESS READY
WHEELS	STAN'S ZTR ARCH 29'ER	SHIFTERS	SRAM X9	SIZES	M, L, X



MANUAL FUMIC.
CANNONDALE FACTORY RACING.
MY FLASH 29'ER IS SO COMFORTABLE, BUT ALSO SO RACY. THE LEFTY MAKES IT STIFF AND STRONG. 29'ERS ARE THE NEW 26'ERS, RIGHT?



2FS293S
FLASH 29'ER CARBON 3

MAGNESIUM WHITE W/ JET BLACK (GLOSS) (WHT).

FRAME	FLASH 29'ER, BALLISTEC CARBON, SPEED SAVE	CRANKS	SRAM S1400, BB30, 39/26	BRAKES	AVID ELIXIR 9, 180/160MM
FORK	LEFTY 29'ER PBR, 90MM	DERAILLEURS, R/F	SHIMANO XT / SRAM X7	TIRES	SCHWALBE RACING RALPH EVO, 2.25" TUBELESS READY
WHEELS	SUNRINGLE INFERNO25	SHIFTERS	SHIMANO XT	SIZES	M, L, X



2FA291
FLASH 29'ER ALLOY 1

JET BLACK (MATTE) (BBQ).

FRAME	FLASH 29'ER, SMARTFORMED ALLOY, SPEED SAVE	CRANKS	SRAM S1400, BB30, 39/26	BRAKES	AVID ELIXIR 7, 180/160MM
FORK	LEFTY 29'ER PBR, 90MM	DERAILLEURS, R/F	SRAM X9 /X7	TIRES	SCHWALBE RAPID ROB, 2.25"
WHEELS	SUNRINGLE INFERNO25	SHIFTERS	SRAM X9	SIZES	M, L, X



2FA293
FLASH 29'ER ALLOY 3

JET BLACK (GLOSS) (BLK).

FRAME	FLASH 29'ER, SMARTFORMED ALLOY, SPEED SAVE	CRANKS	SHIMANO M552, 42/32/24	BRAKES	AVID ELIXIR 1, 180/160MM
FORK	ROCKSHOX RECON GOLD TK 29, 80MM	DERAILLEURS, R/F	SHIMANO SLX / DEORE	TIRES	SCHWALBE RAPID ROB, 2.25"
WHEELS	MADDUX DC3.0 29'ER	SHIFTERS	SHIMANO SLX	SIZES	M, L, X



2FA292
FLASH 29'ER ALLOY 2

MAGNESIUM WHITE (GLOSS) (WHT).

FRAME	FLASH 29'ER, SMARTFORMED ALLOY, SPEED SAVE	CRANKS	SRAM S1000, BB30, 44/33/22	BRAKES	AVID ELIXIR 3, 180/160MM
FORK	LEFTY 29'ER PBR, 90MM	DERAILLEURS, R/F	SRAM X9 / X7	TIRES	SCHWALBE RAPID ROB, 2.25"
WHEELS	SUNRINGLE INFERNO25	SHIFTERS	SRAM X7	SIZES	M, L, X



SOME THINGS ARE TRULY TIMELESS - LIKE MASTERS NATIONAL CHAMPION, TINKER JUAREZ, OR THE FEEL OF A WELL-CRAFTED ALUMINUM FRAME, LIKE THE FLASH ALLOY.

TRAIL SL 29'ER

BIG. EASY.

PERFECT FOR A FIRST-TIMER, TRAIL SL 29'ERS MAKE THE GOING EASY. 29" WHEELS ROLL EFFORTLESSLY WHILE STABLE GEOMETRY INSPIRES CONFIDENCE. GET GOING.



2FS292

TRAIL SL 29'ER 2

JET BLACK (MATTE) (BBQ).

MAGNESIUM WHITE (GLOSS) (WHT).

FRAME TRAIL SL 29'ER, OPTIMIZED 6061 ALLOY, SAVE

CRANKS SRAM S800 3.1, 44/33/22, 175MM (M,L,X)

BRAKES AVID ELIXIR 1, 160/160MM

FORK ROCKSHOX RECON SILVER TK 29, 80MM

DERAILLEURS, R/F SRAM X5 / X5

TIRES KENDA SMALL BLOCK 8, 2.1"

WHEELS MADDUX DC3.0 29'ER

SHIFTERS SRAM X5

SIZES S, M, L, X

> TRAIL 29'ER GEOMETRY

The Trail SL 29'er geometry features a slightly longer wheelbase and slacker head angle than the Flash 29'er for a stable, confidence-inspiring ride.

> SAVE COMFORT ENHANCING REAR STAYS

The chain stays and seat stays are designed to work together to absorb shock, while preventing side-to-side and twisting flex. This just adds to the inherent comfort of the larger wheels.

> 1.5" S/H HEAD TUBES

To improve stiffness, steering precision, and strength, all Trail SL 29'ers use forks with 1.5" steerer tubes. This subtle detail makes a big difference on the trail.



2FS293

TRAIL SL 29'ER 3

RACE RED (GLOSS) (RED).

VINTAGE MOSS (GLOSS) (GRN).

FRAME TRAIL SL 29'ER, OPTIMIZED 6061 ALLOY, SAVE

CRANKS SHIMANO FC-M430-8, 44/33/22, 175MM (M,L,X)

BRAKES SHIMANO M446, 160/160MM

FORK RST DEUCE COIL 29, 80MM

DERAILLEURS, R/F SHIMANO DEORE / ALIVIO

TIRES KENDA SMALL BLOCK 8, 2.1"

WHEELS MADDUX DC3.0 29'ER

SHIFTERS SHIMANO ALIVIO

SIZES S, M, L, X



2FS293R

TRAIL SL 29'ER 3R

JET BLACK (GLOSS) (BLK).

FRAME TRAIL SL 29'ER, OPTIMIZED 6061 ALLOY, SAVE

CRANKS TRUVATIV ISOFLOW 1.0G SS, 33T, 175MM (M,L,X)

BRAKES PROMAX MECHANICAL DISC, 160/160MM

FORK CANNONDALE FATTY RIGID 29'ER

DERAILLEURS, R/F N/A

TIRES KENDA SMALL BLOCK 8, 2.1"

WHEELS MADDUX DC3.0 29'ER

SHIFTERS N/A

SIZES S, M, L, X



2FS294

TRAIL SL 29'ER 4

JET BLACK (MATTE) (BLK).

SAFFRON METALLIC (MATTE) (ORG).

FRAME	TRAIL SL 29'ER, OPTIMIZED 6061 ALLOY, SAVE	CRANKS	SHIMANO M361, 42/32/22	BRAKES	CANNONDALE HELIX 3 HYDRAULIC DISC, 160/160MM
FORK	RST DEUCE 29 TNL, 80MM	DERAILLEURS, R/F	SHIMANO ALIVIO / ALTUS	TIRES	KENDA SMALL BLOCK 8, 2.1"
WHEELS	ALEX DC4.5 29'ER	SHIFTERS	SHIMANO ALTUS	SIZES	S, M, L, X



2FS295

TRAIL SL 29'ER 5

JET BLACK (GLOSS) (BLK).

MAGNESIUM WHITE (GLOSS) (WHT).

FRAME	TRAIL SL 29'ER, OPTIMIZED 6061 ALLOY, SAVE	CRANKS	SHIMANO M311, 42/32/22	BRAKES	PROMAX MECHANICAL DISC, 160/160MM
FORK	RST DEUCE 29 TNL, 80MM	DERAILLEURS, R/F	SHIMANO ACERA / ALTUS	TIRES	KENDA SMALL BLOCK 8, 2.1"
WHEELS	ALEX DC4.5 29'ER	SHIFTERS	SHIMANO ALTUS	SIZES	S, M, L, X

ADVOCACY

WHERE WOULD YOU RIDE IF THERE WAS NOWHERE TO RIDE?

We don't want to sound like your parents, but access and the ability to ride your bike reasonably safely doesn't grow on trees. If you want to ride your bike and enjoy its freedoms, you have to fight for it. You have to convince corporations, towns and cities to shed the car-only mentality and provide facilities and funding for two-wheeled, human-powered transport. This takes a lot of time, effort and resources.

Luckily, there are organizations out there whose sole purpose is to further the needs of cyclists. They exist to ensure that bikers get fair and equal representation, to lobby for alternate transport funding and to ensure that beautiful swaths of countryside remain open to pedal-powered pursuits.

Below, you'll find a few people who are fighting for us. Now is the time to help influence the direction of cycling as an alternate form of transport and recreation. Help support those who spend every waking moment creating more ways for all of us to enjoy our bicycles.

WE SUPPORT THESE ORGANIZATIONS, AND WE ASK YOU TO ASSIST TOO.



peopleforbikes.org

SUPPORTING PEOPLE FOR BIKES

Imagine one million people signing a petition in support of a better future for bicycling in the United States. We've partnered with People for Bikes to make that happen. By sending a unified message to our elected leaders, the media and the public, we can tell them that bicycling is important. With your help, we can ensure that our sport is properly promoted, funded and supported. More rider friendly communities, bike lanes and bike paths equal safety and fitness for all of us. Sign the pledge today at <http://www.peopleforbikes.org/>



SUPPORTING BIKES BELONG

We're supporting Bikes Belong and its mission to get more people riding bicycles. Since 1999, they've focused their efforts on advocating for more funding for new bicycle facilities that would increase bike riding, boost public health and strengthen the bike business. Their goal: creating safe places to ride so more people will bike, and bike more often. Learn more at <http://bikesbelong.org/>



SUPPORTING IMBA (INTERNATIONAL MOUNTAIN BIKE ASSOCIATION)

Cannondale's support of IMBA helps ensure that mountain bikers everywhere continue to have the land access rights, quality trails, and commitment to advocacy that makes the sport truly fun and enjoyable. Cannondale was one of the first sponsors of IMBA in 1991 and is proud to continue its support of the organization. What would you do without trails? <http://www.imba.com/>

@ridecannondale

facebook.com/ridecannondale

www.cannondale.com



RECREATION / URBAN

BAD BOY	72-75
QUICK CARBON / QUICK SL / QUICK	76-79
QUICK CX	80-81
ADVENTURE	82-84
ROAD TANDEM	84
HOOLOGAN	85

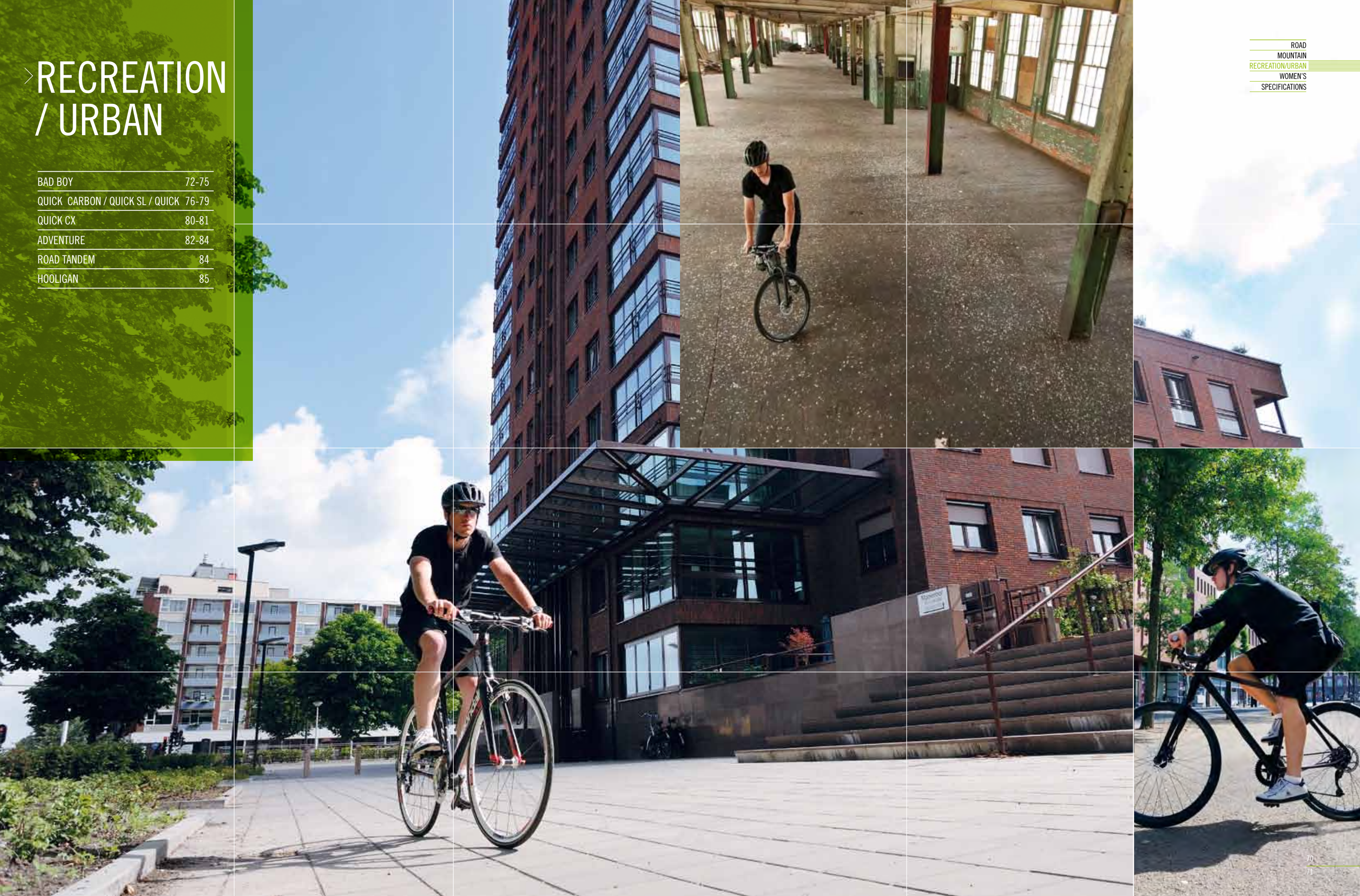

BAD BOY

URBAN. LEGEND.

URBAN MOBILITY WITH ATTITUDE. BAD BOY'S TRADEMARK MATTE BLACK LOOK, STEALTH-FIGHTER INSPIRED DESIGN AND RADICAL FORK OPTIONS MAKE AN UNDER-THE-RADAR STATEMENT UPTOWN, DOWNTOWN AND EVERYWHERE IN BETWEEN.

VICTORIES & AWARDS



2010 Eurobike Design Award



ROAD
MOUNTAIN
RECREATION/URBAN
WOMEN'S
SPECIFICATIONS



> UNIQUE FORK OPTIONS

To further personalize your own Bad Boy statement, chose from models with the sleek HeadShok DL50 with 50mm of travel, hydraulic damping and lockout, the radical single-legged Solo Rigid or the Fatty Rigid.



> EDGY STYLE

Bad Boy's trademark, understated matte black finish and hard-edged tube shapes look stylish and purposeful from any angle."



> INTEGRATED CONTROLS

Because Bad Boy is more than just a bike, we use our OPI technology to engineer a gorgeous, one-piece forged, integrated bar and stem for Bad Boy's cockpit.

2BS1 BAD BOY 1

FRAME	BAD BOY STEALTH, OPTIMIZED 6061 ALLOY	CRANKS	SHIMANO M431, BAD BOY, 48/36/26	STEM	CANNONDALE SI URBAN OPI STEM/HANDLEBAR
FORK	HEADSHOK SOLO DL50, 50 MM	DERAILLEURS R/F	SHIMANO SLX / DEORE	BRAKES	MAGURA MT2 HYDRAULIC DISC, 160/160 MM
TIRES	SCHWALBE KOJAK RACE GUARD, 700X28C	SHIFTERS	SHIMANO DEORE	SIZES	S, M, L, X

BLACK ANODIZED W/REFLECTIVE DECALS (MATTE) (BBQ)



2B85
BAD BOY 5

JET BLACK W/REFLECTIVE DECALS (MATTE) (BBQ)

FRAME	BAD BOY, OPTIMIZED 6061 ALLOY	CRANKS	SHIMANO M431, BAD BOY, 48/36/26	STEM	CANNONDALE SI URBAN OPI STEM/HANDLEBAR
FORK	CANNONDALE SOLO RIGID, OPI	DERAILLEURS R/F	SHIMANO DEORE / ALIVIO	BRAKES	SHIMANO M446 HYDRAULIC DISC, 160/160 MM
TIRES	SCHWALBE KOJAK RACE GUARD, 700X28C	SHIFTERS	SHIMANO ALIVIO	SIZES	S, M, L, X



2BF9
BAD BOY 9

JET BLACK W/ REFLECTIVE DECALS (MATTE) (BBQ)

FRAME	BAD BOY, OPTIMIZED 6061 ALLOY	CRANKS	SHIMANO M171, 48/38/28	STEM	CANNONDALE C4
FORK	CANNONDALE FATTY RIGID	DERAILLEURS R/F	SHIMANO ALIVIO / ALTUS	BRAKES	TEKTRO NOVELA MECHANICAL DISC, 160/160 MM
TIRES	SCHWALBE KOJAK RACE GUARD, 700X28C	SHIFTERS	SHIMANO M310 RAPIDFIRE PLUS	SIZES	S, M, L, X

ROAD
MOUNTAIN
RECREATION/URBAN
WOMEN'S
HELMETS
SPECIFICATIONS

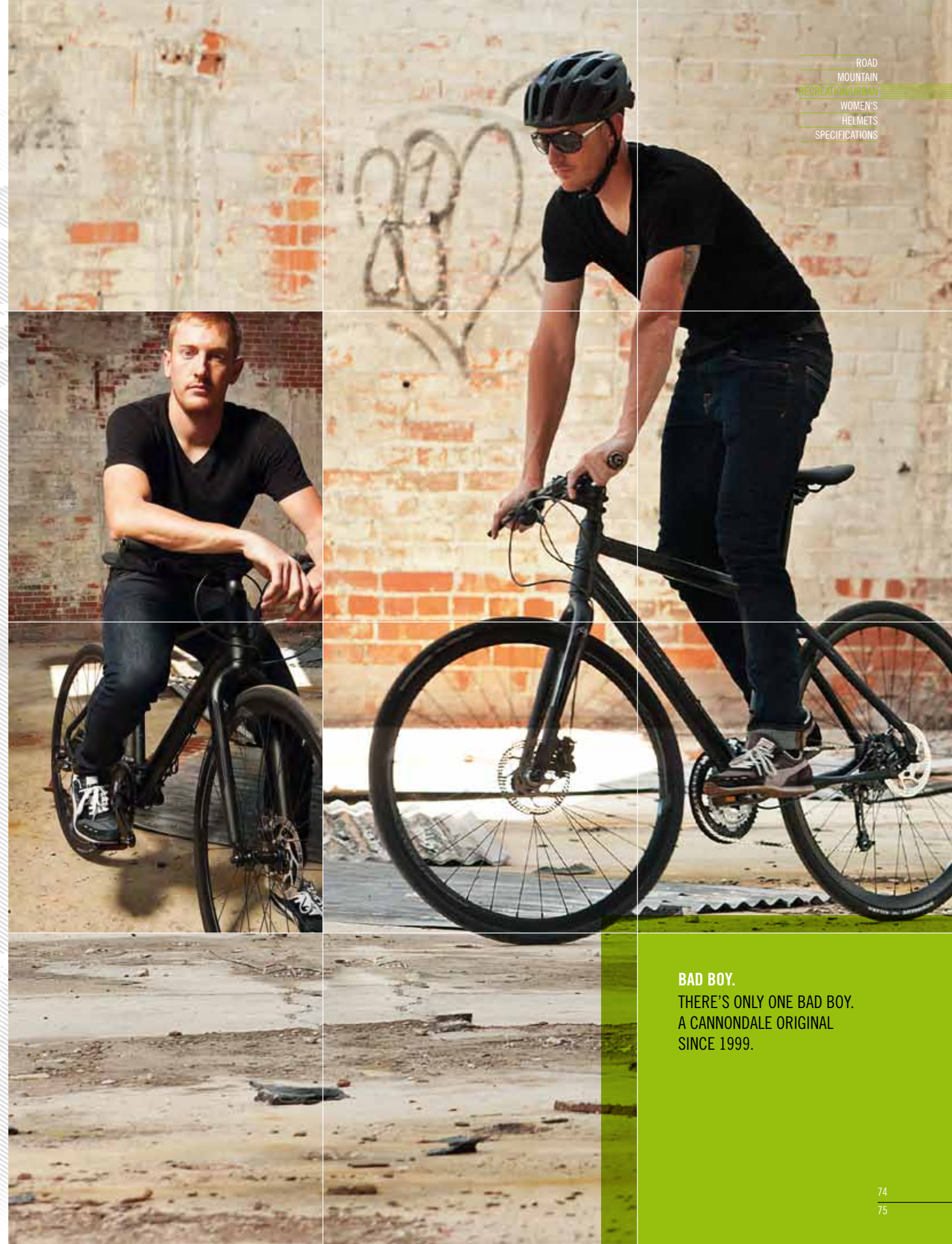

BAD BOY.
THERE'S ONLY ONE BAD BOY.
A CANNONDALE ORIGINAL
SINCE 1999.

QUICK

VELO. CITY.

QUICK IS A FAST AND NIMBLE FLAT BAR BIKE, PACKED WITH FEATURES LIKE *SAVE* VIBRATION DAMPING AND CARBON BLADED FORKS. WHETHER CRUISING THROUGH CENTRAL PARK OR COMPLETING THAT EPIC CHARITY RIDE, QUICK GETS IT DONE WITH STYLE AND FINESSE.



20RC1

QUICK CARBON 1

FRAME	QUICK FULL CARBON, SAVE
FORK	QUICK FULL CARBON SI
WHEELS	MAVIC KSYRIUM ELITE

TIRES	SCHWALBE MARATHON SUPREME, 700X28C
CRANKS	FSA SLK CARBON, BB30, 50/34
DERAILLEURS R/F	SHIMANO 6700

SHIFTERS	TIAGRA 4600, FLAT BAR
BRAKES	TEKTRO CX9 MINI V
SIZES	S, M, L, X, J

EXPOSED CARBON (MATTE) (CRB)

> ROAD BIKE SPEED, FLAT BAR COMFORT

Fast-rolling 700c wheels paired with an upright riding position gives you the best of both worlds – a speedy, fun package with great comfort and worry-free visibility.

> *SAVE* VIBRATION DAMPING STAYS

Optimized chain stay and seat stay shaping provides bump absorption, comfort and enhanced control with no loss in power transfer.

> LIGHT AND STYLISH

Whether the Quick, the lighter weight Quick SL, or the radical Quick Carbon, these sleekly-styled frames are the lightest in class, making the bike nimble, responsive and a breeze to carry up stairs.



20RC2

QUICK CARBON 2

FRAME	QUICK FULL CARBON, SAVE
FORK	QUICK FULL CARBON SI
WHEELS	ELEMENT C3

TIRES	KENDA KWICK, 700X28C
CRANKS	FSA OMEGA, BB30, 50/34
DERAILLEURS R/F	SRAM APEX

SHIFTERS	SRAM X5
BRAKES	CANNONDALE MINI V
SIZES	S, M, L, X, J

EXPOSED CARBON (MATTE) (CRB)



20R1

QUICK SL 1

FRAME	QUICK SL, OPTIMIZED 6061 ALLOY, SAVE
FORK	QUICK, CARBON BLADES
WHEELS	ELEMENT C2

TIRES	CONTINENTAL SPORT CONTACT, 700X32C
CRANKS	SHIMANO 105 5700, 50/39/30
DERAILLEURS R/F	SHIMANO 105 5700 / R773

SHIFTERS	SHIMANO TIAGRA 4600 FLATBAR
BRAKES	CANNONDALE C2 MINI V
SIZES	S, M, L, X, J

BRUSHED ALUMINUM (GLOSS) (RAW)



2QR2
QUICK SL 2 JET BLACK (GLOSS) (BLK)

FRAME	QUICK SL, OPTIMIZED 6061 ALLOY, SAVE	TIRES	CONTINENTAL SPORT CONTACT, 700X32C (26X1.3" ON XS)	SHIFTERS	SHIMANO R440, RAPIDFIRE PLUS
FORK	QUICK, CARBON BLADES	CRANKS	SHIMANO SORA, 50/39/30	BRAKES	CANNONDALE C2 MINI V
WHEELS	ELEMENT C3 - 700C (26" ON XS)	DERAILLEURS R/F	SHIMANO SORA / R443	SIZES	XS, S, M, L, X, J



2QR4
QUICK 4 JET BLACK (GLOSS) (BLK) CHARCOAL GREY (GLOSS) (GRV)

FRAME	QUICK, BUTTED 6061 ALLOY, SAVE	TIRES	KENDA KWICK TRAX, 700X32C (26X1.5" ON XS)	SHIFTERS	SHIMANO M310 RAPIDFIRE PLUS
FORK	QUICK, CARBON BLADES	CRANKS	SHIMANO M171, 48/38/28	BRAKES	CANNONDALE C4 MINI V
WHEELS	ELEMENT C3 - 700C (26" ON XS)	DERAILLEURS R/F	SHIMANO ALIVIO / M191	SIZES	XS, S, M, L, X, J



2QR3
QUICK 3 INDIGO BLUE (GLOSS) (BLU) MAGNESIUM WHITE (GLOSS) (WHT)

FRAME	QUICK, BUTTED 6061 ALLOY, SAVE	TIRES	CONTINENTAL CITY CONTACT, 700X32C	SHIFTERS	SHIMANO ALIVIO RAPIDFIRE PLUS
FORK	QUICK, CARBON BLADES	CRANKS	SHIMANO M431, 48/36/26	BRAKES	CANNONDALE C3 MINI V
WHEELS	ELEMENT C3	DERAILLEURS R/F	SHIMANO DEORE / ALIVIO	SIZES	S, M, L, X, J



2QR5
QUICK 5 FINE SILVER (GLOSS) (SLV)

FRAME	QUICK, BUTTED 6061 ALLOY, SAVE	TIRES	KENDA KWICK TRAX, 700X32C	SHIFTERS	SHIMANO M310 RAPIDFIRE PLUS
FORK	QUICK, 6061 ALLOY	CRANKS	SHIMANO M131, 48/38/28	BRAKES	CANNONDALE C4 MINI V
WHEELS	CANNONDALE C4	DERAILLEURS R/F	SHIMANO ALTUS / M191	SIZES	S, M, L, X, J

QUICK CX

SPORT. UTILITY.

COMBINING THE STABILITY AND STRENGTH OF A MOUNTAIN BIKE WITH THE NIMBLENESS AND LIGHT WEIGHT OF A CITY BIKE, THE QUICK CX IS THE PERFECT ADVENTURE PARTNER.



20RX1

QUICK CX 1

FRAME	QUICK CX, OPTIMIZED 6061 ALLOY, SAVE
FORK	HEADSHOK FATTY DL50, 50 MM
WHEELS	MADDUX DC3.0

TIRES	CONTINENTAL DOUBLE FIGHTER II, 700X37C
CRANKS	SHIMANO M521, 48/36/26
DERAILLEURS R/F	SHIMANO SLX / ALIVIO

SHIFTERS	SHIMANO DEORE
BRAKES	SHIMANO M505 HYDRAULIC DISC, 160/160MM
SIZES	S, M, L, X, J

BRUSHED ALUMINUM (GLOSS) (RAW)

TRAVEL IN STYLE

With sleek, functional tube shapes, oversized head tubes, and suspension forks on most models, the Quick CX makes a statement on the city streets but is up to the challenges of excursions on rougher roads and bike trails.

SAVE VIBRATION DAMPING STAYS

Optimized rear stay shaping provides bump absorption, comfort and enhanced control with no loss in power transfer.

HEADS-UP RIDING

The Quick CX geometry delivers an upright, stable riding position for increased comfort, visibility and enjoyment. Relax and enjoy the ride.



20RX2

QUICK CX 2

JET BLACK (GLOSS) (BLK)

FRAME	QUICK CX, OPTIMIZED 6061 ALLOY, SAVE
FORK	RST NEON PRO TREKKING TNL, 50MM
WHEELS	MADDUX DC3.0

TIRES	CONTINENTAL DOUBLE FIGHTER II, 700X37C
CRANKS	SHIMANO M431, 48/36/26
DERAILLEURS R/F	SHIMANO DEORE / ALIVIO

SHIFTERS	SHIMANO ALIVIO
BRAKES	SHIMANO M446 HYDRAULIC DISC, 160/160 MM
SIZES	S, M, L, X, J



20RX3

QUICK CX 3

MAGNESIUM WHITE (GLOSS) (WHT)

FRAME	QUICK CX, OPTIMIZED 6061 ALLOY, SAVE
FORK	RST NEON PRO TREKKING ML, 50MM
WHEELS	MADDUX TC 5.0

TIRES	CONTINENTAL DOUBLE FIGHTER II, 700X37C
CRANKS	SHIMANO M171, 48/38/28
DERAILLEURS R/F	SHIMANO ALIVIO / M191

SHIFTERS	SHIMANO ACERA
BRAKES	TEKTRO NOVELA MECHANICAL DISC, 160/160 MM
SIZES	S, M, L, X, J



20RX4

QUICK CX 4

JET BLACK (GLOSS) (BLK)

FRAME	QUICK CX RIGID, OPTIMIZED 6061 ALLOY, SAVE
FORK	FATTY RIGID DISC
WHEELS	MADDUX DC3.0

TIRES	CONTINENTAL DOUBLE FIGHTER II, 700X37C
CRANKS	SHIMANO M171 48/38/28
DERAILLEURS R/F	SHIMANO ACERA / M191

SHIFTERS	SHIMANO ALTUS
BRAKES	TEKTRO NOVELA MECHANICAL DISC, 160/160 MM
SIZES	S, M, L, X, J

ADVENTURE

EASY. RIDER.

ADVENTURE IS THE PERFECT BIKE FOR THE RECREATIONAL CYCLIST. COMMUTING TO WORK ONE DAY, RUNNING ERRANDS THE NEXT, BIKING WITH THE KIDS OR TAKING A SPIN ON A WEEKEND GETAWAY, ADVENTURE IS READY TO HANDLE IT ALL.



2AS2

ADVENTURE 2

JET BLACK (GLOSS) (BLK)

FRAME ADVENTURE, DOUBLE BUTTED 6061 ALLOY

DERAILLEURS, R/F SHIMANO ALIVIO / M191

SADDLE CANNONDALE ULTRA COMFORT

FORK ADVENTURE TRAIL SI SUSPENSION, 35MM

BRAKE LEVERS CANNONDALE, 4 FINGER W/KRATON COMFORT INSERT

SEATPOST CANNONDALE SUSPENSION, 40MM TRAVEL

SHIFTERS SHIMANO REVO TWIST TYPE

TIRES KENDA KWICK TRAX, 700 X 38C

SIZES S, M, L, X, J

> RIDER-TAILORED GEOMETRY

For maximum comfort and confidence, Adventure has our most upright rider position and a seat angle that permits the rider to comfortably touch the ground, without compromising the ability to pedal efficiently.

> LUXURIOUS TRAPPINGS

Soft touch material on the grips and quick-release levers, combined with a super plush spring saddle gives the Adventure a luxurious feel.

> TOOL-FREE STEM ADJUSTMENT

Rider position is quickly and easily customizable with a secure, lever-action adjustable stem.



2AS3

ADVENTURE 3

INDIGO BLUE (GLOSS) (BLU)

FRAME ADVENTURE, DOUBLE BUTTED 6061 ALLOY

DERAILLEURS, R/F SHIMANO ACERA / M191

SADDLE CANNONDALE ULTRA COMFORT

FORK RST SOFI T, 50MM

BRAKE LEVERS CANNONDALE, 4 FINGER W/KRATON COMFORT INSERT

SEATPOST CANNONDALE SUSPENSION, 40MM TRAVEL

SHIFTERS SHIMANO REVO TWIST TYPE

TIRES KENDA KWICK TRAX, 700 X 38C

SIZES S, M, L, X, J



2CS3

ADVENTURE 3 26"

INDIGO BLUE (GLOSS) (BLU)

FRAME ADVENTURE 26", DOUBLE BUTTED 6061 ALLOY

DERAILLEURS, R/F SHIMANO ACERA / M191

SADDLE CANNONDALE ULTRA COMFORT

FORK RST SOFI T 26", 50MM

BRAKE LEVERS CANNONDALE, 4 FINGER W/KRATON COMFORT INSERT

SEATPOST CANNONDALE SUSPENSION, 40MM TRAVEL

SHIFTERS SHIMANO REVO TWIST TYPE

TIRES KENDA K1052, 26 X 2.1"

SIZES S, M, L, X, J

TANDEM

FAST. COMPANY.

COMBINE THE POWER OF TWO WITH THE AERO PROFILE OF ONE. COMBINE PEOPLE OF DIFFERING ABILITIES. THE CANNONDALE TANDEM CHANNELS THE POWER OF TWO INTO ONE SWEET, SYNCHRONIZED WHOOSH OF SPEED AND THRILLS. LIKE PEANUT BUTTER AND JELLY, BUT FASTER.



9R12
ROAD TANDEM

LIGHTNING WHITE (GLOSS) (WHT)

FRAME	CAAD TANDEM, OPTIMIZED 6061 ALLOY, 700C	CRANK	FSA GOSSAMER TANDEM, 53/39/30	BRAKES	AVID BB7 ROAD DISC
FORK	FATTY R TANDEM RIGID	DERAILLEURS	SHIMANO ULTEGRA 6700, 10-SPEED	SADDLE	FIZIK ALIANTE DELTA MG
WHEELS	SUN ME14A W/EYELET AND MACHINED SIDEWALL	SHIFTERS	SHIMANO ULTEGRA 6700	SIZES	MS, LS, XS, JM

HOOLIGAN

JUNGLE. GYM.

WITH ITS COMPACT 20" WHEELS, STOUT FRAME AND LOW STANDOVER, THE HOOLIGAN BALANCES FUNCTIONAL SENSIBILITY WITH FRIVOLOUS FUN. PERFECT FOR THE CHALLENGES OF CITY LIFE, HOOLIGAN MAKES PRACTICALITY LOOK GOOD.



2HL1
HOOLIGAN

BERSERKER GREEN (GLOSS) (GRN) STEALTH GREY (GLOSS) (GRY)

FRAME	NEW HOOLIGAN DELTA V, URBAN COMPACT	CRANKS	FSA VERO, SINGLE RING, DUAL ALLOY CHAINGUARD, 48T	STEM	CANNONDALE C3
FORK	CANNONDALE SOLO RIGID, OPI	DERAILLEURS R/F	SHIMANO NEXUS REVO 3-SPEED	BRAKES	SHIMANO M375 MECHANICAL DISC, 160/160 MM
TIRES	KENDA QUEST, 20 X 1.5"	SHIFTERS	SHIMANO NEXUS REVO 3-SPEED	SIZES	ONE SIZE

ROAD
MOUNTAIN
RECREATION/URBAN
WOMEN'S
SPECIFICATIONS

> LIGHTEST AND STIFFEST

It's the lightest, most torsionally rigid tandem on the market. No nervous flex when powering out of saddle. Responsive handling and sure-footed stability when bombing the descents. Pure speed. Pure confidence. Pure performance.

> OPTIMIZED COCKPITS

A taller head tube and shorter top tube give the captain better control and more comfort, while the stoker gets increased standover clearance for easier starts and stops.

> CANNONDALE ALUMINUM

A structure as long and complex as a tandem is the perfect showcase for our aluminum skills. The box section **Boom Tube**, oversized chain stays, disc brake dropouts and smooth welds demonstrate our expertise.

> ONE SIZE FITS ALL

Lower standover, a custom 520mm seatpost and an adjustable stem lets the Hooligan fit all sizes of rider and all styles of riding - from low and aggressive to upright and comfy.

> DELTA V

The **Delta V** frame configuration is light and gorilla-strong, and its excellent standover gives the rider plenty of clearance for agile street moves.

> SLIDE 2GO® ACCESSORY MOUNTING BRACKET

The Hooligan features a convenient, secure, **System Integrated** head tube mounting point for **Slide 2GO** accessories.

KEY TECHNOLOGIES

SAVE MICRO-SUSPENSION TECHNOLOGY

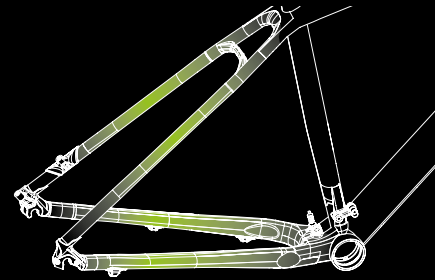

SAVE MICRO-SUSPENSION TECHNOLOGY

MORE COMFORT. MORE SPEED.

SAVE Micro-Suspension Technology is our series of four ride-tuned micro suspension systems designed to reduce road shock and vibration. Through the use of sophisticated carbon layups and highly-manipulated aluminum we create areas on the rear chainstays and seatstays, fork blades or seatpost that resist side-to-side forces while absorbing vertical forces. This translates into reduced fatigue and increased comfort, letting you ride longer and ride faster.

SPEED SAVE RACE-FOCUSED

Like the suspension on F1 cars, SPEED SAVE features are engineered to make the bike faster, not just more comfortable. Emphasizing light weight and torsional rigidity, SPEED SAVE delivers improved rolling speed, better acceleration, and faster cornering speeds without affecting power transfer. Found on SuperSix EVO, CAAD10, SuperX and Flash models

SAVE PLUS COMFORT-RACE

SAVE PLUS offers even more shock absorption and rider protection than SPEED SAVE. Perfect for carrying top speed over the cobbles of northern Europe or for smoothing out your next Gran Fondo. Found on Synapse Carbon and Synapse Alloy.

AERO SAVE AERODYNAMIC

AERO SAVE mates energy saving shock absorption with slippery aerodynamic shapes. By absorbing the jarring vibrations of the road, AERO SAVE allows you to stay in the aero position longer, stay in better control over rough surfaces, and come off the bike fresher for the run. Chrissie Wellington's secret weapon. Found on Slice.

SAVE EVERYDAY, MIXED-SURFACE RIDING

Simple and effective SAVE features, engineered to protect you from energy-sapping vibration. SAVE will smooth out your ride, whether dropping off a curb, dodging obstacles on city streets or hopping logs off-road. Found on Quick, Bad Boy, Bad Girl, Trail, CAAD8 and Tesoro.

ECS-TC (ENHANCED CENTER STIFFNESS – TORSION CONTROL) SYSTEM

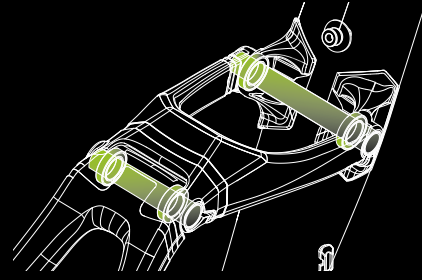

ECS-TC (ENHANCED CENTER STIFFNESS – TORSION CONTROL) SYSTEM

A frame is only as stiff as its weakest parts. On dual suspension bikes, those weakest parts are often the crucial bearings and links that join the swingarm to the front triangle. The vague, imprecise sensation felt on so many bikes is caused by the subtle movement and flex that occurs in the connecting hardware as the loads on the bike shift from side-to-side. Individual cartridge bearings all exhibit slight lateral play as the races shift and begin loading the bearings. Links and axles often flex and rotate relative to each other, and these small factors all combine to negatively influence what we call Center Stiffness. To create bikes with solid Center Stiffness, which respond instantly to rider input and deliver unprecedented sensitivity and feedback, we designed a multi-part system, eliminating any flex and play in the links and bearings.

DOUBLE CLAMPED 15MM THRU-AXLES

The ECS-TC system uses 15mm thru-axles for the key pivots. By placing axle bearings in-board and clamping the ends of the axle, the axle becomes a structural part of the link or swingarm. Tying the two sides of the link or swingarm together via the axle in this manner radically increases the system's ability to resist twisting loads.

ULTRA-WIDE BEARING PLACEMENT

Just like you are more stable standing with your feet apart than together, the further apart you can place cartridge bearings, the better they can support each other and the stiffer the system can be. ECS-TC systems always space the bearings as widely as possible.

DOUBLE-STACKED REAR DROPOUT PIVOT BEARINGS

At the rear dropout, where the wheel prevents the two pivots from being joined by an axle, we double-stack two bearings side by side in each pivot. This greatly increases the seat stays ability to instantly resist twisting loads, making for an incredibly solid feeling swingarm.

COLLET SLEEVE BEARING PRELOAD

Rather than rely on spacers or washer to take up the space between the links and bearings like other systems, the ECS-TC system has an innovative collet-style preload system. Sitting between the clamp and the axle, the collet sleeves slide into place against the bearing, eliminating any play and allowing perfect centering of the link.

SMARTFORMED ALLOY

The distilled result of three decades of accumulated aluminum construction experience, SmartForming techniques deliver incredibly precise wall thickness distribution and tube shapes, concentrating material exactly where needed to maximize stiffness and strength, while shaving every last extraneous gram from the structure. Internally, all butting is accomplished via smooth, tapered transitions to eliminate the abrupt changes in material thickness which cause stress-risers.

Unlike the putty-and-paint "smooth" welds of our competition, Cannondale's legendary double-pass smooth welds create the strongest possible joints. Combined with our post-weld, heat-treat process that creates an true uni-body finished structure, and you've got simply the most advanced aluminum frames.

DYAD RT2 DUAL SHOCK

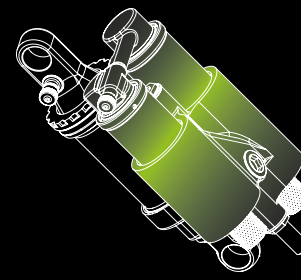

DYAD RT2 DUAL SHOCK

Developed in collaboration with Cannondale, the dual-travel, dual-personality FOX DYAD RT2 is actually two completely different shocks housed in one package: Elevate – a shorter travel, smaller volume air shock for rolling and climbing terrain, and Flow – a longer travel, high volume linear air shock for aggressive descending. Activated by a handlebar-mounted lever, each mode has its own dedicated damping circuits, fully optimized for the intended terrain. Rather than try to make one shock handle everything, we were free to create separate suspension responses for different needs – active and super efficient for the flats and climbs, ultra plush and bottomless for the descents.

Switching between the Elevate and Flow modes also changes the bike's sag point and geometry, a feature we call Attitude Adjust Geometry. In Elevate mode, the bike rides higher, resulting in steeper head and seat angles and keeping the rider in a better position for climbing and tight technical terrain. In Flow mode, the BB drops, lowering the center of gravity and making the angles slack and stable, perfect for charging descents.

With the DYAD RT2, it fundamentally is like having two different bikes available to you at the flick of a switch. Elevate your soul and let it Flow.

ZERO PIVOT TECHNOLOGY

Zero Pivot technology does just what the name implies – it eliminates traditional bearing pivots, and replaces them with flexing carbon fiber structures, which is actually not as crazy as it sounds. Done correctly, a flexing carbon structure can be designed to last a virtually infinite number of cycles, while eliminating the weight, play and

ZERO PIVOT TECHNOLOGY

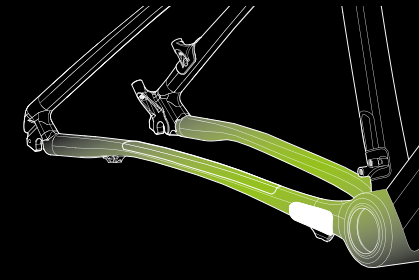

wear of bearing connections. We have developed proprietary carbon construction techniques that enable the Zero Pivot stays flex freely in one direction only, while actually resisting side-to-side and twisting loads better than a bearing pivot can. Zero Pivot is what allows the Scalpel to be not only the lightest dual suspension frame in the world, but to also have the best stiffness-to-weight ever recorded.

OPI (ONE PIECE INTEGRATION)

Cannondale's patented 3D forging process allows us to take structures that would ordinarily consist of multiple pieces that would be bolted, bonded, welded or otherwise joined together and turn them into single-piece forged parts. By forging the pieces from a single block of aluminum, we end up with exceptionally good grain alignment, which makes the parts stronger, and we eliminate excess, overlapping or redundant material, which makes them lighter. This technology makes parts like the Lefty OPI outer tube/clamp structure, the Lefty OPI inner leg/axle, the OPI one-piece stem/steerer and the Backbone of the RZ120 possible.

BALLISTEC CARBON

Our High Strength, High-Impact Carbon technology. We begin with a type of carbon fiber created by the military for ballistic armoring. It's expensive, rare, and government controlled; to prevent it from falling into the wrong hands and being used militarily, we have to sign documents that account for the use of every kilogram of fibers we buy. This is some seriously tough stuff. The resins we use are High Strength, High Impact resins similar to what is used in the construction of carbon baseball bats; light, stiff and designed to endure thousands of deformation cycles. We combine these fibers and this resin in a lay-up designed to maximize the anisotropic (direction-

OPI (ONE PIECE INTEGRATION)

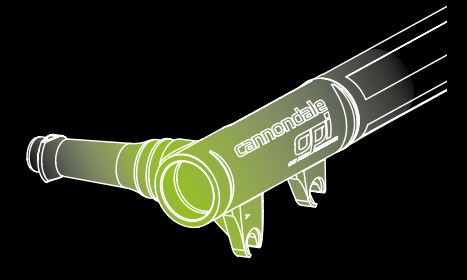

specific) qualities of the fibers, providing a carbon structure that is extremely light, extremely stiff and capable of absorbing tremendous impact without damage or loss of structural integrity.

Only once the frame has passed all of our extremely tough destructive and fatigue testing do we go back and begin adding the stiffer, but more brittle high-modulus and ultra-high modulus fibers strategically simply to enhance stiffness and tune the ride-feel. By using these more brittle fibers in protected areas and solely to add stiffness, without relying on them for strength, we can create super-light, super-stiff frames that are also incredibly durable and safe. And because the entire frame is made from this tough, durable combination, it offers better overall durability relying on carbon shields or overbuilt sections.

ROAD SPECIFICATIONS

	SUPERSIX EVO ULTIMATE
CODE	2RSEUD
FRAME	SUPERSIX EVO, BALLISTEC HI-MOD CARBON, SPEED SAVE, PRESSFIT BB30
FORK	SUPERSIX EVO, SPEED SAVE, BALLISTEC HI-MOD FULL CARBON, 1-1/8" TO 1-1/4" STEERER
RIMS	DT SWISS, RRC425F FRONT, RRC525R REAR, CARBON TUBULARS
HUBS	DT SWISS, RRC425F FRONT, RRC525R REAR
SPOKES	DT SWISS, STAINLESS, BUTTED, BLADED
TIRES	SCHWALBE ULTREMO TUBULAR LIGHT, 700X23C
PEDALS	N/A
CRANK	CANNONDALE HOLLOWGRAM SL, BB30, SI RINGS, 53/39 (50/34 RINGS AND SPIDER INCLUDED)
BOTTOM BRACKET	SRAM PRESSFIT BB30, CERAMIC BEARINGS
CHAIN	SRAM PC-1091R
REAR COGS	SRAM RED, 11-26, 10-SPEED
FR. DERAILLEUR	SRAM RED, BRAZE-ON
REAR DERAILLEUR	SRAM RED
SHIFTERS	SRAM RED
HANDLEBAR	ZIPP SL
GRIPS	FI'ZIK BAR TAPE
STEM	FSA OS-99, ULTIMATE EDITION, 31.8, 6 DEG
HEADSET	SUPERSIX EVO, 1-1/4" LOWER BEARING, 25MM CARBON TOP COVER (W/5MM ALLOY HIDDEN TOP COVER)
BRAKES	TRP 970SL
BRAKE LEVERS	SRAM RED
SADDLE	FI'ZIK ANTARES 00, WING FLEX, CARBON RAILS
SEATPOST	USE ALIEN CYCLOPS CARBON, 27.2X270MM
SIZES	48, 50, 52, 54, 56, 58, 60, 63CM
COLOR 1 (CODE)	EXPOSED CARBON W/OUTLINE DECALS (MATTE) (ULT)
COLOR 2 (CODE)	N/A
EXTRAS	INCLUDES BOTH STANDARD AND COMPACT CHAINRINGS AND SPIDERS, TUNE GR, TUNE WATERBOTTLE BOLTS

	SUPERSIX EVO TEAM
CODE	2RSEOD
FRAME	SUPERSIX EVO, BALLISTEC HI-MOD CARBON, SPEED SAVE, PRESSFIT BB30
FORK	SUPERSIX EVO, SPEED SAVE, BALLISTEC HI-MOD FULL CARBON, 1-1/8" TO 1-1/4" STEERER
RIMS	MAVIC COSMIC CARBONE SLR
HUBS	MAVIC COSMIC CARBONE SLR
SPOKES	MAVIC COSMIC CARBONE SLR
TIRES	MAVIC YKSION, GRIPLINK FRONT AND POWERLINK REAR, 700X23C, FOLDING
PEDALS	N/A
CRANK	CANNONDALE HOLLOWGRAM SL, BB30, SRAM RED RINGS, 53/39 (50/34 RINGS AND SPIDER INCLUDED)
BOTTOM BRACKET	SRAM PRESSFIT BB30, CERAMIC BEARINGS
CHAIN	SRAM PC-1091R
REAR COGS	SRAM RED, 11-26, 10-SPEED
FR. DERAILLEUR	SRAM RED, BRAZE-ON
REAR DERAILLEUR	SRAM RED
SHIFTERS	SRAM RED
HANDLEBAR	FSA K-FORCE CARBON NANO
GRIPS	FI'ZIK BAR TAPE
STEM	FSA K-FORCE CARBON, 31.8, 6 DEG
HEADSET	SUPERSIX EVO, 1-1/4" LOWER BEARING, 25MM CARBON TOP COVER (W/5MM ALLOY HIDDEN TOP COVER)
BRAKES	SRAM RED
BRAKE LEVERS	SRAM RED
SADDLE	FI'ZIK ANTARES, BRAIDED CARBON RAILS
SEATPOST	FSA K-FORCE CARBON, 27.2X250MM
SIZES	48, 50, 52, 54, 56, 58, 60, 63CM
COLOR 1 (CODE)	LIQUIGAS TEAM REPLICA (GLOSS) (LIQ)
COLOR 2 (CODE)	N/A
EXTRAS	INCLUDES BOTH STANDARD AND COMPACT CHAINRINGS AND SPIDERS

	SUPERSIX EVO D12
CODE	2RSEID
FRAME	SUPERSIX EVO, D12 SPECIFIC, BALLISTEC HI-MOD CARBON, SPEED SAVE, PRESSFIT BB30
FORK	SUPERSIX EVO, SPEED SAVE, BALLISTEC HI-MOD FULL CARBON, 1-1/8" TO 1-1/4" STEERER
RIMS	MAVIC KSYRIUM SLR
HUBS	MAVIC KSYRIUM SLR
SPOKES	MAVIC KSYRIUM SLR
TIRES	MAVIC YKSION, GRIPLINK FRONT AND POWERLINK REAR, 700X23C, FOLDING
PEDALS	N/A
CRANK	CANNONDALE HOLLOWGRAM SL, BB30, FSA DA79 RINGS, 53/39 (50/34 RINGS AND SPIDER INCLUDED)
BOTTOM BRACKET	FSA PRESSFIT BB30, CERAMIC BEARINGS
CHAIN	SHIMANO DURA-ACE 7900
REAR COGS	SHIMANO DURA-ACE 7900, 12-25, 10-SPEED
FR. DERAILLEUR	SHIMANO DURA-ACE D12, BRAZE-ON
REAR DERAILLEUR	SHIMANO DURA-ACE D12
SHIFTERS	SHIMANO DURA-ACE D12
HANDLEBAR	FSA K-FORCE CARBON COMPACT
GRIPS	FI'ZIK BAR TAPE
STEM	FSA OS-99 CSI, 31.8, 6 DEG
HEADSET	SUPERSIX EVO, 1-1/4" LOWER BEARING, 25MM CARBON TOP COVER (W/ 5MM ALLOY HIDDEN TOP COVER)
BRAKES	SHIMANO DURA-ACE 7900
BRAKE LEVERS	SHIMANO DURA-ACE D12
SADDLE	FI'ZIK ANTARES, KIJUM RAILS
SEATPOST	FSA K-FORCE CARBON, 27.2X250MM
SIZES	50, 52, 54, 56, 58, 60 CM
COLOR 1 (CODE)	EXPOSED CARBON W/ CHARCOAL GRAY, WHITE, RED (MATTE) (CRB)
COLOR 2 (CODE)	N/A
EXTRAS	INCLUDES BOTH STANDARD AND COMPACT CHAINRINGS AND SPIDERS

	SUPERSIX EVO 1 DURA-ACE
CODE	2RSEID
FRAME	SUPERSIX EVO, BALLISTEC HI-MOD CARBON, SPEED SAVE, PRESSFIT BB30
FORK	SUPERSIX EVO, SPEED SAVE, BALLISTEC HI-MOD FULL CARBON, 1-1/8" TO 1-1/4" STEERER
RIMS	MAVIC KSYRIUM SL
HUBS	MAVIC KSYRIUM SL
SPOKES	MAVIC KSYRIUM SL
TIRES	SCHWALBE ULTREMO ZX, 700X23C
PEDALS	N/A
CRANK	CANNONDALE HOLLOWGRAM SL, BB30, FSA DA79 RINGS, 53/39 (50/34 RINGS AND SPIDER INCLUDED)
BOTTOM BRACKET	FSA PRESSFIT BB30, CERAMIC BEARINGS
CHAIN	SHIMANO DURA-ACE 7900
REAR COGS	SHIMANO DURA-ACE 7900, 12-25, 10-SPEED
FR. DERAILLEUR	SHIMANO DURA-ACE 7900, BRAZE-ON
REAR DERAILLEUR	SHIMANO DURA-ACE 7900
SHIFTERS	SHIMANO DURA-ACE 7900
HANDLEBAR	FSA K-FORCE CARBON COMPACT
GRIPS	FI'ZIK BAR TAPE
STEM	FSA OS-99 CSI, 31.8, 6 DEG
HEADSET	SUPERSIX EVO, 1-1/4" LOWER BEARING, 25MM CARBON TOP COVER (W/5MM ALLOY HIDDEN TOP COVER)
BRAKES	SHIMANO DURA-ACE 7900
BRAKE LEVERS	SHIMANO DURA-ACE 7900
SADDLE	FI'ZIK ANTARES, KIJUM RAILS
SEATPOST	FSA K-FORCE CARBON, 27.2X250MM
SIZES	48, 50, 52, 54, 56, 58, 60, 63CM
COLOR 1 (CODE)	MAGNESIUM WHITE W/JET BLACK (GLOSS) (WHT)
COLOR 2 (CODE)	
EXTRAS	INCLUDES BOTH STANDARD AND COMPACT CHAINRINGS AND SPIDERS

	SUPERSIX EVO 2 SRAM RED
CODE	2RSE2D, 2RSE2C
FRAME	SUPERSIX EVO, BALLISTEC HI-MOD CARBON, SPEED SAVE, PRESSFIT BB30
FORK	SUPERSIX EVO, SPEED SAVE, BALLISTEC HI-MOD FULL CARBON, 1-1/8" TO 1-1/4" STEERER
RIMS	MAVIC KSYRIUM ELITE
HUBS	MAVIC KSYRIUM ELITE
SPOKES	MAVIC KSYRIUM ELITE
TIRES	SCHWALBE ULTREMO ZX, 700X23C
PEDALS	N/A
CRANK	SRAM RED W/CANNONDALE GRAPHICS, BB30, 53/39 (OPTION: 50/34 COMPACT)
BOTTOM BRACKET	SRAM PRESSFIT BB30
CHAIN	SHIMANO ULTEGRA 6700
REAR COGS	SHIMANO ULTEGRA 6700, 12-25, 10-SPEED
FR. DERAILLEUR	SHIMANO DURA-ACE 7900, BRAZE-ON
REAR DERAILLEUR	SHIMANO DURA-ACE 7900
SHIFTERS	SHIMANO DURA-ACE 7900
HANDLEBAR	CANNONDALE C2 COMPACT, 2014 DOUBLE BUTTED ALLOY
GRIPS	CANNONDALE 2.5MM SUEDE W/GEL BACKING BAR TAPE
STEM	CANNONDALE C2, 2014 3D FORGED ALLOY, 31.8MM, 6 DEG.
HEADSET	CAAD10, 1-1/4" LOWER BEARING, 25MM CARBON TOP CAP
BRAKES	SHIMANO ULTEGRA 6700
BRAKE LEVERS	SHIMANO DURA-ACE 7900
SADDLE	PROLOGO SCRATCH
SEATPOST	CANNONDALE C2, UD CARBON, 27.2X300MM
SIZES	48, 50, 52, 54, 56, 58, 60, 63CM
COLOR 1 (CODE)	BLACK ANODIZED (MATTE) (BLA)
COLOR 2 (CODE)	MAGNESIUM WHITE W/JET BLACK (GLOSS) (WHT)

ROAD SPECIFICATIONS

	CAAD10 1 DURA-ACE
CODE	2RAX1D, 2RAX1C
FRAME	CAAD10, SMARTFORMED 6069 ALLOY, SPEED SAVE, BB30
FORK	CAAD10, SPEED SAVE FULL CARBON, 1-1/8" TO 1-1/4" TAPERED STEERER
RIMS	SHIMANO RS80
HUBS	SHIMANO RS80
SPOKES	SHIMANO RS80
TIRES	SCHWALBE DURANO S, 700X23C, FOLDING
PEDALS	N/A
CRANK	FSA SL-K LIGHT CARBON, BB30, 53/39 (OPTION: COMPACT 50/34)
BOTTOM BRACKET	FSA BB30
CHAIN	SHIMANO ULTEGRA 6700
REAR COGS	SHIMANO ULTEGRA 6700, 12-25, 10-SPEED
FR. DERAILLEUR	SHIMANO DURA-ACE 7900, BRAZE-ON
REAR DERAILLEUR	SHIMANO DURA-ACE 7900
SHIFTERS	SHIMANO DURA-ACE 7900
HANDLEBAR	CANNONDALE C2 COMPACT, 2014 DOUBLE BUTTED ALLOY
GRIPS	CANNONDALE 2.5MM SUEDE W/GEL BACKING BAR TAPE
STEM	CANNONDALE C2, 2014 3D FORGED ALLOY, 31.8MM, 6 DEG.
HEADSET	CAAD10, 1-1/4" LOWER BEARING, 25MM CARBON TOP CAP
BRAKES	SHIMANO ULTEGRA 6700
BRAKE LEVERS	SHIMANO DURA-ACE 7900
SADDLE	PROLOGO SCRATCH
SEATPOST	CANNONDALE C2, UD CARBON, 27.2X300MM
SIZES	48, 50, 52, 54, 56, 58, 60, 63CM
COLOR 1 (CODE)	BLACK ANODIZED (MATTE) (BLA)
COLOR 2 (CODE)	

	CAAD10 3 ULTEGRA
CODE	2RAX3D, 2RAX3C
FRAME	CAAD10, SMARTFORMED 6069 ALLOY, SPEED SAVE, BB30
FORK	CAAD10, SPEED SAVE FULL CARBON, 1-1/8" TO 1-1/4" TAPERED STEERER
RIMS	MAVIC AKSIUM WTS
HUBS	MAVIC AKSIUM WTS
SPOKES	MAVIC AKSIUM WTS
TIRES	SCHWALBE DURANO S, 700X23C, FOLDING
PEDALS	N/A
CRANK	FSA SL-K LIGHT CARBON, BB30, 53/39 (OPTION: COMPACT 50/34)
BOTTOM BRACKET	FSA BB30
CHAIN	SHIMANO ULTEGRA 6700
REAR COGS	SHIMANO ULTEGRA 6700, 12-25, 10-SPEED
FR. DERAILLEUR	SHIMANO ULTEGRA 6700, BRAZE-ON
REAR DERAILLEUR	SHIMANO ULTEGRA 6700
SHIFTERS	SHIMANO ULTEGRA 6700
HANDLEBAR	CANNONDALE C3 COMPACT, 6061 DOUBLE BUTTED ALLOY
GRIPS	CANNONDALE 2.5MM SUEDE W/GEL BACKING BAR TAPE
STEM	CANNONDALE C3, 6061 3D FORGED ALLOY, 31.8MM, 6 DEG.
HEADSET	CAAD10, 1-1/4" LOWER BEARING, 25MM TOP CAP
BRAKES	SHIMANO ULTEGRA 6700
BRAKE LEVERS	SHIMANO ULTEGRA 6700
SADDLE	PROLOGO SCRATCH
SEATPOST	CANNONDALE C2, UD CARBON, 27.2X300MM
SIZES	48, 50, 52, 54, 56, 58, 60, 63CM
COLOR 1 (CODE)	JET BLACK W/CHARCOAL GREY (MATTE) (BBQ)
COLOR 2 (CODE)	MAGNESIUM WHITE W/RACE RED (GLOSS) (WHT)

	CAAD10 4 RIVAL
CODE	2RAX4D, 2RAX4C
FRAME	CAAD10, SMARTFORMED 6069 ALLOY, SPEED SAVE, BB30
FORK	CAAD10, SPEED SAVE FULL CARBON, 1-1/8" TO 1-1/4" TAPERED STEERER
RIMS	FULCRUM RACING 7
HUBS	FULCRUM RACING 7
SPOKES	FULCRUM RACING 7
TIRES	SCHWALBE LUGANO, 700X23C, FOLDING
PEDALS	N/A
CRANK	SRAM S500 BB30, 53/39 (OPTION: COMPACT 50/34)
BOTTOM BRACKET	SRAM BB30
CHAIN	KMC DX 10SC
REAR COGS	SRAM PG-1070, 11-26, 10-SPEED
FR. DERAILLEUR	SRAM RIVAL, BRAZE-ON
REAR DERAILLEUR	SRAM RIVAL
SHIFTERS	SRAM RIVAL
HANDLEBAR	CANNONDALE C3 COMPACT, 6061 DOUBLE BUTTED ALLOY
GRIPS	CANNONDALE 2.5MM SUEDE W/GEL BACKING BAR TAPE
STEM	CANNONDALE C3, 6061 3D FORGED ALLOY, 31.8MM, 6 DEG.
HEADSET	CAAD10, 1-1/4" LOWER BEARING, 25MM TOP CAP
BRAKES	SRAM RIVAL
BRAKE LEVERS	SRAM RIVAL
SADDLE	PROLOGO KAPPA
SEATPOST	CANNONDALE C3 CARBON WRAP, 27.2X300MM
SIZES	48, 50, 52, 54, 56, 58, 60, 63CM
COLOR 1 (CODE)	40 BLUE W/40 ORANGE (GLOSS) (BLU)
COLOR 2 (CODE)	BRUSHED ALUMINUM W/CHARCOAL GRAY (GLOSS) (RAW)

	CAAD10 5 105
CODE	2RAX5D, 2RAX5C
FRAME	CAAD10, SMARTFORMED 6069 ALLOY, SPEED SAVE, BB30
FORK	CAAD10, SPEED SAVE FULL CARBON, 1-1/8" TO 1-1/4" TAPERED STEERER
RIMS	SHIMANO RS10
HUBS	SHIMANO RS10
SPOKES	SHIMANO RS10
TIRES	SCHWALBE LUGANO, 700X23C, FOLDING
PEDALS	N/A
CRANK	FSA GOSSAMER PRO, BB30, 53/39 (OPTION: COMPACT 50/34)
BOTTOM BRACKET	FSA BB30
CHAIN	SHIMANO 105 5700
REAR COGS	SHIMANO 105 5700, 12-27, 10-SPEED
FR. DERAILLEUR	SHIMANO 105 5700, BRAZE-ON
REAR DERAILLEUR	SHIMANO 105 5700
SHIFTERS	SHIMANO 105 5700
HANDLEBAR	CANNONDALE C3 COMPACT, 6061 DOUBLE BUTTED ALLOY
GRIPS	CANNONDALE 2.5MM SUEDE W/GEL BACKING BAR TAPE
STEM	CANNONDALE C3, 6061 3D FORGED ALLOY, 31.8MM, 6 DEG.
HEADSET	CAAD10, 1-1/4" LOWER BEARING, 25MM TOP CAP
BRAKES	TEKTRO R580
BRAKE LEVERS	SHIMANO 105 5700
SADDLE	PROLOGO KAPPA
SEATPOST	CANNONDALE C3 CARBON WRAP, 27.2X300MM
SIZES	48, 50, 52, 54, 56, 58, 60, 63CM
COLOR 1 (CODE)	JET BLACK W/CHARCOAL GRAY (MATTE) (BBQ)
COLOR 2 (CODE)	LIQUIGAS TEAM REPLICA (GLOSS) (REP)

	CAAD8 5 105
CODE	2RAB5C
FRAME	NEW CAAD8, OPTIMIZED 6061 ALLOY, SAVE, BB30
FORK	CANNONDALE ULTRA, CARBON BLADES, 1-1/8" TO 1-1/4" TAPERED STEERER
RIMS	MADDUX RS 3.0 SPEED, 32 HOLE
HUBS	FORMULA, RB-51 FRONT, RB-52 REAR
SPOKES	STAINLESS STEEL, 15G
TIRES	SCHWALBE LUGANO, 700X23C
PEDALS	N/A
CRANK	FSA GOSSAMER, BB30, 50/34
BOTTOM BRACKET	FSA BB30
CHAIN	KMC X10
REAR COGS	SHIMANO TIAGRA 4600, 12-28, 10-SPEED
FR. DERAILLEUR	SHIMANO 105 5700, 31.8MM CLAMP
REAR DERAILLEUR	SHIMANO 105 5700
SHIFTERS	SHIMANO 105 5700
HANDLEBAR	CANNONDALE C3 COMPACT, 6061 DOUBLE BUTTED ALLOY
GRIPS	CANNONDALE 2.5MM SUEDE W/GEL BACKING BAR TAPE
STEM	CANNONDALE C3, 6061 3D FORGED ALLOY, 31.8MM, 6 DEG.
HEADSET	TANGE SEIKI INTEGRATED, 25MM TOP CAP
BRAKES	TEKTRO R540, DUAL PIVOT, CARTRIDGE PAD
BRAKE LEVERS	SHIMANO 105 5700
SADDLE	CANNONDALE STAGE ERGO W/CRMO RAILS
SEATPOST	CANNONDALE C3, CARBON WRAP, 27.2X300MM
SIZES	48, 51, 54, 56, 58, 61CM
COLOR 1 (CODE)	JET BLACK (GLOSS) (BLK)
COLOR 2 (CODE)	NIAGRA BLUE (GLOSS) (BLU)

	SUPERSIX ULTEGRA D12
CODE	2RSSIC
FRAME	SUPERSIX, FULL CARBON, BB30
FORK	SUPERSIX, FULL CARBON, 1-1/8" TO 1.5" TAPERED STEERER, ALLOY DROPOUTS
RIMS	MAVIC KSYRIUM ELITE
HUBS	MAVIC KSYRIUM ELITE
SPOKES	MAVIC KSYRIUM ELITE
TIRES	SCHWALBE DURANO S, 700X23C, FOLDING
PEDALS	N/A
CRANK	FSA SL-K LIGHT CARBON BB30, 50/34
BOTTOM BRACKET	FSA BB30
CHAIN	SHIMANO ULTEGRA 6700
REAR COGS	SHIMANO ULTEGRA 6700 12-25, 10-SPEED
FR. DERAILLEUR	SHIMANO ULTEGRA D12, BRAZE-ON W/34.9MM CLAMP
REAR DERAILLEUR	SHIMANO ULTEGRA D12
SHIFTERS	SHIMANO ULTEGRA D12

ROAD SPECIFICATIONS

CODE	SYNAPSE CARBON 4 RIVAL	SYNAPSE CARBON 5 105	SYNAPSE CARBON 6 APEX	SYNAPSE ALLOY 5 105	SYNAPSE ALLOY 6 TIAGRA
FRAME	(2RCS4C)	2RCS5C	2RCS6C	2RAS5C, 2RAS7	2RAS6C, 2RAS8T
FORK	SYNAPSE, FULL CARBON, SAVE PLUS, BB30	SYNAPSE, FULL CARBON, SAVE PLUS, BB30	SYNAPSE, FULL CARBON, SAVE PLUS, BB30	SYNAPSE ALLOY, OPTIMIZED 6061 ALLOY, SAVE PLUS, BB30	SYNAPSE ALLOY, OPTIMIZED 6061 ALLOY, SAVE PLUS, BB30
RIMS	SYNAPSE, FULL CARBON, SAVE PLUS, 1-1/8"	SYNAPSE, FULL CARBON, SAVE PLUS, 1-1/8"	SYNAPSE, CARBON BLADES, SAVE, 1-1/8"	SYNAPSE SAVE, CARBON BLADES, 1-1/8"	SYNAPSE SAVE, CARBON BLADES, 1-1/8"
HUBS	MAVIC AKSIUM WTS	SHIMANO RS10	SHIMANO R501A	SHIMANO RS10	MADDOUX RS 3.0, 32 HOLE
SPOKES	MAVIC AKSIUM WTS	SHIMANO RS10	SHIMANO R501A	SHIMANO RS10	FORMULA RB-51, RB-52
TIRES	MAVIC AKSION WTS, 700X25C	SCHWALBE LUGANO, 700X25C	SCHWALBE LUGANO WIRE, 700X25C, BLACK	SCHWALBE LUGANO, 700X25C	STAINLESS STEEL, 15G
PEDALS	N/A	N/A	N/A	N/A	SCHWALBE LUGANO, 700X25C
CRANK	SRAM S550, BB30, 50/34	FSA GOSSAMER PRO, BB30, 50/34	FSA OMEGA BB30, 50/34	FSA GOSSAMER, BB30, 50/34 (OPTION: TRIPLE 50/39/30)	FSA OMEGA, BB30, 50/34 (OPTION: TRIPLE 50/39/30)
BOTTOM BRACKET	SRAM BB30	FSA BB30	FSA BB30	FSA BB30	FSA BB30
CHAIN	KMC, DX10SC	SHIMANO 105 5700	KMC DX10SC	KMC X10	KMC X10
REAR COGS	SRAM APEX, 11-32, 10-SPEED	SHIMANO 105 5700, 11-28, 10-SPEED	SRAM APEX, 11-32, 10-SPEED	SHIMANO TIAGRA 4600, 12-28, 10-SPEED	SHIMANO TIAGRA 4600, 12-28, 10-SPEED
FR. DERAILLEUR	SRAM RIVAL, BRAZE-ON	SHIMANO 105 5700, BRAZE-ON	SRAM APEX, BRAZE-ON	SHIMANO 105 5700, 34.9MM CLAMP	SHIMANO TIAGRA 4600, 34.9MM CLAMP
REAR DERAILLEUR	SRAM RIVAL WIFLI	SHIMANO 105 5700	SRAM APEX WIFLI	SHIMANO 105 5700	SHIMANO TIAGRA 4600
SHIFTERS	SRAM RIVAL	SHIMANO 105 5700	SRAM APEX	SHIMANO 105 5700	SHIMANO TIAGRA 4600
HANDLEBAR	CANNONDALE C2 COMPACT, 2014 DOUBLE BUTTED ALLOY, 2014 DOUBLE BUTTED ALLOY	CANNONDALE C3 COMPACT, 6061 DOUBLE BUTTED ALLOY	CANNONDALE C3 COMPACT, 6061 DOUBLE BUTTED ALLOY	CANNONDALE C3 COMPACT, 6061 DOUBLE BUTTED ALLOY	CANNONDALE C4 COMPACT
GRIPS	CANNONDALE 3MM SUEDE W/GEL BACKING BAR TAPE	CANNONDALE 3MM SUEDE W/GEL BACKING BAR TAPE	CANNONDALE 3MM SUEDE W/GEL BACKING BAR TAPE	CANNONDALE 3MM SUEDE W/GEL BACKING BAR TAPE	CANNONDALE 3MM SUEDE W/GEL BACKING BAR TAPE
STEM	CANNONDALE C2, 2014 3D FORGED ALLOY, 31.8MM, 6 DEG.	CANNONDALE C2, 2014 3D FORGED ALLOY, 31.8MM, 6 DEG.	CANNONDALE C3, 6061 3D FORGED ALLOY, 31.8MM, 6 DEG.	CANNONDALE C3, 6061 3D FORGED ALLOY, 31.8MM, 6 DEG.	CANNONDALE C4, 31.8, 6 DEG.
HEADSET	SYNAPSE SI, 25MM TOP CAP	SYNAPSE SI, 25MM TOP CAP	SYNAPSE SI, 25MM TOP CAP	SYNAPSE SI, 25MM TOP CAP	SYNAPSE SI, 25MM TOP CAP
BRAKES	SRAM DUAL PIVOT	TEKTRO R580	SRAM APEX	TEKTRO R539, DUAL PIVOT, CARTRIDGE PAD, LONG REACH	CANNONDALE C4, DUAL PIVOT, CARTRIDGE PAD, LONG REACH
BRAKE LEVERS	SRAM RIVAL	SHIMANO 105 5700	SRAM APEX	SHIMANO 105 5700	SHIMANO TIAGRA 4600
SADDLE	PROLOGO SCRATCH PRO T2.0	PROLOGO KAPPA	CANNONDALE STAGE ERGO W/CRMO RAILS	CANNONDALE STAGE ERGO W/CRMO RAILS	CANNONDALE STAGE ERGO W/STEEL RAILS
SEATPOST	SYNAPSE SAVE PLUS MULTIFLEX, (SOFT 48-54, FIRM 56-61)	SYNAPSE SAVE PLUS MULTIFLEX, (SOFT 48-54, FIRM 56-61)	SYNAPSE SAVE PLUS MULTIFLEX, (SOFT 48-54, FIRM 56-61)	CANNONDALE C3, CARBON WRAPPED, 27.2X300MM	CANNONDALE C4, ALLOY, 27.2X300MM
SIZES	48, 51, 54, 56, 58, 61CM	48, 51, 54, 56, 58, 61CM	48, 51, 54, 56, 58, 61CM	48, 51, 54, 56, 58, 61CM	48, 51, 54, 56, 58, 61CM
COLOR 1 (CODE)	EXPOSED CARBON W/CHARCOAL GREY AND ULTRA BLUE (GLOSS) (BLU)	EXPOSED CARBON W/MAGNESIUM WHITE (GLOSS) (BLK)	EXPOSED CARBON W/CHARCOAL GREY AND ULTRA BLUE (GLOSS) (BLU)	BRUSHED ALUMINUM (GLOSS) (RAW)	JET BLACK (MATTE) (BBQ)
COLOR 2 (CODE)	MAGNESIUM WHITE W/JET BLACK AND CHARCOAL GREY (GLOSS) (WHT)	MAGNESIUM WHITE W/RACE RED AND JET BLACK (GLOSS) (RED)	MAGNESIUM WHITE W/JET BLACK AND CHARCOAL GREY (GLOSS) (WHT)	MAGNESIUM WHITE (GLOSS) (WHT)	INDIGO BLUE (GLOSS) (BLU)

CODE	SYNAPSE ALLOY 7 SORA	SLICE 4 FORCE	SLICE 5 105	SUPERX 2 SRAM RED	SUPERX 3 ULTEGRA
FRAME	2RAS7T	2RM4D	2RM5D	2XC2C	2XC3C
FORK	SYNAPSE ALLOY, OPTIMIZED 6061 ALLOY, SAVE PLUS	SLICE, FULL CARBON, AERO SAVE, BB30	SLICE, FULL CARBON, AERO SAVE, BB30	SUPERX, BALLISTEC HI-MOD CARBON, SPEED SAVE, BB30	SUPERX, BALLISTEC CARBON, SPEED SAVE, BB30
RIMS	SYNAPSE SAVE, CARBON BLADES, 1-1/8"	SLICE AERO, FULL CARBON, 1-1/8"	SLICE AERO, FULL CARBON, 1-1/8"	SUPERX, BALLISTEC HI-MOD FULL CARBON, 1-1/8" TO 1-1/4" STEERER	SUPERX, BALLISTEC CARBON, 1-1/8" TO 1-1/4" STEERER
HUBS	MADDOUX RS 3.0, 32 HOLE	FULCRUM RACING 7	SHIMANO R501A	MAVIC KSYRIUM ELITE	MAVIC KSYRIUM EQUIPE
SPOKES	FORMULA RB-51, RB-52	FULCRUM RACING 7	SHIMANO R501A	MAVIC KSYRIUM ELITE	MAVIC KSYRIUM EQUIPE
TIRES	STAINLESS STEEL, 15G	FULCRUM RACING 7	SHIMANO R501A	MAVIC KSYRIUM ELITE	MAVIC KSYRIUM EQUIPE
PEDALS	SCHWALBE LUGANO, 700X25C	SCHWALBE LUGANO, 700X23C, FOLDING	SCHWALBE LUGANO, 700X23C, FOLDING	SCHWALBE RACING RALPH, 700X33C	SCHWALBE SAMMY SLICK, 700X35C
CRANK	N/A	N/A	N/A	N/A	N/A
BOTTOM BRACKET	FSA VERO, 50/39/30	SRAM S500 BB30, 53/39	FSA GOSSAMER PRO BB30, 52/38	FSA SLK LIGHT CARBON, BB30, 46/36	FSA GOSSAMER PRO, BB30, 46/36
CHAIN	FSA	SRAM BB30	FSA BB30	FSA BB30	FSA BB30
REAR COGS	KMC X9	KMC DX10SC	SHIMANO 105 5700	KMC X10SL	SHIMANO ULTEGRA 6700
FR. DERAILLEUR	SRAM PG-950, 12-26, 9-SPEED	SRAM PG-1050, 11-26, 10-SPEED	SHIMANO 105 5700, 12-25, 10-SPEED	SRAM PG-1070, 11-26, 10-SPEED	SHIMANO ULTEGRA 6700, 12-25, 10-SPEED
REAR DERAILLEUR	SHIMANO SORA	SRAM FORCE, BRAZE-ON	SHIMANO 105 5700, BRAZE-ON	SRAM RED, BRAZE-ON	SHIMANO ULTEGRA 6700, BRAZE-ON
SHIFTERS	SHIMANO SORA	SRAM FORCE	SHIMANO 105 5700	SRAM RED	SHIMANO ULTEGRA 6700
HANDLEBAR	CANNONDALE C4 COMPACT	SRAM TT500	MICROSHIFT BAR-END	SRAM RED	SHIMANO ULTEGRA
GRIPS	CANNONDALE C3 COMPACT, 2014 DOUBLE BUTTED ALLOY, 2014 DOUBLE BUTTED ALLOY	CANNONDALE C3 AERO BAR, 31.8 W/FSA VECTOR CARBON CLIP-ONS	CANNONDALE C3 BASE BAR, 31.8 W/FSA TRI MAX TEAM CLIP-ONS	FSA ENERGY COMPACT	CANNONDALE C2 COMPACT, 2014 DOUBLE BUTTED ALLOY, 2014 DOUBLE BUTTED ALLOY
STEM	CANNONDALE C4, 31.8, 6 DEG.	CANNONDALE 2.5MM SUEDE W/GEL BACKING BAR TAPE	CANNONDALE 2.5MM SUEDE W/GEL BACKING BAR TAPE	CANNONDALE 3MM SUEDE W/GEL BACKING BAR TAPE	CANNONDALE 3MM SUEDE W/GEL BACKING BAR TAPE
HEADSET	SYNAPSE SI, 25MM TOP CAP	CANNONDALE C3, 6061 3D FORGED ALLOY, 31.8MM, 6 DEG.	CANNONDALE C3, 6061 3D FORGED ALLOY, 31.8MM, 6 DEG.	FSA SL-K, 31.8	CANNONDALE C2, 2014 3D FORGED ALLOY, 31.8MM, 6 DEG.
BRAKES	SRAM DUAL PIVOT	SLICE, SI, 15MM TOP CAP	SLICE, SI, 15MM TOP CAP	CANNONDALE SUPERX, 1-1/8" TO 1-1/4", 15MM TOP CAP	CANNONDALE SUPERX, 1-1/8" TO 1-1/4", 15MM TOP CAP
BRAKE LEVERS	SRAM RIVAL	SRAM RIVAL	TEKTRO R580	FSA SL-K	TRP EURO X
SADDLE	SHIMANO SORA	ALLOY AERO LEVERS	ALLOY AERO LEVERS	SRAM RED	SHIMANO ULTEGRA
SEATPOST	CANNONDALE STAGE ERGO W/STEEL RAILS	FI'ZIK ARIONE TRIZ, W/MG RAILS	CANNONDALE ERGO TRI	FI'ZIK TUNDRA 2	FI'ZIK TUNDRA 2
SIZES	CANNONDALE C4, ALLOY, 27.2X300MM	CANNONDALE SLICE CARBON AERO, 2 POSITION	CANNONDALE SLICE CARBON AERO, 2 POSITION	FSA SLK, 27.2MMX250MM	CANNONDALE C2, UD CARBON, 27.2X300MM
COLOR 1 (CODE)	48, 51, 54, 56, 58, 61CM	44, 48, 52, 54, 56, 58, 60CM	51, 54, 56, 58, 60CM	44, 48, 52, 54, 56, 58CM	44, 48, 52, 54, 56, 58CM
COLOR 2 (CODE)	RACE RED (GLOSS) (RED)	MAGNESIUM WHITE W/JET BLACK AND RACE RED (GLOSS) (WHT)	MAGNESIUM WHITE W/JET BLACK AND RACE RED (GLOSS) (WHT)	JET BLACK W/BERSERKER GREEN (GLOSS) (GRN)	MAGNESIUM WHITE W/JET BLACK (GLOSS) (WHT)

ROAD SPECIFICATIONS

CODE	SUPERX 4 RIVAL	CAADX 5 105	CAADX 6 TIAGRA
FRAME	2XC4C	2XR5C	2XR6C
FORK	SUPERX, BALLISTEC CARBON, SPEED SAVE, BB30	CAADX CYCLOCROSS, OPTIMIZED 6061 ALLOY, BB30	CAADX CYCLOCROSS, OPTIMIZED 6061 ALLOY, BB30
REAR SHOCK	N/A	N/A	N/A
RIMS	SUPERX, BALLISTEC CARBON, 1-1/8" TO 1-1/4" STEERER	CANNONDALE ULTRA X, CARBON BLADES, 1-1/8"	CANNONDALE ULTRA X, CARBON BLADES, 1-1/8"
HUBS	N/A	MADDOUX DRX 6000, 32 HOLE	MADDOUX DRX 6000, 32 HOLE
SPOKES	FULCRUM RACING 7 CX	FORMULA, RB-51 FRONT, RB-52 REAR	FORMULA, RB-51 FRONT, RB-52 REAR
TIRES	FULCRUM RACING 7 CX	STAINLESS STEEL, 15G	STAINLESS STEEL, 15G
PEDALS	SCHWALBE RAPID ROB, 700X35C	SCHWALBE SAMMY SLICK, 700X35C	SCHWALBE SAMMY SLICK, 700X35C
CRANK	N/A	N/A	N/A
BOTTOM BRACKET	FSA GOSSAMER PRO, BB30, 46/36	FSA GOSSAMER, BB30, 46/36	FSA OMEGA BB30, 46/36
CHAIN	FSA BB30	FSA BB30	FSA BB30
REAR COGS	KMC X10SL	KMC X10	KMC X10
FR. DERAILLEUR	SRAM PG-1050, 11-26, 10-SPEED	SHIMANO TIAGRA 4600, 12-28, 10-SPEED	SHIMANO TIAGRA 4600, 12-28, 10-SPEED
REAR DERAILLEUR	SRAM RIVAL, BRAZE-ON	SHIMANO 105 5700, 34.9MM CLAMP	SHIMANO TIAGRA 4600, 34.9MM CLAMP
SHIFTERS	SRAM RIVAL	SHIMANO 105 5700	SHIMANO TIAGRA 4600
HANDLEBAR	SRAM RIVAL	SHIMANO 105 5700	SHIMANO TIAGRA 4600
GRIPS	CANNONDALE C2 COMPACT, 2014 DOUBLE BUTTED ALLOY, 2014 DOUBLE BUTTED ALLOY	CANNONDALE C3 COMPACT, 6061 DOUBLE BUTTED ALLOY	CANNONDALE C4 COMPACT
STEM	CANNONDALE 3MM SUEDE W/GEL BACKING BAR TAPE	CANNONDALE 3MM SUEDE W/GEL BACKING BAR TAPE	CANNONDALE 3MM SUEDE W/GEL BACKING BAR TAPE
HEADSET	CANNONDALE C2, 2014 3D FORGED ALLOY, 31.8MM, 6 DEG.	CANNONDALE C3, 6061 3D FORGED ALLOY, 31.8MM, 6 DEG.	CANNONDALE C4, 31.8, 6 DEG.
BRAKES	CANNONDALE C2, 2014 3D FORGED ALLOY, 31.8MM, 6 DEG.	CANNONDALE C3, 6061 3D FORGED ALLOY, 31.8MM, 6 DEG.	CANNONDALE C4, 31.8, 6 DEG.
BRAKE LEVERS	CANNONDALE C4, DUAL PIVOT, CARTRIDGE PAD, LONG REACH	CAADX SI, 25MM TOP CAP	CAADX SI, 25MM TOP CAP
SADDLE	TRP EURO X	TEKTRO CR710	TEKTRO CR520
SEATPOST	SRAM RIVAL	SHIMANO 105 5700	SHIMANO TIAGRA 4600
SIZES	FI'ZIK TUNDRA 2	CANNONDALE STAGE W/CRMO RAILS	CANNONDALE STAGE W/STEEL RAILS
COLOR 1 (CODE)	CANNONDALE C3 CARBON WRAP, 27.2X300MM	CANNONDALE C3 ALLOY, 31.6MMX300MM	CANNONDALE C4 ALLOY, 31.6MMX300MM
EXTRAS	44, 48, 52, 54, 56, 58CM	44, 48, 51, 54, 56, 58, 61CM	44, 48, 51, 54, 56, 58, 61CM
EXTRAS	MAGNESIUM WHITE W/JET BLACK (GLOSS) (WHT)	BRUSHED ALUMINUM (GLOSS) (RAW)	JET BLACK (MATTE) (BBQ)

MOUNTAIN SPECIFICATIONS

CODE	CLAYMORE 1	CLAYMORE 2	JEKYLL CARBON 1	JEKYLL CARBON 2	JEKYLL ALLOY 3
FRAME	2VA1	2VA2	2VN1	2VN2	2VN3
FORK	CLAYMORE, 180/110MM, SMARTFORMED ALLOY, BB30, ISCG03, DIABLO 1.5 SI HEAD TUBE	CLAYMORE, 180/110MM, SMARTFORMED ALLOY, BB30, ISCG03, DIABLO 1.5 SI HEAD TUBE	JEKYLL, 150/90MM, BALLISTEC HI-MOD CARBON, BB30, ISCG03, 1.5 SI HEAD TUBE	JEKYLL, 150/90MM, BALLISTEC HI-MOD CARBON, BB30, ISCG03, 1.5 SI HEAD TUBE	JEKYLL, 150/90MM, BALLISTEC HI-MOD CARBON, BB30, ISCG03, 1.5 SI HEAD TUBE
REAR SHOCK	FOX TALAS R, 180MM, 200R THRU AXLE, 1.5"	FOX VAN R O/B, 180MM, 200R THRU AXLE, 1.5"	FOX 32 TALAS RLC FIT, 150MM, 15QR THRU AXLE, 1.5"	FOX 32 TALAS RL W/CUSTOM LOCKOUT THRESHOLD, 150MM, 15QR THRU AXLE, 1.5"	FOX 32 TALAS RL W/CUSTOM LOCKOUT THRESHOLD, 150MM, 15QR THRU AXLE, 1.5"
RIMS	FOX DYAD RT2 DUAL SHOCK 180/110MM	FOX DYAD RT2 DUAL SHOCK 180/110MM	FOX DYAD RT2 DUAL SHOCK 150/90MM	FOX DYAD RT2 DUAL SHOCK 150/90MM	FOX DYAD RT2 DUAL SHOCK 150/90MM
HUBS	SUNRINGLE CHARGER PRO, TUBELESS READY	SUNRINGLE INFERNO 27, 32 HOLE	MAVIC CROSSMAX ST, TUBELESS	SUNRINGLE BLACKFLAG EXPERT +, TUBELESS READY	SUNRINGLE INFERNO25, 32 HOLE
SPOKES	SUNRINGLE CHARGER PRO, 20MM FRONT, 142X12MM REAR	FORMULA, 32 HOLE, THRU20 FRONT, 142X12MM REAR	MAVIC CROSSMAX ST, 15MM FRONT, 142X12MM REAR	SUNRINGLE BLACKFLAG EXPERT +, 24 HOLE, 15MM FRONT, 142X12MM REAR	FORMULA, 15MM FRONT, SUN RINGLE DIRTY FLEA 142X12MM REAR
TIRES	SUNRINGLE CHARGER PRO	DT SWISS CHAMPION BLK 1.8MM	MAVIC CROSSMAX ST	SUNRINGLE BLACKFLAG EXPERT +	DT SWISS CHAMPION
PEDALS	SCHWALBE HANS DAMPF SNAKESKIN TRAILSTAR, 2.35" TUBELESS READY	SCHWALBE HANS DAMPF PERFORMANCE, 2.35", FOLDING	SCHWALBE HANS DAMPF SNAKESKIN TRAILSTAR, 2.35" TUBELESS READY	SCHWALBE HANS DAMPF SNAKESKIN TRAILSTAR, 2.35" TUBELESS READY	SCHWALBE HANS DAMPF SNAKESKIN TRAILSTAR, 2.35" TUBELESS READY
CRANK	N/A	N/A	N/A	N/A	N/A
BOTTOM BRACKET	SRAM S1400, BB30, 36/22	SRAM S1400, BB30, 36/22	SRAM S2210, BB30, 38/24	SRAM S2210, BB30, 38/24	SRAM S1400, BB30, 44/33/22
CHAIN	SRAM BB30	SRAM BB30	SRAM BB30	SRAM BB30	SRAM BB30
REAR COGS	KMC X10SL, 10-SPEED	KMC X10, 10-SPEED	KMC X10SL, 10-SPEED	KMC X10SL, 10-SPEED	KMC X10, 10-SPEED
FR. DERAILLEUR	SRAM PG-1070, 11-36, 10-SPEED	SRAM PG-1030, 11-36, 10-SPEED	SRAM PG-1070, 11-36, 10-SPEED	SRAM PG-1070, 11-36, 10-SPEED	SHIMANO HG-62, 11-36, 10-SPEED
REAR DERAILLEUR	SRAM X9, DIRECT MOUNT	SRAM X7, DIRECT MOUNT	SRAM X9, DIRECT MOUNT	SRAM X7, DIRECT MOUNT	SRAM X7, DIRECT MOUNT
SHIFTERS	SHIMANO XT	SRAM X9	SHIMANO XTR	SRAM X9	SHIMANO XT
HANDLEBAR	SHIMANO XT	SRAM X7	SHIMANO XT	SRAM X9	SHIMANO SLX
GRIPS	FSA GRAVITY LITE, 710X25MM RISE	CANNONDALE C3 RISER, 740X18MM, 2014 ALLOY	TRUVATIV NOIR, 700X25MM RISE	CANNONDALE C2 RISER, 680X20MM, 2014 ALLOY	CANNONDALE C2 RISER, 680X20MM, 2014 ALLOY
STEM	CANNONDALE ALLOY LOCKING GRIPS W/ CLOSED END	CANNONDALE ALLOY LOCKING GRIPS W/ CLOSED END	CANNONDALE ALLOY LOCKING GRIPS W/ CLOSED END	CANNONDALE ALLOY LOCKING GRIPS W/ CLOSED END	CANNONDALE ALLOY LOCKING GRIPS W/ CLOSED END
HEADSET	FSA GRAVITY LITE, 1.5", 31.8	CANNONDALE C3, 1.5", 31.8	CANNONDALE C1, 1.5", 31.8	CANNONDALE C1, 1.5", 31.8	CANNONDALE C1, 1.5", 31.8
BRAKES	TANGE SEIKI 1.5", SI ANGULAR CONTACT	TANGE SEIKI 1.5", SI ANGULAR CONTACT	TANGE SEIKI 1.5", INTEGRATED	TANGE SEIKI 1.5", INTEGRATED	TANGE SEIKI 1.5", INTEGRATED
BRAKE LEVERS	AVID ELIXIR 9, 200/180MM	AVID ELIXIR 7, 200/180MM	AVID ELIXIR 9 CARBON, 180/180MM	AVID ELIXIR 7 CARBON, 180/180MM	AVID ELIXIR 7, 180/180MM
SADDLE	AVID ELIXIR 9	AVID ELIXIR 7	AVID ELIXIR 9 CARBON	AVID ELIXIR 7 CARBON	AVID ELIXIR 7
SEATPOST	PROLOGO SCRATCH X18	CANNONDALE STAGE CRMO	CANNONDALE STAGE CRMO	CANNONDALE STAGE CRMO	CANNONDALE STAGE CRMO
SIZES	X FUSION HILO, 31.6X385MM HEIGHT ADJUSTABLE W/REMOTE	CANNONDALE C2, 31.6X350MM	ROCKSHOX REVERB, 31.6X385MM HEIGHT ADJUSTABLE	CANNONDALE C2, 31.6X350MM	CANNONDALE C2, 31.6X350MM
COLOR 1 (CODE)	S, M, L	S, M, L	S, M, L, X	S, M, L, X	S, M, L, X
COLOR 2 (CODE)	JET BLACK (MATTE) (BBQ)	JET BLACK (MATTE) (BBQ)	EXPOSED CARBON W/MAGNESIUM WHITE (MATTE) (BBQ)	CHARCOAL GRAY W/JET BLACK (MATTE) (GRY)	JET BLACK (GLOSS) (BLK)
EXTRAS	HIGH PRESSURE SHOCK PUMP, DYAD REMOTE LEVER, SYNTACE X-12 142 MM REAR AXLE	HIGH PRESSURE SHOCK PUMP, DYAD REMOTE LEVER, SYNTACE X-12 142 MM REAR AXLE	HIGH PRESSURE SHOCK PUMP, DYAD REMOTE LEVER, SYNTACE X-12 142 MM REAR AXLE	HIGH PRESSURE SHOCK PUMP, DYAD REMOTE LEVER, SYNTACE X-12 142 MM REAR AXLE	HIGH PRESSURE SHOCK PUMP, DYAD REMOTE LEVER, SYNTACE X-12 142 MM REAR AXLE

MOUNTAIN SPECIFICATIONS

	JEKYLL ALLOY 4	RZ ONE TWENTY 2	RZ ONE TWENTY 3	SCALPEL TEAM	SCALPEL 2
CODE	ZVN4	ZVL2	ZVL3	ZVP0	ZVP2
FRAME	JEKYLL, 150/90MM, SMARTFORMED ALLOY, BB30, 1.5 SI HEAD TUBE	RZ ONE TWENTY, 120MM, SMARTFORMED ALLOY, BB30, 1.5 SI HEAD TUBE	RZ ONE TWENTY, 120MM, SMARTFORMED ALLOY, BB30, 1.5 SI HEAD TUBE	SCALPEL, 80MM, BALLISTEC HI-MOD FULL CARBON, ZERO PIVOT, BB30, 1.5 SI HEAD TUBE	SCALPEL, 80MM, BALLISTEC HI-MOD FULL CARBON, ZERO PIVOT, BB30, 1.5 SI HEAD TUBE
FORK	ROCKSHOX SEKTOR TK, DUAL POSITION, LOCKOUT, REBOUND, 15QR THRU AXLE, 1.5"	ROCKSHOX RECON GOLD TK, 120MM, SOLO AIR, LOCKOUT, REBOUND, 1.5"	ROCKSHOX RECON SILVER TK, 120MM, SOLO AIR, LOCKOUT, REBOUND, 20MM THRU AXLE, 1.5"	LEFTY SPEED CARBON XLR, 100MM, OPI, SOLO AIR	LEFTY SPEED XLR, 100MM, OPI, SOLO AIR
REAR SHOCK	FOX DYAD RT2 DUAL SHOCK 150/90MM	ROCKSHOX MONARCH RT	X FUSION E1RL	ROCKSHOX MONARCH RT3	ROCKSHOX MONARCH RT
RIMS	SUNRINGLE INFERNO25, 32 HOLE	SUNRINGLE SR25, 28 HOLE FRONT, 32 HOLE REAR	MADDEX DC 3.0, DOUBLE WALL, EYELETED, 28 HOLE FRONT, 32 HOLE REAR	MAVIC CROSSMAX SLR, TUBELESS	SUNRINGLE BLACKFLAG PRO, 24 HOLE, TUBELESS READY
HUBS	FORMULA, 15MM FRONT, 142X12MM REAR	FORMULA DC20 FRONT, DC22 REAR	FORMULA DC20 FRONT, DC22 REAR	MAVIC CROSSMAX SLR LEFTY	SUNRINGLE BLACKFLAG PRO LEFTY
SPOKES	DT SWISS CHAMPION	DT SWISS CHAMPION	DT SWISS CHAMPION	MAVIC CROSSMAX SLR	SUNRINGLE BLACKFLAG PRO
TIRES	SCHWALBE HANS DAMPF SNAKESKIN TRAILSTAR, 2.35" TUBELESS READY	SCHWALBE RAPID ROB, 2.25"	SCHWALBE RAPID ROB, 2.25"	SCHWALBE FURIOUS FRED PACESTAR, 26X2.0" TUBELESS READY	SCHWALBE RACING RALPH PACESTAR, 2.1" TUBELESS READY
PEDALS	N/A	FPD ALLOY BODY	FPD ALLOY BODY	N/A	N/A
CRANK	SRAM S1000 3.3, 44/33/22	SHIMANO M552, 42/32/24	SRAM S800 3.2, 44/33/22	CANNONDALE HOLLOWGRAM SL, BB30, 39/26	SRAM S2210, BB30, 39/26
BOTTOM BRACKET	TRUVATIV POWERSPLINE	INCLUDED	TRUVATIV POWERSPLINE	CANNONDALE BB30	SRAM BB30
CHAIN	KMC X10, 10-SPEED	KMC X10, 10-SPEED	KMC X10, 10-SPEED	KMC X10SL, 10-SPEED	KMC X10SL, 10-SPEED
REAR COGS	SRAM PG-1030, 11-36, 10-SPEED	SRAM PG-1030, 11-36, 10-SPEED	SRAM PG-1030, 11-36, 10-SPEED	SRAM XX, 11-36, 10-SPEED	SRAM PG-1070, 11-36, 10-SPEED
FR. DERAILLEUR	SRAM X7, DIRECT MOUNT	SHIMANO SLX, 34.9 HIGH CLAMP	SRAM X5, 34.9 HIGH CLAMP	SRAM XX, DIRECT MOUNT	SRAM X9, DIRECT MOUNT
REAR DERAILLEUR	SRAM X7	SHIMANO XT	SRAM X5	SRAM XX	SRAM X0
SHIFTERS	SRAM X5	SHIMANO SLX	SRAM X5	SRAM XX	SRAM X9
HANDLEBAR	CANNONDALE C3 RISER, 680X20MM, 6061 ALLOY	CANNONDALE C3 RISER, 680X20MM, 6061 ALLOY	CANNONDALE C3 RISER, 680X20MM, 6061 ALLOY	FSA K-FORCE RISER, 660X18MM	CANNONDALE C2 RISER, 680X20MM, 2014 ALLOY
GRIPS	CANNONDALE ALLOY LOCKING GRIPS W/CLOSED END	CANNONDALE ALLOY LOCKING GRIPS W/CLOSED END	CANNONDALE ALLOY LOCKING GRIPS W/CLOSED END	CANNONDALE FOAM LOCKING GRIPS	CANNONDALE FOAM LOCKING GRIPS
STEM	CANNONDALE C4, 1.5", 31.8	CANNONDALE C3, 1.5", 31.8	CANNONDALE C3, 1.5", 31.8	CANNONDALE OPI ADJUSTABLE, -5 DEGREE, 31.8	CANNONDALE OPI ADJUSTABLE, -5 DEGREE, 31.8
HEADSET	TANGE SEIKI 1.5", INTEGRATED	TANGE SEIKI, 1.5", INTEGRATED	TANGE SEIKI, 1.5", INTEGRATED	CANNONDALE HEADSHOK SI	CANNONDALE HEADSHOK SI
BRAKES	AVID ELIXIR 3, 180/180MM	AVID ELIXIR 3, 180/160MM	AVID ELIXIR 1, 180/160MM	AVID XX WORLD CUP, 160/140MM	AVID ELIXIR 9 CARBON 160/140MM
BRAKE LEVERS	AVID ELIXIR 3	AVID ELIXIR 3	AVID ELIXIR 3	AVID XX WORLD CUP	AVID ELIXIR 9 CARBON 160/140MM
SADDLE	CANNONDALE STAGE 2	CANNONDALE STAGE 2	CANNONDALE STAGE 2	FI'ZI-K TUNDRA2 CRB	FI'ZI-K TUNDRA2 MG
SEATPOST	CANNONDALE C2, 31.6X350MM	CANNONDALE C3, 31.6X400MM	CANNONDALE C4, 31.6X400MM	FSA K-FORCE 25MM OFFSET, 31.6X400MM	CANNONDALE C2, 31.6X400MM
SIZES	S, M, L, X	S, M, L, X	S, M, L, X	S, M, L, X	S, M, L, X
COLOR 1 (CODE)	MAGNESIUM WHITE (GLOSS) (WHT)	JET BLACK (MATTE) (BBQ)	JET BLACK (MATTE) (BBQ)	EXPOSED CARBON W/MAGNESIUM WHITE AND BERSERKER GREEN ACCENTS (GLOSS) (REP)	JET BLACK (MATTE) (BLK)
COLOR 2 (CODE)		MAGNESIUM WHITE (GLOSS) (WHT)	FINE SILVER (MATTE) (SLV)		
EXTRAS	HIGH PRESSURE SHOCK PUMP, DYAD REMOTE LEVER, SYNTACE X-12 142 MM REAR AXLE				

	SCALPEL 3	FLASH ALLOY 3	TRAIL SL 2	TRAIL SL 3	TRAIL SL 4
CODE	ZVP3	ZFA3	ZFS2	ZFS3	ZFS4
FRAME	SCALPEL, 80MM, BALLISTEC HI-MOD FULL CARBON, ZERO PIVOT, BB30, 1.5 SI HEAD TUBE	FLASH, SMARTFORMED ALLOY, SPEED SAVE, BB30, 1.5 SI HEAD TUBE	TRAIL SL, OPTIMIZED 6061 ALLOY, SAVE, 1.5" HEAD TUBE	TRAIL SL, OPTIMIZED 6061 ALLOY, SAVE, 1.5" HEAD TUBE	TRAIL SL, OPTIMIZED 6061 ALLOY, SAVE, 1.5" HEAD TUBE
FORK	LEFTY SPEED PBR, 100MM, OPI, SOLO AIR	FATTY DLR80, 80MM, OPI	ROCKSHOX RECON SILVER TK, 100MM, SOLO AIR, LOCKOUT, REBOUND, 1.5"	RST DEUCE COIL, 100MM, COIL/ELASTOMER, LOCKOUT, REBOUND, 1.5"	RST DEUCE TNL, 100MM, COIL/ELASTOMER, LOCKOUT, REBOUND, 1.5"
REAR SHOCK	ROCKSHOX MONARCH RT	N/A	N/A	N/A	N/A
RIMS	DT SWISS XCR 1.7 CUSTOM, 24 HOLE	MADDEX DC3.0, DOUBLE WALL W/EYELET, 28 HOLE FRONT, 32 HOLE REAR	MADDEX DC3.0, DOUBLE WALL W/EYELET, 28 HOLE FRONT, 32 HOLE REAR	MADDEX DC3.0, DOUBLE WALL W/EYELET, 28 HOLE FRONT, 32 HOLE REAR	MADDEX DC3.0, DOUBLE WALL W/EYELET, 28 HOLE FRONT, 32 HOLE REAR
HUBS	LEFTY SL FRONT, DT SWISS 370 REAR	FORMULA DC 20 FRONT, DC 22 REAR	FORMULA, DC20 FRONT, DC22 REAR	CANNONDALE C4 FRONT & REAR	CANNONDALE C4 FRONT & REAR
SPOKES	DT SWISS COMPETITION	DT SWISS CHAMPION	STAINLESS STEEL, 15G, BLACK	STAINLESS STEEL, 15G, BLACK	STAINLESS STEEL, 15G, BLACK
TIRES	SCHWALBE RACING RALPH PACESTAR, 2.1" TUBELESS READY	SCHWALBE RAPID ROB, 2.1"	SCHWALBE RAPID ROB, 2.1"	SCHWALBE RAPID ROB, 2.1"	SCHWALBE RAPID ROB, 2.1"
PEDALS	N/A	FPD ALLOY PLATFORM	FPD ALLOY PLATFORM	FPD PLATFORM, PLASTIC BODY	FPD PLATFORM, PLASTIC BODY
CRANK	SRAM S1400, BB30, 39/26	SHIMANO M552, 42/32/24	SRAM S800 3.1, 44/33/22	SHIMANO FC-M430-8 OCTALINK, 44/32/22	SHIMANO FC-M361, 44/32/22
BOTTOM BRACKET	SRAM BB30	INCLUDED	SRAM POWERSPLINE	SHIMANO BB-ES25, OCTALINK	CANNONDALE BB30
CHAIN	KMC X10SL, 10-SPEED	KMC X10, 10-SPEED	KMC X10, 10-SPEED	SHIMANO HG53, 9-SPEED	SHIMANO HG40, 8-SPEED
REAR COGS	SRAM PG-1030, 11-36, 10-SPEED	SRAM PG-1070, 11-36, 10-SPEED	SHIMANO HG-62, 11-36, 10-SPEED	SUNRACE M96, 11-34, 9-SPEED	SUNRACE M66, 12-32, 8-SPEED
FR. DERAILLEUR	SRAM X7, DIRECT MOUNT	SHIMANO DEORE	SRAM X5, 34.9 CLAMP	SHIMANO ALIVIO, 34.9 CLAMP	SHIMANO ALTUS, 34.9 CLAMP
REAR DERAILLEUR	SHIMANO XT	SHIMANO XT	SRAM X5	SHIMANO DEORE	SHIMANO ALIVIO
SHIFTERS	SHIMANO SLX	SHIMANO SLX	SRAM X5	SHIMANO ALIVIO	SHIMANO ALTUS
HANDLEBAR	CANNONDALE C2 RISER, 680X20MM, 2014 ALLOY	CANNONDALE C2 RISER, 680X20MM, 2014 ALLOY	CANNONDALE C3 RISER, 680X20MM, 6061 ALLOY	CANNONDALE C3 RISER, 680X20MM, 6061 ALLOY	CANNONDALE C3 RISER, 680X20MM, 6061 ALLOY
GRIPS	CANNONDALE ALLOY LOCKING GRIPS W/CLOSED END	CANNONDALE ALLOY LOCKING GRIPS W/CLOSED END	CANNONDALE ALLOY LOCKING GRIPS W/CLOSED END	CANNONDALE ALLOY LOCKING GRIPS W/CLOSED END	CANNONDALE ALLOY LOCKING GRIPS W/CLOSED END
STEM	CANNONDALE OPI ADJUSTABLE, -5 DEGREE, 31.8	CANNONDALE C1 HEADSHOK, 31.8	CANNONDALE C4, 1.5", 31.8, 7 DEGREE	CANNONDALE C4, 1.5", 31.8, 7 DEGREE	CANNONDALE C4, 1.5", 31.8, 7 DEGREE
HEADSET	HEADSHOK	CANNONDALE HEADSHOK SI	TANGE CUSTOM 1.5"	TANGE CUSTOM 1.5"	TANGE CUSTOM 1.5"
BRAKES	AVID ELIXIR 7, 160/140MM	AVID ELIXIR 1, 160/160MM	AVID ELIXIR 1, 160/160MM	TEKTRO DRACO PRO HYDRAULIC, 160/160MM	CANNONDALE HELIX 6 HYDRAULIC DISC, 160/160MM
BRAKE LEVERS	AVID ELIXIR 7, 160/140MM	AVID ELIXIR 1	AVID ELIXIR 1	TEKTRO DRACO PRO HYDRAULIC	CANNONDALE HELIX 6 HYDRAULIC
SADDLE	FI'ZI-K TUNDRA2 OE	CANNONDALE STAGE 2	CANNONDALE STAGE 2	CANNONDALE STAGE 2	CANNONDALE STAGE 2
SEATPOST	CANNONDALE C2, 31.6X400MM	CANNONDALE C3, 27.2X400MM	CANNONDALE C3, 31.6X350MM (S, M) 400MM (L, X, J)	CANNONDALE C3, 31.6X350MM (S, M) 400MM (L, X, J)	CANNONDALE C3, 31.6X350MM (S, M) 400MM (L, X, J)
SIZES	S, M, L, X	S, M, L, X	S, M, L, X, J	S, M, L, X, J	S, M, L, X, J
COLOR 1 (CODE)	RACE RED W/MAGNESIUM WHITE AND JET BLACK ACCENTS (GLOSS) (RED)	JET BLACK (GLOSS) (BLK)	JET BLACK (GLOSS) (BLK2)	JET BLACK (MATTE) (BBQ)	CHARCOAL GREY (MATTE) (GRY)
COLOR 2 (CODE)		MAGNESIUM WHITE W/BERSERKER GREEN ACCENTS (GLOSS) (GRN)	RACE RED (GLOSS) (RED)	MAGNESIUM WHITE (GLOSS) (WHT)	MAGNESIUM WHITE (GLOSS) (WHT)

	TRAIL 5	TRAIL 6	SCALPEL 29'ER CARBON 1	SCALPEL 29'ER CARBON 2	SCALPEL 29'ER ALLOY 3
CODE	ZFT5	ZFT6	ZVP91	ZVP92	ZVP93
FRAME	TRAIL, DOUBLE BUTTED 6061 ALLOY, SAVE, 1-1/8" HEAD TUBE	TRAIL, DOUBLE BUTTED 6061 ALLOY, SAVE, 1-1/8" HEAD TUBE	SCALPEL 29'ER, 100MM, BALLISTEC HI-MOD FULL CARBON, ZERO PIVOT SEATSTAY, BB30, 1.5 SI HEAD TUBE	SCALPEL 29'ER, 100MM, BALLISTEC HI-MOD FULL CARBON, ZERO PIVOT SEATSTAY, BB30, 1.5 SI HEAD TUBE	SCALPEL 29'ER, 100MM, SMARTFORMED ALLOY, BB30, 1.5 SI HEAD TUBE
FORK	RST BLAZE PRO TNL, 100MM, COIL/ELASTOMER, LOCKOUT, 1-1/8"	RST BLAZE T, 100MM, COIL/ELASTOMER, 1-1/8"	LEFTY 29'ER CARBON XLR, 100MM, OPI, SOLO AIR	LEFTY 29'ER XLR, 100MM, OPI, SOLO AIR	LEFTY 29'ER PBR, 100MM, OPI, SOLO AIR
REAR SHOCK	N/A	N/A	FOX RP23	ROCKSHOX MONARCH RT3	FOX RP2
RIMS	ALEX DC4.5, DOUBLE WALL, 32 HOLE	ALEX DC4.5, DOUBLE WALL, 32 HOLE	DT SWISS TRICON 1550 29'ER LEFTY, TUBELESS READY	STAN'S ZTR ARCH 29'ER, 32 HOLE	SUNRINGLE INFERNO25, WELDED, WEYELET, 32 HOLE
HUBS	CANNONDALE C4, FRONT & REAR	CANNONDALE C4, FRONT & REAR	DT SWISS TRICON 1550 29'ER LEFTY	LEFTY SL FRONT, SUNRINGLE DIRTY FLEA REAR 142X12MM REAR	LEFTY SL FRONT, FORMULA DHL-142 142X12MM REAR
SPOKES	STAINLESS STEEL, 15G, BLACK	STAINLESS STEEL, 15G, BLACK	DT SWISS TRICON 1550 29'ER LEFTY	DT SWISS COMPETITION	DT SWISS COMPETITION
TIRES	KENDA SMALL BLOCK 8, 2.1"	KENDA SMALL BLOCK 8, 2.1"	SCHWALBE RACING RALPH EVO, 2.25" TUBELESS READY	SCHWALBE RACING RALPH EVO, 2.25" TUBELESS READY	SCHWALBE RACING RALPH EVO, 2.25" TUBELESS READY
PEDALS	FPD PLATFORM, PLASTIC BODY	FPD PLATFORM, PLASTIC BODY	N/A	N/A	N/A
CRANK	SHIMANO, FC-M311, 42/32/22, 170MM (S), 175MM (M-J)	SHIMANO, FC-M131, 42/34/24	CANNONDALE HOLLOWGRAM SL, BB30, 39/26 W/XX CHAINRINGS	SRAM S2210, BB30, 39/26	SRAM S1000, BB30, 39/26
BOTTOM BRACKET	TANGE SEIKI LN-3912	TANGE SEIKI LN-3912	SRAM PRESSFIT BB30	SRAM BB30	SRAM BB30
CHAIN	KMC Z-72, 8-SPEED	KMC Z-72, 8-SPEED	KMC X10SL, 10-SPEED	KMC X10SL, 10-SPEED	KMC X10, 10-SPEED
REAR COGS	SUNRACE M66, 12-32, 8-SPEED	SUNRACE M56, 11-32, 8-SPEED	SRAM PG-1070, 11-36, 10-SPEED	SRAM PG-1070, 11-36, 10-SPEED	SRAM PG-1030, 11-36, 10-SPEED
FR. DERAILLEUR	SHIMANO FD-M310, 34.9 CLAMP	SHIMANO FD-M190, 34.9 CLAMP	SRAM X0, DIRECT MOUNT	SRAM X9, DIRECT MOUNT	SRAM X7, DIRECT MOUNT
REAR DERAILLEUR	SHIMANO ACERA	SHIMANO ACERA	SRAM XX	SHIMANO XT	SRAM X9
SHIFTERS	SHIMANO ACERA	SHIMANO M-310	SRAM XX	SHIMANO XT	SRAM X7
HANDLEBAR	CANNONDALE C4 RISER, 660X30MM, 6061 ALLOY	CANNONDALE C4 RISER, 660X30MM, 6061 ALLOY	TRUVATIV NOIR FLAT, 700X10MM	TRUVATIV NOIR FLAT, 700X10MM	CANNONDALE C2 FLAT, 680X3MM, 2014 ALLOY
GRIPS	CANNONDALE DUAL DENSITY GRIPS	CANNONDALE DUAL DENSITY GRIPS	CANNONDALE ALLOY LOCKING GRIPS W/CLOSED END	CANNONDALE ALLOY LOCKING GRIPS W/CLOSED END	CANNONDALE ALLOY LOCKING GRIPS W/CLOSED END
STEM	CANNONDALE C4, 31.8, 7 DEGREE	CANNONDALE C4, 31.8, 7 DEGREE	CANNONDALE OPI ADJUSTABLE, -15 DEGREE, 31.8	CANNONDALE OPI ADJUSTABLE, -15 DEGREE, 31.8	CANNONDALE C1 HEADSHOK, 31.8
HEADSET	TANGE SEIKI ER2 SLIM STACK	TANGE SEIKI ER2 SLIM STACK	CANNONDALE HEADSHOK SI	CANNONDALE HEADSHOK SI	CANNONDALE HEADSHOK SI
BRAKES	PROMAX MECHANICAL DISC, 160/160MM	TEKTRO NOVELA MECHANICAL DISC, 160/160MM	AVID ELIXIR X0, 180/160MM	AVID ELIXIR 9 CARBON, 180/160MM	AVID ELIXIR 5, 180/160MM
BRAKE LEVERS	CANNONDALE	CANNONDALE	AVID ELIXIR X0	AVID ELIXIR 9 CARBON	AVID ELIXIR 5
SADDLE	CANNONDALE STAGE 2	CANNONDALE STAGE 2	FI'ZI-K TUNDRA2 KM	FI'ZI-K TUNDRA2 OE	FI'ZI-K TUNDRA2 OE
SEATPOST	CANNONDALE C4, 31.6X350MM (S, M) 400MM (L, X, J)	CANNONDALE C4, 31.6X350MM (S, M) 400MM (L, X, J)	FI'ZI-K CYRANO, 31.6X400MM	FI'ZI-K CYRANO, 31.6X400MM	CANNONDALE C3, 31.6X400MM
SIZES	S, M, L, X, J	S, M, L, X, J	S, M, L, X	S, M, L, X	S, M, L, X
COLOR 1 (CODE)	INDIGO BLUE (GLOSS) (BLU)	JET BLACK (MATTE) (BBQ)	EXPOSED CARBON W/MAGNESIUM WHITE AND CHARCOAL GREY (MATTE) (BBQ)	EXPOSED CARBON W/MAGNESIUM WHITE AND BERSERKER GREEN (GLOSS) (BLK)	MAGNESIUM WHITE (GLOSS) (WHT)
COLOR 2 (CODE)	FINE SILVER (GLOSS) (SLV)	MAGNESIUM WHITE (GLOSS) (WHT)			

	SCALPEL 29'ER ALLOY 4	FLASH 29'ER CARBON ULTIMATE	FLASH 29'ER CARBON 1	FLASH 29'ER CARBON 2	FLASH 29'ER CARBON 3
CODE	ZVP94	ZFS290S	ZFS291S	ZFS292S	ZFS293S
FRAME	SCALPEL 29'ER, 100MM, SMARTFORMED ALLOY, BB30, 1.5 SI HEAD TUBE	FLASH 29'ER, BALLISTEC HI-MOD CARBON, SPEED SAVE, BB30 1.5 SI HEAD TUBE	FLASH 29'ER, BALLISTEC HI-MOD CARBON, SPEED SAVE, BB30 1.5 SI HEAD TUBE	FLASH 29'ER, BALLISTEC CARBON, SPEED SAVE, BB30 1.5 SI HEAD TUBE	FLASH 29'ER, BALLISTEC CARBON, SPEED SAVE, BB30 1.5 SI HEAD TUBE
FORK	LEFTY SPEED PBR, 100MM, OPI, SOLO AIR	ROCKSHOX RECON GOLD TK 29, 80MM, SOLO AIR, LOCKOUT, REBOUND, 1.5"	LEFTY 29'ER CARBON XLR, 90MM, OPI, SOLO AIR	LEFTY 29'ER CARBON XLR, 90MM, OPI, SOLO AIR	LEFTY 29'ER PBR, 100MM, OPI, SOLO AIR
REAR SHOCK	X FUSION E1 RL	N/A	N/A	N/A	N/A
RIMS	SUNRINGLE INFERNO25, WELDED, WEYELET, 29'ER, 32 HOLE	ENVE COMPOSITES TWENTY9 XC, 28 HOLE FRONT, 32 HOLE REAR	STAN'S ZTR ARCH 29'ER, 32 HOLE	STAN'S ZTR ARCH 29'ER, 32 HOLE	SUNRINGLE INFERNO25, WELDED, WEYELET, 29'ER, 32 HOLE
HUBS	FORMULA 20MM FRONT, 142X12MM REAR	LEFTY SL FRONT, DT SWISS 240S REAR	LEFTY SL FRONT, DT SWISS 240S REAR	LEFTY SL FRONT, DT SWISS 240S REAR	LEFTY SL FRONT, SRAM X9 REAR
SPOKES	DT SWISS CHAMPION	DT SWISS AEROLITE	DT SWISS COMPETITION	DT SWISS COMPETITION	DT SWISS COMPETITION
TIRES	KENDA SMALL BLOCK 8, 2.1" FOLDING	SCHWALBE RACING RALPH EVO, 2.1" TUBELESS READY	SCHWALBE RACING RALPH EVO, 2.1" TUBELESS READY	SCHWALBE RACING RALPH EVO, 2.1" TUBELESS READY	SCHWALBE RACING RALPH EVO, 2.1" TUBELESS READY
PEDALS	N/A	N/A	N/A	N/A	N/A
CRANK	FSA COMET, BB30, 42/32/24	CANNONDALE HOLLOWGRAM SL, BB30, 39/26 W/SRAM XX RINGS	SRAM S2210, BB30, 39/26	SRAM S2210, BB30, 39/26	SRAM S1400, BB30, 39/26
BOTTOM BRACKET	FSA BB30	CANNONDALE BB30	SRAM BB30	SRAM BB30	SRAM BB30
CHAIN	KMC X10, 10-SPEED	KMC X10SL, 10-SPEED	KMC X10SL, 10-SPEED	KMC X10SL, 10-SPEED	KMC X10SL, 10-SPEED
REAR COGS	SRAM XX, 11-36, 10-SPEED	SRAM XX, 11-36, 10-SPEED	SRAM PG-1070, 11-36, 10-SPEED	SRAM PG-1070, 11-36, 10-SPEED	SRAM PG-1030, 11-36, 10-SPEED
FR. DERAILLEUR	SHIMANO DEORE, DIRECT MOUNT	SRAM XX, DIRECT MOUNT	SRAM X0, DIRECT MOUNT	SRAM X9, DIRECT MOUNT	SRAM X7, DIRECT MOUNT
REAR DERAILLEUR	SHIMANO XT	SRAM XX	SHIMANO XTR	SHIMANO XT	SHIMANO XT
SHIFTERS	SHIMANO DEORE	SHIMANO DEORE	SHIMANO XTR	SHIMANO XT	SHIMANO XT
HANDLEBAR	CANNONDALE C3 RISER, 680X20MM, 6061	ENVE COMPOSITES SWEEP, 700X0MM	TRUVATIV NOIR FLAT, 700X10MM	TRUVATIV NOIR FLAT, 700X10MM	CANNONDALE C2 FLAT, 680X3MM, 2014 ALLOY
GRIPS	CANNONDALE ALLOY LOCKING GRIPS W/CLOSED END	CANNONDALE FOAM LOCKING GRIPS	CANNONDALE FOAM LOCKING GRIPS	CANNONDALE FOAM LOCKING GRIPS	CANNONDALE ALLOY LOCKING GRIPS W/CLOSED END
STEM	CANNONDALE C3, 1.5", 31.8	CANNONDALE OPI ADJUSTABLE, -15 DEGREE, 31.8	CANNONDALE OPI ADJUSTABLE, -15 DEGREE, 31.8	CANNONDALE OPI ADJUSTABLE, -15 DEGREE, 31.8	CANNONDALE OPI ADJUSTABLE, -15 DEGREE, 31.8
HEADSET	TANGE 1.5 SI	CANNONDALE HEADSHOK SI	CANNONDALE HEADSHOK SI	CANNONDALE HEADSHOK SI	CANNONDALE HEADSHOK SI
BRAKES	AVID ELIXIR 3, 180/160MM	SRAM XX WORLD CUP 160/140MM	AVID X0 CARBON, 180/160MM	AVID ELIXIR 9 CARBON, 180/160MM	AVID ELIXIR 9, 180/16

MOUNTAIN SPECIFICATIONS

	FLASH 29'ER ALLOY 1
CODE	2FA291
FRAME	FLASH 29'ER, SMARTFORMED ALLOY, SPEED SAVE, BB30, 1.5 SI HEAD TUBE
FORK	LEFTY 29'ER PBR, 90MM, OPI, SOLO AIR
REAR SHOCK	N/A
RIMS	SUNRINGLE INFERNO25, WELDED, W/EYELET, 29'ER, 32 HOLE
HUBS	LEFTY SL FRONT, SRAM X9 REAR
SPOKES	DT SWISS COMPETITION
TIRES	SCHWALBE RAPID ROB, 2.25"
PEDALS	N/A
CRANK	SRAM S1400, BB30, 39/26
BOTTOM BRACKET	SRAM BB30
CHAIN	KMC X10SL, 10-SPEED
REAR COGS	SRAM PG-1030, 11-36, 10-SPEED
FR. DERAILLEUR	SRAM X7
REAR DERAILLEUR	SRAM X9
SHIFTERS	SRAM X9
HANDLEBAR	CANNONDALE C2 FLAT, 680X3MM, 2014 ALLOY
GRIPS	CANNONDALE ALLOY LOCKING GRIPS W/CLOSED END
STEM	CANNONDALE OPI ADJUSTABLE, -15 DEGREE, 31.8
HEADSET	CANNONDALE HEADSHOK SI
BRAKES	AVID ELIXIR 7, 180/160MM
BRAKE LEVERS	AVID ELIXIR 7
SADDLE	CANNONDALE STAGE 2
SEATPOST	CANNONDALE C2, 27.2X400MM
SIZES	M, L, X
COLOR 1 (CODE)	JET BLACK (MATTE) (BBQ)
COLOR 2 (CODE)	

	FLASH 29'ER ALLOY 2
CODE	2FA292
FRAME	FLASH 29'ER, SMARTFORMED ALLOY, SPEED SAVE, BB30, 1.5 SI HEAD TUBE
FORK	LEFTY 29'ER PBR, 90MM, OPI, SOLO AIR
REAR SHOCK	N/A
RIMS	SUNRINGLE INFERNO25, WELDED, W/EYELET, 29'ER, 32 HOLE
HUBS	LEFTY FRONT, FORMULA DC22 REAR
SPOKES	DT SWISS CHAMPION
TIRES	SCHWALBE RAPID ROB, 2.25"
PEDALS	N/A
CRANK	SRAM S1000, BB30, 44/33/22
BOTTOM BRACKET	SRAM BB30
CHAIN	KMC X10, 10-SPEED
REAR COGS	SRAM PG-1030, 11-36, 10-SPEED
FR. DERAILLEUR	SRAM X7
REAR DERAILLEUR	SRAM X9
SHIFTERS	SRAM X7
HANDLEBAR	CANNONDALE C3 RISER, 680X20MM, 6061
GRIPS	CANNONDALE ALLOY LOCKING GRIPS W/CLOSED END
STEM	CANNONDALE C1 HEADSHOK, 31.8
HEADSET	CANNONDALE HEADSHOK SI
BRAKES	AVID ELIXIR 3, 180/160MM
BRAKE LEVERS	AVID ELIXIR 3
SADDLE	CANNONDALE STAGE 2
SEATPOST	CANNONDALE C2, 27.2X400MM
SIZES	M, L, X
COLOR 1 (CODE)	MAGNESIUM WHITE (GLOSS) (WHT)
COLOR 2 (CODE)	

	FLASH 29'ER ALLOY 3
CODE	2FA293
FRAME	FLASH 29'ER, SMARTFORMED ALLOY, SPEED SAVE, BB30, 1.5 SI HEAD TUBE
FORK	ROCKSHOX RECON GOLD TK 29, 80MM, SOLO AIR, LOCKOUT, REBOUND, 1.5"
REAR SHOCK	N/A
RIMS	MADDEX DC3.0 29'ER, DOUBLE WALL, W/ EYELET, 32 HOLE
HUBS	FORMULA DC20 FRONT, DC22 REAR
SPOKES	STAINLESS STEEL, BLACK, 15G
TIRES	SCHWALBE RAPID ROB, 2.25"
PEDALS	FPD ALLOY PLATFORM
CRANK	SHIMANO M552, 42/32/24
BOTTOM BRACKET	INCLUDED
CHAIN	KMC X10, 10-SPEED
REAR COGS	SRAM PG-1030, 11-36, 10-SPEED
FR. DERAILLEUR	SHIMANO DEORE
REAR DERAILLEUR	SHIMANO SLX
SHIFTERS	SHIMANO SLX
HANDLEBAR	CANNONDALE C3 RISER, 680X20MM, 6061
GRIPS	CANNONDALE ALLOY LOCKING GRIPS W/CLOSED END
STEM	CANNONDALE C3, 1.5", 31.8
HEADSET	TANGE 1.5 CUSTOM
BRAKES	AVID ELIXIR 1, 180/160MM
BRAKE LEVERS	AVID ELIXIR 1
SADDLE	CANNONDALE STAGE 2
SEATPOST	CANNONDALE C2, 27.2X400MM
SIZES	M, L, X
COLOR 1 (CODE)	JET BLACK (GLOSS) (BLK)
COLOR 2 (CODE)	

	TRAIL SL 29'ER 2
CODE	2FS292
FRAME	TRAIL SL 29'ER, OPTIMIZED 6061 ALLOY, SAVE, 1.5" HEAD TUBE
FORK	ROCKSHOX RECON SILVER TK 29, 80MM, SOLO AIR, LOCKOUT, REBOUND, 1.5"
REAR SHOCK	N/A
RIMS	MADDEX DC3.0 29'ER, DOUBLE WALL W/EYELET, 32 HOLE
HUBS	FORMULA CDH20 FRONT, FORMULA CDH22 REAR
SPOKES	STAINLESS STEEL, BLACK, 15G
TIRES	KENDA SMALL BLOCK 8, 29X2.1"
PEDALS	FPD PLATFORM, PLASTIC BODY
CRANK	SRAM S800 3.1, 44/33/22, 175MM (M, L, X)
BOTTOM BRACKET	SRAM POWERSPLINE
CHAIN	KMC X10, 10-SPEED
REAR COGS	SHIMANO HG-62, 11-36, 10-SPEED
FR. DERAILLEUR	SRAM X5, 34.9 CLAMP
REAR DERAILLEUR	SRAM X5, 10-SPEED
SHIFTERS	SRAM X5
HANDLEBAR	CANNONDALE C3 RISER, 680X20MM, 6061 ALLOY
GRIPS	CANNONDALE ALLOY LOCKING GRIPS W/CLOSED END
STEM	CANNONDALE C4, 1.5", 31.8, 7 DEGREE
HEADSET	TANGE 1.5 CUSTOM
BRAKES	AVID ELIXIR 1, 160/160MM
BRAKE LEVERS	AVID ELIXIR 1
SADDLE	CANNONDALE STAGE 2
SEATPOST	CANNONDALE C3, 31.6X350 (S, M), 400MM (L, X)
SIZES	S, M, L, X
COLOR 1 (CODE)	JET BLACK (MATTE) (BBQ)
COLOR 2 (CODE)	MAGNESIUM WHITE (GLOSS) (WHT)

	TRAIL SL 29'ER 3
CODE	2FS293
FRAME	TRAIL SL 29'ER, OPTIMIZED 6061 ALLOY, SAVE, 1.5" HEAD TUBE
FORK	RST DEUCE COIL 29, 80MM, LOCKOUT, REBOUND, 1.5"
REAR SHOCK	N/A
RIMS	MADDEX DC3.0 29'ER, DOUBLE WALL W/EYELET, 32 HOLE
HUBS	CANNONDALE C4 FRONT, C4 REAR
SPOKES	STAINLESS STEEL, BLACK, 15G
TIRES	KENDA SMALL BLOCK 8, 29X2.1"
PEDALS	FPD PLATFORM, PLASTIC BODY
CRANK	SHIMANO FC-M430-8, 44/33/22, 175MM (M, L, X)
BOTTOM BRACKET	SHIMANO ES-25, OCTALINK
CHAIN	SHIMANO HG53, 9-SPEED
REAR COGS	SHIMANO HG53, 12-36, 9-SPEED
FR. DERAILLEUR	SHIMANO ALIVIO, SRAM X5, 34.9 CLAMP
REAR DERAILLEUR	SHIMANO DEORE, SHADOW
SHIFTERS	SHIMANO ALIVIO
HANDLEBAR	CANNONDALE C3 RISER, 680X20MM, 6061 ALLOY
GRIPS	CANNONDALE ALLOY LOCKING GRIPS W/CLOSED END
STEM	CANNONDALE C4, 1.5", 31.8, 7 DEGREE
HEADSET	TANGE 1.5 CUSTOM
BRAKES	SHIMANO M446, 160/160MM
BRAKE LEVERS	SHIMANO M446
SADDLE	CANNONDALE STAGE 2
SEATPOST	CANNONDALE C2, 2014 ALLOY, 2 BOLT, ALLOY, 31.6X350MM (S, M), 400MM (L, X)
SIZES	S, M, L, X
COLOR 1 (CODE)	VINTAGE MOSS (GLOSS) (GRN)
COLOR 2 (CODE)	RACE RED (GLOSS) (RED)

	TRAIL SL 29'ER 3R
CODE	2FS293R
FRAME	TRAIL SL 29'ER, OPTIMIZED 6061 ALLOY, SAVE, 1.5" HEAD TUBE
FORK	CANNONDALE FATTY RIGID 29'ER
RIMS	MADDEX DC3.0 29'ER, DOUBLE WALL W/EYELET, 32 HOLE
HUBS	CANNONDALE C4 FRONT, FORMULA DC52
SPOKES	STAINLESS STEEL, BLACK, 15G
TIRES	KENDA SMALL BLOCK 8, 29X2.1"
PEDALS	FPD PLATFORM, PLASTIC BODY
CRANK	TRUVATIV ISOFLOW 1.0G SS, 33T
BOTTOM BRACKET	TANGE SEIKI LN-3912
CHAIN	KMC Z-99 SS
REAR COGS	FORMULA, 20T
FR. DERAILLEUR	N/A
REAR DERAILLEUR	N/A
SHIFTERS	N/A
HANDLEBAR	CANNONDALE C3 RISER, 680X20MM, 6061 ALLOY
GRIPS	CANNONDALE ALLOY LOCKING GRIPS W/ CLOSED END
STEM	CANNONDALE C4, 1.5", 31.8, 7 DEGREE
HEADSET	TANGE 1.5 CUSTOM
BRAKES	PROMAX MECHANICAL DISC, 160/160MM
BRAKE LEVERS	CANNONDALE
SADDLE	CANNONDALE STAGE 2
SEATPOST	CANNONDALE C3, 31.6X350 (S, M), 400MM (L, X)
SIZES	S, M, L, X
COLOR 1 (CODE)	JET BLACK (GLOSS) (BLK)
COLOR 2 (CODE)	

	TRAIL SL 29'ER 4
CODE	2FS294
FRAME	TRAIL SL 29'ER, OPTIMIZED 6061 ALLOY, SAVE, 1.5" HEAD TUBE
FORK	RST DEUCE 29 TNL, 80MM, COIL/ELASTOMER, HYDRAULIC LOCKOUT, 1.5"
REAR SHOCK	ALEX DC4.5 29'ER, DOUBLE WALL, 32 HOLE
RIMS	ALEX DC4.5 29'ER, DOUBLE WALL, 32 HOLE
HUBS	CANNONDALE C4 FRONT, C4 REAR
SPOKES	STAINLESS STEEL, BLACK, 15G
TIRES	KENDA SMALL BLOCK 8, 29X2.1"
PEDALS	FPD PLATFORM, PLASTIC BODY
CRANK	SHIMANO FC-M361, 42/32/22
BOTTOM BRACKET	TANGE SEIKI LN-3912
CHAIN	SHIMANO HG40, 8-SPEED
REAR COGS	SUNRACE M66, 12-32, 8-SPEED
FR. DERAILLEUR	SHIMANO ALTUS, 34.9 CLAMP
REAR DERAILLEUR	SHIMANO ALIVIO
SHIFTERS	SHIMANO ALTUS
HANDLEBAR	CANNONDALE C3 RISER, 680X20MM, 6061 ALLOY
GRIPS	CANNONDALE ALLOY LOCKING GRIPS W/CLOSED END
STEM	CANNONDALE C4, 1.5", 31.8, 7 DEGREE
HEADSET	TANGE 1.5 CUSTOM
BRAKES	CANNONDALE HELIX 6 HYDRAULIC DISC, 160/160MM
BRAKE LEVERS	CANNONDALE HELIX 6 HYDRAULIC DISC
SADDLE	CANNONDALE STAGE 2
SEATPOST	CANNONDALE C3, 31.6X350 (S, M), 400MM (L, X)
SIZES	S, M, L, X
COLOR 1 (CODE)	JET BLACK (GLOSS) (BLK)
COLOR 2 (CODE)	SAFFRON METALLIC (MATTE) (ORG)

	TRAIL SL 29'ER 5
CODE	2FS295
FRAME	TRAIL SL 29'ER, OPTIMIZED 6061 ALLOY, SAVE, 1.5" HEAD TUBE
FORK	RST DEUCE 29 TNL, 80MM, COIL/ELASTOMER, HYDRAULIC LOCKOUT, 1.5"
REAR SHOCK	ALEX DC4.5 29'ER, DOUBLE WALL, 32 HOLE
RIMS	ALEX DC4.5 29'ER, DOUBLE WALL, 32 HOLE
HUBS	CANNONDALE C4 FRONT, C4 REAR
SPOKES	STAINLESS STEEL, BLACK, 15G
TIRES	KENDA SMALL BLOCK 8, 29X2.1"
PEDALS	FPD PLATFORM, PLASTIC BODY
CRANK	SHIMANO FC-M311, 42/32/22, 175MM (M, L, X)
BOTTOM BRACKET	TANGE SEIKI LN-3912
CHAIN	SHIMANO HG40, 8-SPEED
REAR COGS	SUNRACE M66, 12-32, 8-SPEED
FR. DERAILLEUR	SHIMANO ALTUS, 34.9 CLAMP
REAR DERAILLEUR	SHIMANO ACERA
SHIFTERS	SHIMANO ALTUS
HANDLEBAR	CANNONDALE C3 RISER, 680X20MM, 6061 ALLOY
GRIPS	CANNONDALE ALLOY LOCKING GRIPS W/CLOSED END
STEM	CANNONDALE C4, 1.5", 31.8, 7 DEGREE
HEADSET	TANGE 1.5 CUSTOM
BRAKES	PROMAX MECHANICAL DISC, 160/160MM
BRAKE LEVERS	CANNONDALE
SADDLE	CANNONDALE STAGE 2
SEATPOST	CANNONDALE C3, 31.6X350 (S, M), 400MM (L, X)
SIZES	S, M, L, X
COLOR 1 (CODE)	NIAGRA BLUE (GLOSS) (BLU)
COLOR 2 (CODE)	MAGNESIUM WHITE (GLOSS) (WHT)

	TRAIL SL 29'ER 6
CODE	2FS296
FRAME	TRAIL SL 29'ER, OPTIMIZED 6061 ALLOY, SAVE, 1.5" HEAD TUBE
FORK	RST DEUCE 29 TNL, 80MM, COIL/ELASTOMER, HYDRAULIC LOCKOUT, 1.5"
REAR SHOCK	ALEX DC4.5 29'ER, DOUBLE WALL, 32 HOLE
RIMS	ALEX DC4.5 29'ER, DOUBLE WALL, 32 HOLE
HUBS	CANNONDALE C4 FRONT, C4 REAR
SPOKES	STAINLESS STEEL, BLACK, 15G
TIRES	KENDA SMALL BLOCK 8, 29X2.1"
PEDALS	FPD PLATFORM, PLASTIC BODY
CRANK	SHIMANO FC-M311, 42/32/22, 175MM (M, L, X)
BOTTOM BRACKET	TANGE SEIKI LN-3912
CHAIN	SHIMANO HG40, 8-SPEED
REAR COGS	SUNRACE M66, 12-32, 8-SPEED
FR. DERAILLEUR	SHIMANO ALTUS, 34.9 CLAMP
REAR DERAILLEUR	SHIMANO ACERA
SHIFTERS	SHIMANO ALTUS
HANDLEBAR	CANNONDALE C3 RISER, 680X20MM, 6061 ALLOY
GRIPS	CANNONDALE ALLOY LOCKING GRIPS W/CLOSED END
STEM	CANNONDALE C4, 1.5", 31.8, 7 DEGREE
HEADSET	TANGE 1.5 CUSTOM
BRAKES	PROMAX MECHANICAL DISC, 160/160MM
BRAKE LEVERS	CANNONDALE
SADDLE	CANNONDALE STAGE 2
SEATPOST	CANNONDALE C3, 31.6X350 (S, M), 400MM (L, X)
SIZES	S, M, L, X
COLOR 1 (CODE)	NIAGRA BLUE (GLOSS) (BLU)
COLOR 2 (CODE)	MAGNESIUM WHITE (GLOSS) (WHT)

RECREATION / URBAN SPECIFICATIONS

	BAD BOY 1
CODE	2B81
FRAME	BAD BOY STEALTH, OPTIMIZED 6061 ALLOY, HEADSHOK
FORK	HEADSHOK SOLO DL50, 50MM W/LOCKOUT, OPI
RIMS	MADDEX C2 URBAN SL, 32 HOLE
HUBS	CANNONDALE LEFTY SL FRONT, SHIMANO M525 DEORE REAR
SPOKES	STAINLESS XD BLACK, 15G
TIRES	SCHWALBE KOJAK RACE GUARD, 700X28C
PEDALS	CANNONDALE URBAN 6POINT3 ALLOY PLATFORM
CRANK	SHIMANO M431, BAD BOY, 48/36/26
BOTTOM BRACKET	TANGE CARTRIDGE, JIS
CHAIN	KMC Z99 BLACK, 9-SPEED
REAR COGS	SUNRACE CSM969, BAD BOY, 11-32, 9-SPEED
FR. DERAILLEUR	SHIMANO ALIVIO, 34.9 MM CLAMP
REAR DERAILLEUR	SHIMANO SLX
SHIFTERS	SHIMANO DEORE
HANDLEBAR	CANNONDALE SI URBAN OPI STEM/HANDLEBAR, 620 MM
GRIPS	CANNONDALE CITYSCAPE URBAN LOCK-ON BLACK CHROME
STEM	CANNONDALE SI URBAN OPI STEM/HANDLEBAR, 7 DEG.
HEADSET	CANNONDALE HEADSHOK SI
BRAKES	MAGURA MT2 HYDRAULIC DISC, 160/160MM
BRAKE LEVERS	MAGURA MT2 HYDRAULIC DISC
SADDLE	CANNONDALE BAD BOY URBAN
SEATPOST	CANNONDALE C2, 2 BOLT, ALLOY, 31.6X350MM
SIZES	S, M, L, X
COLOR 1 (CODE)	JET BLACK W/REFLECTIVE DECALS (MATTE) (BBQ)
COLOR 2 (CODE)	
EXTRAS	

	BAD BOY 5
CODE	2B85
FRAME	BAD BOY URBAN, MECHANICALLY FORMED 6061 ALLOY, 70DC
FORK	CANNONDALE SOLO RIGID, OPI 1.5" STEERER
RIMS	MADDEX SR300
HUBS	CANNONDALE LEFTY BY FORMULA FRONT, FORMULA DC22, 6 BOLT DISC REAR
SPOKES	STAINLESS XD BLACK, 15G
TIRES	SCHWALBE KOJAK RACE GUARD, 700X28C
PEDALS	WELLGO PLATFORM
CRANK	SHIMANO M431, 48/36/26 CUSTOM BAD BOY
BOTTOM BRACKET	TANGE CARTRIDGE, JIS
CHAIN	KMC Z99 BLACK, 9-SPEED
REAR COGS	SUNRACE CSM969, BAD BOY, 11-32, 9-SPEED
FR. DERAILLEUR	SHIMANO ALIVIO, 34.9 MM CLAMP
REAR DERAILLEUR	SHIMANO DEORE M592
SHIFTERS	SHIMANO ALVIO
HANDLEBAR	CANNONDALE SI URBAN OPI STEM/HANDLEBAR, 620 MM
GRIPS	CANNONDALE CITYSCAPE URBAN LOCK-ON BLACK CHROME
STEM	CANNONDALE SI URBAN OPI STEM/HANDLEBAR, 7 DEG.
HEADSET	TANGE CUSTOM SI 1 1/8"
BRAKES	SHIMANO M445 HYDRAULIC DISC
BRAKE LEVERS	SHIMANO M445
SADDLE	CANNONDALE BAD BOY URBAN
SEATPOST	CANNONDALE C4 6061 ALLOY, 31.6X350MM
SIZES	S, M, L, X
COLOR 1 (CODE)	JET BLACK W/REFLECTIVE DECALS (MATTE) (BBQ)
COLOR 2 (CODE)	
EXTRAS	

	BAD BOY 9
CODE	2B89
FRAME	BAD BOY, OPTIMIZED 6061 ALLOY, 1-1/8" HEAD TUBE
FORK	CANNONDALE FATTY RIGID, 1-1/8" STEERER
RIMS	MADDEX C3 URBAN, 32 HOLE
HUBS	CANNONDALE C4 FRONT AND REAR
SPOKES	STAINLESS XD BLACK, 15G
TIRES	SCHWALBE KOJAK RACE GUARD, 700X28C
PEDALS	WELLGO PLATFORM
CRANK	SHIMANO M171, 48/38/28
BOTTOM BRACKET	TANGE CARTRIDGE, JIS
CHAIN	SHIMANO HG40 BLACK, 8-SPEED
REAR COGS	SUNRACE CSM668, 11-32, BAD BOY, 8-SPEED
FR. DERAILLEUR	SHIMANO ALTUS, 34.9 MM CLAMP
REAR DERAILLEUR	SHIMANO ALVIO
SHIFTERS	SHIMANO M310 RAPIDFIRE PLUS
HANDLEBAR	CANNONDALE C4 ALLOY, FLAT, 620MM
GRIPS	CANNONDALE CITYSCAPE URBAN LOCK-ON BLACK CHROME
STEM	CANNONDALE C4, 6 DEG, 31.8
HEADSET	TANGE SI 1-1/8"
BRAKES	TEKTRO NOVELA MECHANICAL DISC, 160/160MM
BRAKE LEVERS	CANNONDALE C4
SADDLE	CANNONDALE BAD BOY URBAN
SEATPOST	CANNONDALE C4, ALLOY, 31.6X350MM
SIZES	S, M, L, X
COLOR 1 (CODE)	JET BLACK W/REFLECTIVE DECALS (MATTE) (BBQ)
COLOR 2 (CODE)	
EXTRAS	

	HOOLIGAN 1
CODE	2HL1
FRAME	NEW HOOLIGAN DELTA V, URBAN COMPACT, 20" WHEEL, 1.5 SI HEAD TUBE
FORK	CANNONDALE SOLO RIGID, OPI, 1.5" STEERER
RIMS	CANNONDALE DC3.0, 20", 32 HOLE
HUBS	CANNONDALE LEFTY SL FRONT, SHIMANO NEXUS 3-SPEED, CENTERLOCK DISC REAR
SPOKES	STAINLESS XD BLACK, 15G
TIRES	KENDA QUEST, 20 X 1.5"
PEDALS	CANNONDALE URBAN 6POINT3 ALLOY
CRANK	FSA VERO, SINGLE RING, DUAL ALLOY CHAINGUARD, 48T
BOTTOM BRACKET	CANNONDALE TP148 ECCENTRIC, TANGE CARTRIDGE, JIS
CHAIN	KMC Z72
REAR COGS	SHIMANO 16T
FR. DERAILLEUR	N/A
REAR DERAILLEUR	N/A
SHIFTERS	SHIMANO NEXUS REVO 3-SPEED
HANDLEBAR	CANNONDALE URBAN 6061, 620MM
GRIPS	CANNONDALE CITYSCAPE URBAN LOCK-ON GRIPS

RECREATION / URBAN SPECIFICATIONS

	QUICK 5
CODE	ZQR5
FRAME	QUICK, BUTTED 6061 ALLOY, SAVE
FORK	QUICK, 6061 ALLOY, 1-1/8" STEERER
RIMS	CANNONDALE C4, DOUBLE WALL, 32 HOLE
HUBS	CANNONDALE C4
SPOKES	STAINLESS, 15G
TIRES	KENDA KWICK TRAX, 700X32C
PEDALS	QUICK REINFORCED COMPOSITE W/KRATON INSERTS
CRANK	SHIMANO M131, 48/38/28
BOTTOM BRACKET	TANGE CARTRIDGE
CHAIN	KMC 8-SPEED
REAR COGS	SUNRACE CSM668, 11-32, 8-SPEED
FR. DERAILLEUR	SHIMANO M191, 31.8 CLAMP
REAR DERAILLEUR	SHIMANO ALTUS
SHIFTERS	SHIMANO M310 RAPIDFIRE PLUS
HANDLEBAR	CANNONDALE C4, 6061 ALLOY, 25MM RISE, 620MM
GRIPS	CANNONDALE ERGO PERFORMANCE.
STEM	CANNONDALE C4, 31.8, 12 DEG.
HEADSET	TANGE SI
BRAKES	CANNONDALE C4 MINI V
BRAKE LEVERS	CANNONDALE C3 W/KRATON
SADDLE	CANNONDALE QUICK ERGO PERFORMANCE
SEATPOST	CANNONDALE C4, 6061 ALLOY, 27.2X350MM
SIZES	S, M, L, X, J
COLOR 1 (CODE)	FINE SILVER (GLOSS) (SLV)
COLOR 2 (CODE)	

	QUICK CX 1
CODE	ZQRX1
FRAME	QUICK CX HEADSHOK, OPTIMIZED 6061 ALLOY, SAVE
FORK	HEADSHOK FATTY DL50, 50 MM W/LOCKOUT, OPI
RIMS	MADDUX DC3.0, DOUBLE WALL W/EYELET, 32 HOLE
HUBS	SHIMANO DEORE M595 CENTERLOCK DISC
SPOKES	STAINLESS STEEL, XD BLACK W/ RED NIPPLES, 15G
TIRES	CONTINENTAL DOUBLE FIGHTER II, 700X37C
PEDALS	CANNONDALE PLATFORM, REINFORCED RESIN BODY
CRANK	SHIMANO M521, 48/36/26
BOTTOM BRACKET	SHIMANO BB-ES25, OCTALINK
CHAIN	KMC Z99, 9-SPEED
REAR COGS	SHIMANO HG30, 11-32, 9-SPEED
FR. DERAILLEUR	SHIMANO ALIVIO
REAR DERAILLEUR	SHIMANO SLX
SHIFTERS	SHIMANO DEORE
HANDLEBAR	CANNONDALE C3, 6061 DOUBLE BUTTED, 20MM RISE, 620MM
GRIPS	CANNONDALE URBAN ERGO LOCK-ON
STEM	CANNONDALE C3 HEADSHOK, 3-D FORGED, 31.8, 12 DEG
HEADSET	TANGE SI HEADSHOK
BRAKES	SHIMANO M505 HYDRAULIC DISC, 160/160MM
BRAKE LEVERS	SHIMANO M505 HYDRAULIC DISC
SADDLE	CANNONDALE QUICK CX
SEATPOST	CANNONDALE C3, 2 BOLT, 2014 ALLOY, 31.6X350MM
SIZES	S, M, L, X, J
COLOR 1 (CODE)	BRUSHED ALUMINUM (GLOSS) (RAW)
COLOR 2 (CODE)	

	QUICK CX 2
CODE	ZQRX2
FRAME	QUICK CX , OPTIMIZED 6061 ALLOY, SAVE, 1.5" HEAD TUBE
FORK	RST NEON PRO CUSTOM 1.5" TREKKING, TNL LOCKOUT, 50MM
RIMS	MADDUX DC3.0, DOUBLE WALL W/EYELET, 32 HOLE
HUBS	SHIMANO M435 ALIVIO CENTERLOCK DISC
SPOKES	STAINLESS STEEL, XD BLACK W/RED NIPPLES, 15G
TIRES	CONTINENTAL DOUBLE FIGHTER II, 700X37C
PEDALS	CANNONDALE PLATFORM, REINFORCED RESIN BODY
CRANK	SHIMANO M431, 48/36/26
BOTTOM BRACKET	TANGE SEIKI CARTRIDGE
CHAIN	KMC Z99, 9-SPEED
REAR COGS	SHIMANO HG30, 11-32, 9-SPEED
FR. DERAILLEUR	SHIMANO ALIVIO
REAR DERAILLEUR	SHIMANO DEORE
SHIFTERS	SHIMANO ALIVIO
HANDLEBAR	CANNONDALE C3, 6061 DOUBLE BUTTED, 20MM RISE, 620MM
GRIPS	CANNONDALE URBAN ERGO LOCK-ON
STEM	CANNONDALE C3, 1.5", 3-D FORGED, 31.8, 12 DEG
HEADSET	TANGE CUSTUM 1.5"
BRAKES	SHIMANO M446 HYDRAULIC DISC, 160/160MM
BRAKE LEVERS	SHIMANO M446 HYDRAULIC DISC
SADDLE	CANNONDALE QUICK CX ERGO
SEATPOST	CANNONDALE C3, 2 BOLT, 2014 ALLOY, 31.6X350MM
SIZES	S, M, L, X, J
COLOR 1 (CODE)	JET BLACK (GLOSS) (BLK)
COLOR 2 (CODE)	

	QUICK CX 3
CODE	ZQRX3
FRAME	QUICK CX , OPTIMIZED 6061 ALLOY, SAVE, 1.5" HEAD TUBE
FORK	RST NEON PRO CUSTOM 1.5" TREKKING ML LOCKOUT 50MM
RIMS	MADDUX DC3.0, DOUBLE WALL W/EYELET, 32 HOLE
HUBS	CANNONDALE C4
SPOKES	STAINLESS STEEL, XD BLACK W/RED NIPPLES, 15G
TIRES	CONTINENTAL DOUBLE FIGHTER II, 700X37C
PEDALS	CANNONDALE PLATFORM, REINFORCED RESIN BODY
CRANK	SHIMANO M171, 48/38/28
BOTTOM BRACKET	TANGE SEIKI CARTRIDGE
CHAIN	KMC Z82, 8-SPEED
REAR COGS	SUNRACE CSG66, 11-32, 8-SPEED
FR. DERAILLEUR	SHIMANO M191
REAR DERAILLEUR	SHIMANO ALIVIO
SHIFTERS	SHIMANO ACERA
HANDLEBAR	CANNONDALE C4, 6061, 25MM RISE, 620MM
GRIPS	CANNONDALE URBAN ERGO LOCK-ON
STEM	CANNONDALE C3, 1.5", 3-D FORGED, 31.8, 12 DEG
HEADSET	TANGE CUSTOM 1.5"
BRAKES	TEKTRO NOVELA MECHANICAL DISC, 160/160MM
BRAKE LEVERS	CANNONDALE C4
SADDLE	CANNONDALE QUICK CX ERGO
SEATPOST	CANNONDALE C4, ALLOY, 31.6X350MM
SIZES	S, M, L, X, J
COLOR 1 (CODE)	MAGNESIUM WHITE (GLOSS) (WHT)
COLOR 2 (CODE)	

	QUICK CX 4
CODE	ZQRX4
FRAME	QUICK CX RIGID, OPTIMIZED 6061 ALLOY, SAVE, 1-1/8" HEAD TUBE
FORK	FATTY RIGID DISC
RIMS	MADDUX DC3.0, DOUBLE WALL W/EYELET, 32 HOLE
HUBS	CANNONDALE C4
SPOKES	STAINLESS STEEL XD BLACK, 15G
TIRES	CONTINENTAL DOUBLE FIGHTER II, 700X37C
PEDALS	CANNONDALE PLATFORM, REINFORCED RESIN BODY
CRANK	SHIMANO M-171 48/38/28
BOTTOM BRACKET	TANGE SEIKI CARTRIDGE
CHAIN	KMC Z82, 8-SPEED
REAR COGS	SUNRACE CSG66, 11-32, 8-SPEED
FR. DERAILLEUR	SHIMANO M191
REAR DERAILLEUR	SHIMANO ACERA
SHIFTERS	SHIMANO ALTUS
HANDLEBAR	CANNONDALE C4, 6061, 25MM RISE, 620MM
GRIPS	CANNONDALE URBAN ERGO
STEM	CANNONDALE C4, 1-1/8", 31.8, 12 DEG
HEADSET	TANGE 1-1/8"
BRAKES	TEKTRO NOVELA MECHANICAL DISC, 160/160MM
BRAKE LEVERS	CANNONDALE C4
SADDLE	CANNONDALE QUICK CX ERGO
SEATPOST	CANNONDALE C4, ALLOY, 31.6X350MM
SIZES	S, M, L, X, J
COLOR 1 (CODE)	JET BLACK (GLOSS) (BLK)
COLOR 2 (CODE)	

	ADVENTURE 2
CODE	2AS2
FRAME	ADVENTURE, DOUBLE BUTTED 6061 ALLOY
FORK	ADVENTURE TRAIL SI SUSPENSION, 35MM, 1-1/8" STEERER
RIMS	CANNONDALE C3, DOUBLE WALL, 32 HOLE
HUBS	CANNONDALE C4
SPOKES	STAINLESS, 14G
TIRES	KENDA KWICK TRAX, 700X38C
PEDALS	FPD PLATFORM W/KRATON INSERTS
CRANK	SHIMANO M311, 48/38/28
BOTTOM BRACKET	TANGE CARTRIDGE
CHAIN	KMC 8-SPEED
REAR COGS	SUNRACE CSM66, 11-32, 8-SPEED
FR. DERAILLEUR	SHIMANO M-191
REAR DERAILLEUR	SHIMANO ALIVIO
SHIFTERS	SHIMANO REVO TWIST TYPE
HANDLEBAR	CANNONDALE C4, 50MM RISE, ALLOY, 620MM
GRIPS	CANNONDALE ERGO LOCK-ON GRIPS
STEM	TRANZ X COMFORT GRIP, TOOL-FREE ADJUSTMENT
HEADSET	TANGE SEMI INTEGRATED
BRAKES	CANNONDALE V BRAKE W/MODULATOR
BRAKE LEVERS	CANNONDALE, 4 FINGER W/KRATON COMFORT INSERT
SADDLE	CANNONDALE ULTRA COMFORT
SEATPOST	CANNONDALE SUSPENSION, 40MM TRAVEL, 27.2X350MM
SIZES	S, M, L, X, J
COLOR 1 (CODE)	JET BLACK (GLOSS) (BLK2)
EXTRAS	

	ADVENTURE 3
CODE	2AS3
FRAME	ADVENTURE, DOUBLE BUTTED 6061 ALLOY
FORK	RST SOFI T 50MM, 1-1/8" STEERER
RIMS	CANNONDALE C3, DOUBLE WALL, 32 HOLE
HUBS	CANNONDALE C4
SPOKES	STAINLESS, 14G
TIRES	KENDA KWICK TRAX, 700X38C
PEDALS	FPD PLATFORM W/KRATON INSERTS
CRANK	SHIMANO M131, 48/38/28
BOTTOM BRACKET	TANGE CARTRIDGE
CHAIN	KMC 8-SPEED
REAR COGS	SUNRACE CSM66, 11-32, 8-SPEED
FR. DERAILLEUR	SHIMANO M-191
REAR DERAILLEUR	SHIMANO ACERA
SHIFTERS	SHIMANO REVO TWIST TYPE
HANDLEBAR	CANNONDALE C4, 50MM RISE, ALLOY, 620MM
GRIPS	CANNONDALE ERGO LOCK-ON GRIPS
STEM	TRANZ X COMFORT GRIP, TOOL-FREE ADJUSTMENT, QUILL TYPE
HEADSET	TANGE SEMI INTEGRATED
BRAKES	CANNONDALE V BRAKE W/MODULATOR
BRAKE LEVERS	CANNONDALE, 4 FINGER W/KRATON COMFORT INSERT
SADDLE	CANNONDALE ULTRA COMFORT
SEATPOST	CANNONDALE SUSPENSION, 40MM TRAVEL, 27.2X350MM
SIZES	S, M, L, X, J
COLOR 1 (CODE)	INDIGO BLUE (GLOSS) (BLU)
EXTRAS	

	ADVENTURE 3 26"
CODE	2CS3
FRAME	ADVENTURE 26", DOUBLE BUTTED 6061 ALLOY
FORK	RST SOFI T 26", 50MM, 1-1/8" STEERER
RIMS	CANNONDALE C3, DOUBLE WALL, 26", 32 HOLE
HUBS	CANNONDALE C4
SPOKES	STAINLESS, 14G
TIRES	KENDA K1052, 26 X 2.1"
PEDALS	FPD PLATFORM W/KRATON INSERTS
CRANK	SHIMANO M131, 48/38/28
BOTTOM BRACKET	TANGE CARTRIDGE
CHAIN	KMC 8-SPEED
REAR COGS	SUNRACE CSM66, 11-32, 8-SPEED
FR. DERAILLEUR	SHIMANO M-191
REAR DERAILLEUR	SHIMANO ACERA
SHIFTERS	SHIMANO REVO TWIST TYPE
HANDLEBAR	CANNONDALE C4, 50MM RISE, ALLOY, 620MM
GRIPS	CANNONDALE ERGO LOCK-ON GRIPS
STEM	TRANZ X COMFORT GRIP, TOOL-FREE ADJUSTMENT, QUILL TYPE
HEADSET	TANGE SEMI INTEGRATED
BRAKES	CANNONDALE V BRAKE W/MODULATOR
BRAKE LEVERS	CANNONDALE, 4 FINGER W/KRATON COMFORT INSERT
SADDLE	CANNONDALE ULTRA COMFORT
SEATPOST	CANNONDALE SUSPENSION, 40MM TRAVEL, 27.2X350MM
SIZES	S, M, L, X, J
COLOR 1 (CODE)	INDIGO BLUE (GLOSS) (BLU)
EXTRAS	

	ROAD TANDEM 2
CODE	9RT2
FRAME	CAAD TANDEM, OPTIMIZED, 6061 ALLOY, 700C
FORK	FATTY R TANDEM RIGID, 1-1/8" STEERER
RIMS	SUN ME14A W/EYELET AND MACHINED SIDEWALL, 40 HOLE
HUBS	WHITE INDUSTRIES M16 DISC
SPOKES	DT SWISS CHAMPION, 14G
TIRES	CONTINENTAL ULTRA GATORSKIN, 700X28C
PEDALS	N/A
CRANK	FSA GOSSAMER TANDEM, 53/39/30
BOTTOM BRACKET	TANGE MEGAEXO
CHAIN	SHIMANO 105, 115, KMC 8-SPEED TIMING
REAR COGS	IRD, 11-32, 10-SPEED
FR. DERAILLEUR	SHIMANO ULTEGRA 6700
REAR DERAILLEUR	SHIMANO ULTEGRA 6700
SHIFTERS	SHIMANO ULTEGRA 6700, 10-SPEED
HANDLEBAR	FSA GOSSAMER, 31.8 FRONT, STOKER REAR
GRIPS	CANNONDALE 3MM SUEDE W/GEL BACKING BAR TAPE
STEM	CANNONDALE C3 FRONT, 31.8 STOKER REAR
HEADSET	TANGE INTEGRATED
BRAKES	AVID BB7 ROAD DISC
BRAKE LEVERS	SHIMANO ULTEGRA 6700
SADDLE	FI'ZI-K ALJANTE DELTA MG
SEATPOST	THOMSON ELITE 27.2X410, CANNONDALE C2 316X400
SIZES	M/S, L/S, X/S, J/M
COLOR 1 (CODE)	LIGHTNING WHITE (GLOSS) (WHT)
EXTRAS	

ROAD GEOMETRY

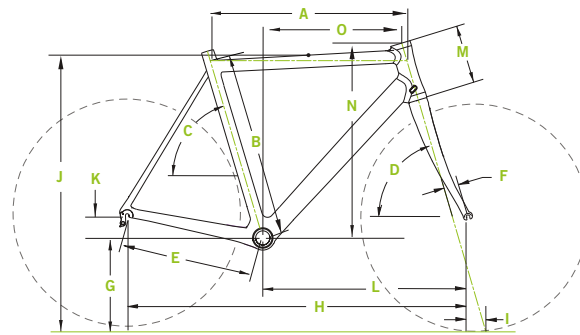

	SUPERSIX EVO & SUPERSIX								
	SPECIFICATIONS								
A	HORIZONTAL TOP TUBE LENGTH (CM)	51.5	52.5	53.5	54.5	56	57.5	59	60
B	MEASURED SIZE (CM)*	46	48	50	52	54	56	58	61
C	SEAT TUBE ANGLE (DEGREES)	74.5	74.5	74	73.5	73.5	73	72.5	72
D	HEAD TUBE ANGLE (DEGREES)	71.5	72.0	72.5	73	73	73.5	73.5	73.5
E	CHAIN STAY LENGTH (CM)	40.5	★	★	★	★	★	★	40.8 40.8
F	FORK RAKE (CM)	4.5	★	★	★	★	★	★	★
G	BOTTOM BRACKET HEIGHT (CM)	26.5	26.5	26.5	26.8	26.8	27	27	27
H	WHEELBASE (CM)	96.1	96.7	97.3	97.5	99.1	99.6	100.8	101.2
I	TRAIL (CM)	6.6	6.3	6.0	5.7	5.7	5.4	5.4	5.4
J	STANDOVER AT TOP TUBE MIDPOINT (CM)	74.2	75.5	76.7	78.8	80.4	82.5	84.3	86.9
K	BOTTOM BRACKET DROP (CM)	7.2	7.2	7.2	6.9	6.9	6.7	6.7	6.7
L	FRONT CENTER DISTANCE (CM)	56.3	56.9	57.5	57.6	59.1	59.7	60.6	60.9
M	HEAD TUBE LENGTH (CM)	11	11.5	12	14	15.5	17.5	19.5**	22
N	STACK (CM)	51.3	51.9	52.6	54.4	55.8	57.7	59.6***	62.0
O	REACH (CM)	36.8	37.6	38.4	38.4	39.5	39.9	40.2	39.9

* THE MEASURED SIZE IS FROM THE CENTER OF THE BOTTOM BRACKET TO THE TOP OF THE TOP TUBE, MEASURED ALONG THE SEAT TUBE AXIS.
 ** SIZE 60 EVO HAS A HEAD TUBE LENGTH OF 13.5 WHILE FOR SUPER SIX THE LENGTH IS 19
 *** SIZE 60 EVO HAS A STACK OF 59.6 WHILE FOR SUPER SIX THE STACK IS 59.3

CAAD10

	SPECIFICATIONS								
A	HORIZONTAL TOP TUBE LENGTH (CM)	51.5	52.5	53.5	54.5	56.0	57.5	59.0	60.0
B	MEASURED SIZE (CM)*	46	48	50	52	54	56	58	61
C	SEAT TUBE ANGLE (DEGREES)	74.5	74.5	74	73.5	73.5	73	72.5	72
D	HEAD TUBE ANGLE (DEGREES)	72	72.5	73	73	73.5	73.5	73.5	73.5
E	CHAIN STAY LENGTH (CM)	40.5	40.5	40.8	★	★	★	★	★
F	FORK RAKE (CM)	5	★	★	★	4.5	★	★	★
G	BOTTOM BRACKET HEIGHT (CM)	2							

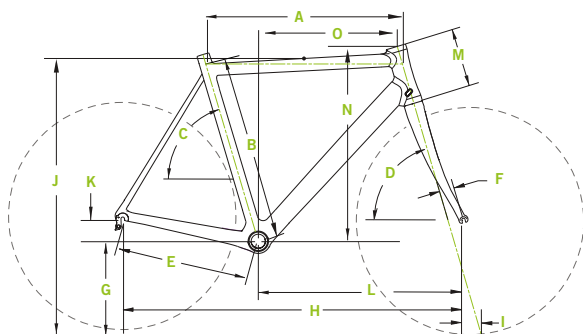

SLICE

SUPERX

CAADX

SPECIFICATIONS	51	54	56	58	60
A HORIZONTAL TOP TUBE LENGTH (CM)	50.5	53.5	55	56.5	58
B MEASURED SIZE (CM)*	50	51.5	53.5	55.5	57.5
C SEAT TUBE ANGLE (DEGREES)	*VARIABLE	VARIABLE	VARIABLE	VARIABLE	VARIABLE
D HEAD TUBE ANGLE (DEGREES)	71.5	71.5	72	72	72
E CHAIN STAY LENGTH (CM)	40	40	40	40	40
F FORK RAKE (CM)	4.5	4.5	4.5	4.5	4.5
G BOTTOM BRACKET HEIGHT (CM)	26.5	26.5	26.5	26.5	26.5
H WHEELBASE (CM)	95.4	98.5	99.7	101.3	102.6
I TRAIL (CM)	6.5	6.5	6.2	6.2	6.2
J STANDOVER AT TOP TUBE MIDPOINT (CM)	74.9	76.4	78.3	80.2	82.2
K BOTTOM BRACKET DROP (CM)	7.2	7.2	7.2	7.2	7.2
L FRONT CENTER DISTANCE (CM)	56.5	59.6	60.7	62.3	63.9
M HEAD TUBE LENGTH (CM)	9	10.5	12.5	14.5	17
N STACK (CM)	**49.4	50.9	52.9	54.8	57.2
O REACH (CM)	**37.1	39.8	40.7	41.7	42.5

SPECIFICATIONS	44	48	52	54	56	58
A HORIZONTAL TOP TUBE LENGTH (CM)	51	52	54	55	57	59
B MEASURED SIZE (CM)*	44	48	52	54	56	58
C SEAT TUBE ANGLE (DEGREES)	75	74	73.5	73.5	73	73
D HEAD TUBE ANGLE (DEGREES)	69	69.5	71.5	72	72.5	72.5
E CHAIN STAY LENGTH (CM)	43	★	★	★	★	★
F FORK RAKE (CM)	4.5	★	★	★	★	★
G BOTTOM BRACKET HEIGHT (CM)	28.1	★	★	★	★	★
H WHEELBASE (CM)	101.7	101.4	101.1	101.7	102.6	104.7
I TRAIL (CM)	8.5	8.4	7.0	6.7	6.4	6.4
J STANDOVER AT TOP TUBE MIDPOINT (CM)	74.9	77.0	80.4	82.2	83.6	85.5
K BOTTOM BRACKET DROP (CM)	6.7	★	★	★	★	★
L FRONT CENTER DISTANCE (CM)	59.6	59.3	59.0	59.6	60.5	62.6
M HEAD TUBE LENGTH (CM)	10	11	13.5	15	16	18
N STACK (CM)	51.8	52.9	56.0	57.6	58.8	60.7
O REACH (CM)	37.1	36.8	37.4	37.9	39.0	40.5

SPECIFICATIONS	44	48	51	54	56	58	61
A HORIZONTAL TOP TUBE LENGTH (CM)	51.5	52.5	53.5	54.5	56.0	57.5	59.0
B MEASURED SIZE (CM)*	44	47	50	53	55	57	60
C SEAT TUBE ANGLE (DEGREES)	75	74.5	74	73.5	73	73	72.5
D HEAD TUBE ANGLE (DEGREES)	69.5	70.5	71	72	72.5	72.5	72.5
E CHAIN STAY LENGTH (CM)	43.2	43.2	43.2	43.2	43.2	43.2	43.2
F FORK RAKE (CM)	5	★	★	★	★	★	★
G BOTTOM BRACKET HEIGHT (CM)	28.3	★	★	★	★	★	★
H WHEELBASE (CM)	101.8	101.3	101.6	102.3	103.3	105.4	105.8
I TRAIL (CM)	7.7	7.0	6.7	6.0	5.7	5.7	5.7
J STANDOVER AT TOP TUBE MIDPOINT (CM)	75.5	77.7	79.8	81.9	83.0	85.0	87.3
K BOTTOM BRACKET DROP (CM)	6.7	★	★	★	★	★	★
L FRONT CENTER DISTANCE (CM)	59.5	59.0	59.3	60.0	61.0	63.0	63.5
M HEAD TUBE LENGTH (CM)	12	13.0	14.5	15.5	16.0	18.0	20.0
N STACK (CM)	53.8	55.1	56.7	58.0	58.7	60.6	62.5
O REACH (CM)	36.2	36.2	36.4	37.7	39.0	40.4	40.3

* THE SLICE SEAT POST HAS TWO POSITIONS FOR MOUNTING THE SADDLE. A FULL RANGE OF ANGLES FROM 73 TO 78 DEGREES IS ACHIEVABLE DEPENDING ON THE RIDER'S PREFERENCE AND/OR THE EVENT.
 ** STACK IS MEASURED VERTICALLY FROM THE CENTER OF THE BB TO THE TOP OF THE HEAD TUBE. REACH IS MEASURED HORIZONTALLY FROM THE CENTER OF THE BB TO THE TOP OF THE HEAD TUBE. IF YOU RIDE A 56 ROAD FRAME, YOU SHOULD CHOOSE A SIZE 56 SLICE FRAME.
 ALL SIZES HAVE 700C WHEELS.

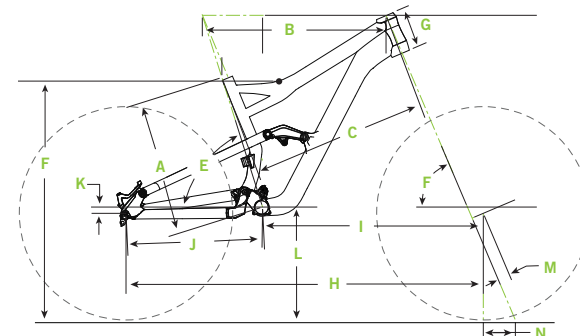

CLAYMORE

SPECIFICATIONS	SMALL	MEDIUM	LARGE	X-LARGE
A SEAT TUBE LENGTH (CM/IN)	39.5/15.6	43.0/16.9	47.0/18.5	51.0/20.1
B TOP TUBE HORIZONTAL (CM/IN)	54.9/21.6	58.2/22.9	61.1/24.1	64.3/25.3
C TOP TUBE ACTUAL (CM/IN)	52.9/20.8	55.6/21.9	58.2/22.9	61.3/24.1
D HEAD TUBE ANGLE HI BB	66.5°	67.0°	67.0°	67.0°
E HEAD TUBE ANGLE LOW BB	65.5°	66°	66°	66°
F SEAT TUBE ANGLE EFFECTIVE	73.0°	72.6°	72.1°	71.8°
G STANDOVER HI BB (CM/IN)	73.7/29.0	75.6/29.8	78.2/30.8	80.7/31.8
H STANDOVER LOW BB (CM/IN)	72.6/28.6	74.5/29.3	77.1/30.3	79.6/31.3
I HEAD TUBE LENGTH (CM/IN)	11.5/4.5	13.0/5.1	14.0/5.5	15.0/5.9
J WHEELBASE (CM/IN)	110.9/43.7	113.2/44.6	115.7/45.6	118.5/46.7
K FRONT CENTER (CM/IN)	67.6/26.6	69.9/27.5	72.4/28.5	75.2/29.6
L CHAIN STAY LENGTH (CM/IN)	43.3/17.0	★	★	★
M BOTTOM BRACKET DROP HI BB (CM/IN)	2.0/0.8	★	★	★
N BOTTOM BRACKET DROP LOW BB (CM/IN)	0.8/0.3	★	★	★
O BOTTOM BRACKET HEIGHT HI BB (CM/IN)	35.8/14.1	★	★	★
P BOTTOM BRACKET HEIGHT LOW BB (CM/IN)	34.6/13.6	★	★	★
Q FORK RAKE (CM/IN)	3.9/1.5	★	★	★
R TRAIL (CM/IN)	10.5/4.1	10.2/4.0	10.2/4.0	10.2/4.0

JEKYLL CARBON / JEKYLL ALLOY

SPECIFICATIONS	SMALL	MEDIUM	LARGE	X-LARGE
A SEAT TUBE LENGTH (CM/IN)	43.2/17.0	45.7/18.0	48.3/19.0	50.8/20.0
B TOP TUBE HORIZONTAL (CM/IN)	55.6/21.9	58.8/23.1	61.4/24.2	64.2/25.3
C TOP TUBE ACTUAL (CM/IN)	53.4/21.0	56.4/22.2	59.1/23.3	61.8/24.3
D HEAD TUBE ANGLE	67.7°	67.8°	67.9°	68.0°
E SEAT TUBE ANGLE EFFECTIVE	73.6°	★	★	73.5°
F STANDOVER (CM/IN)	75.2/29.6	75.3/29.6	76.4/30.1	77.7/30.6
G HEAD TUBE LENGTH (CM/IN)	13.4/5.3	★	★	16.0/6.3
H WHEELBASE (CM/IN)	110.0/43.3	113.1/44.5	115.5/45.5	118.4/46.6
I FRONT CENTER (CM/IN)	67.2/26.5	70.3/27.7	72.7/28.6	75.6/29.8
J CHAIN STAY LENGTH (CM/IN)	42.8/16.9	★	★	★
K BOTTOM BRACKET DROP (CM/IN)	1.2/0.5	★	★	★
L BOTTOM BRACKET HEIGHT (CM/IN)	35.0/13.8	★	★	★
M FORK RAKE (CM/IN)	4.0/1.6	★	★	★
N TRAIL (CM/IN)	9.5/3.8	9.5/3.8	9.4/3.7	9.3/3.7

RZ ONE-TWENTY

SPECIFICATIONS	SMALL	MEDIUM	LARGE	X-LARGE
A SEAT TUBE LENGTH (CM/IN)	43.2/17.0	45.7/18.0	48.3/19.0	50.9/20.0
B TOP TUBE HORIZONTAL (CM/IN)	56.0/22.0	58.7/23.1	61.3/24.1	64.1/25.2
C TOP TUBE ACTUAL (CM/IN)	53.5/21.1	56.2/22.1	59.1/23.3	61.9/24.4
D HEAD TUBE ANGLE	69.0°	★	★	★
E SEAT TUBE ANGLE EFFECTIVE	73.5°	★	★	★
F STANDOVER (CM/IN)	73.1/28.8	76.0/29.9	76.1/30.0	76.0/29.9
G HEAD TUBE LENGTH - (CM/IN)	13.4/5.3	★	★	16.0/6.3
H WHEELBASE (CM/IN)	107.6/42.4	110.3/43.4	113.0/44.5	116.0/45.7
I FRONT CENTER (CM/IN)	65.2/25.7	67.8/26.7	70.5/27.8	73.5/28.9
J CHAIN STAY LENGTH (CM/IN)	42.5/16.7	★	★	★
K BOTTOM BRACKET DROP (CM/IN)	0.0/0.0	★	★	★
L BOTTOM BRACKET HEIGHT (CM/IN)	33.0/13.0	★	★	★
M FORK RAKE (CM/IN)	4.5/1.8	★	★	★
N TRAIL (CM/IN)	7.8/3.1	★	★	★

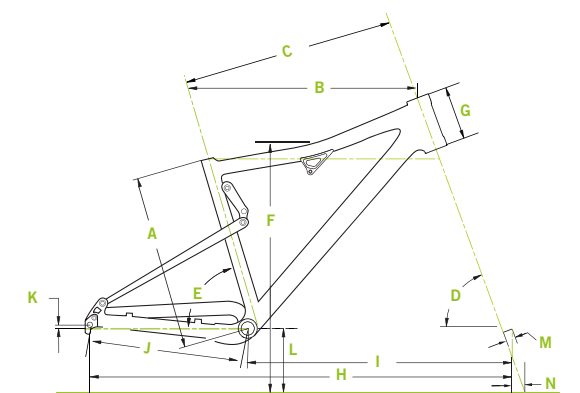
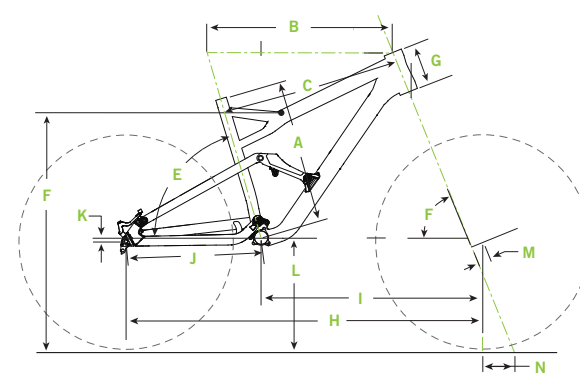

⚠️ WARNINGS!

Bicycling has risks of serious injury or death that cannot be completely avoided. Risk can be minimized by: Reading and following all warnings and instructions in owner's manuals, owner's manual supplements, always wearing a helmet, practice and step-by-step learning, riding in control and within your capabilities.

Catalog text and descriptions are marketing materials, not instructions or guidelines for use!

Visit <http://www.cannondale.com/bikes/tech/safety> for warnings, technical documents, and safety guidelines.

Warning: Reflectors are not a substitute for proper lights. It is your responsibility to equip your bicycle with all state and locally mandated lights. Riding at dawn, at dusk, at night or at other times of poor visibility without a bicycle lighting system which meets local and state laws and without reflectors is dangerous and may result in serious injury or death.

If you ride your bike before dawn or after dusk, your bicycle must be equipped with lights so that you can see the road and avoid road hazards, and so that others can see you. Traffic laws treat

bicycles like any other vehicle. That means you must have a white front and a red rear light operating if you are riding after dusk. Your bike dealer can recommend a battery or generator powered lighting system appropriate to your needs.

Cannondale also strongly urges you to use a flashing light or strobe. All of us at Cannondale who ride at night or in conditions of lower visibility use flashers. They can save your life

Please note: Despite our nagging, members of the Liquigas pro road racing team (and other professional sponsored teams) may appear or race without helmets. We don't think it's a good idea, but they are experienced, professional cyclists and they know the risks. They are also adults, so we respect their right to choose. Despite the intransigence of any teams, we strongly advocate the use of helmets on every ride. Wearing a helmet is perhaps your single best defense against a major medical catastrophe while riding, so buckle up!

Warning: Free riding is inherently dangerous. Read Free ride Warning at <http://www.cannondale.com/bikes/tech/safety.html>

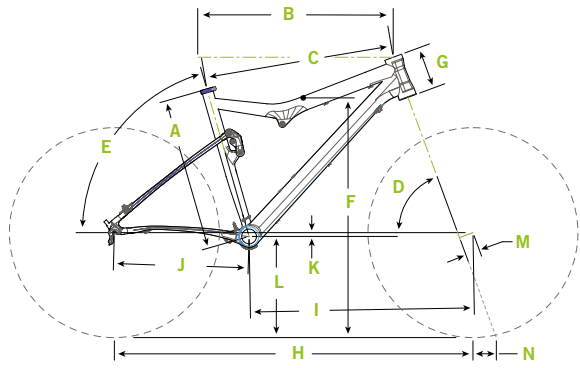

SCALPEL

SPECIFICATIONS	SMALL	MEDIUM	LARGE	X-LARGE
A SEAT TUBE LENGTH (CM/IN)	40.5/15.9	43.5/17.1	48.2/19.0	53.2/20.9
B TOP TUBE HORIZONTAL (CM/IN)	55.5/21.9	58.5/23.0	61.5/24.2	64.0/25.2
C TOP TUBE ACTUAL (CM/IN)	53.4/21.0	56.2/22.1	59.5/23.4	62.7/24.7
D HEAD TUBE ANGLE	69.3	69.6	69.8	70.0
E SEAT TUBE ANGLE EFFECTIVE	74.0	★	★	★
E' SEAT TUBE ANGLE ACTUAL	-	-	-	-
F STANDOVER (CM/IN)	75.9/29.9	75.7/29.8	75.4/29.7	75.4/29.7
G HEAD TUBE LENGTH (CM/IN)	13.4/5.3	★	★	★
H WHEELBASE (CM/IN)	107.4/42.3	110.0/43.3	112.8/44.4	115.1/45.3
I FRONT CENTER (CM/IN)	65.0/25.6	67.7/26.6	70.4/27.7	72.7/28.6
J CHAIN STAY LENGTH (CM/IN)	42.4/16.7	★	★	★
K BOTTOM BRACKET DROP (CM/IN)	1.2/0.5	★	★	★
L BOTTOM BRACKET HEIGHT (CM/IN)	31.8/12.5	★	★	★
M FORK RAKE (CM/IN)	4.5/1.8	★	★	★
N TRAIL (CM/IN)	7.7/3.0	7.5/2.9	7.4/2.9	7.2/2.8

SCALPEL 29'ER CARBON

SPECIFICATIONS	SMALL	MEDIUM	LARGE	X-LARGE
A SEAT TUBE LENGTH (CM/IN)	42.0/16.5	44.5/17.5	48.5/19.1	53.5/21.1
B TOP TUBE HORIZONTAL (CM/IN)	56.9/22.4	59.3/23.3	61.7/24.3	64.1/25.2
C TOP TUBE ACTUAL (CM/IN)	53.5/21.1	55.5/21.9	57.8/22.8	60.5/23.8
D HEAD TUBE ANGLE	70.5°	71.0°	71.2°	71.4°
E SEAT TUBE ANGLE EFFECTIVE	73.5°	★	★	★
E' SEAT TUBE ANGLE ACTUAL	70.5°	★	★	★
F STANDOVER (CM/IN)	73.6/29.0	74.7/29.4	75.6/29.8	77.2/30.4
G HEAD TUBE LENGTH (CM/IN)	12.2/4.8	★	★	★
H WHEELBASE (CM/IN)	108.2/42.6	110.0/43.3	112.2/44.2	114.3/45.0
I FRONT CENTER (CM/IN)	64.0/25.2	65.9/25.9	68.0/26.8	70.2/27.6
J CHAIN STAY LENGTH (CM/IN)	44.4/17.5	★	★	★
K BOTTOM BRACKET DROP (CM/IN)	3.8/1.5	★	★	★
L BOTTOM BRACKET HEIGHT (CM/IN)	33.2/13.1	★	★	★
M FORK RAKE (CM/IN)	4.5/1.8	★	★	★
N TRAIL (CM/IN)	8.3/3.3	8.0/3.1	7.8/3.1	7.7/3.0

SCALPEL 29'ER ALLOY

SPECIFICATIONS	SMALL	MEDIUM	LARGE	X-LARGE
A SEAT TUBE LENGTH (CM/IN)	41.1/16.2	44.5/17.5	48.5/19.1	53.5/21.1
B TOP TUBE HORIZONTAL (CM/IN)	56.9/22.4	59.3/23.3	61.7/24.3	64.1/25.2
C TOP TUBE ACTUAL (CM/IN)	53.7/21.1	55.5/21.9	57.7/22.7	60.4/23.8
D HEAD TUBE ANGLE	70.5°	71.0°	71.2°	71.4°
E SEAT TUBE ANGLE EFFECTIVE	73.9°	★	★	★
E' SEAT TUBE ANGLE ACTUAL	-	-	-	-
F STANDOVER (CM/IN)	73.4/28.9	74.3/29.2	75.3/29.6	75.5/29.7
G HEAD TUBE LENGTH (CM/IN)	12.2/4.8	★	★	★
H WHEELBASE (CM/IN)	108.2/42.6	110.0/43.3	112.2/44.2	114.3/45.0
I FRONT CENTER (CM/IN)	64.0/25.2	65.9/25.9	68.0/26.8	70.2/27.6
J CHAIN STAY LENGTH (CM/IN)	44.4/17.5	★	★	★
K BOTTOM BRACKET DROP (CM/IN)	3.8/1.5	★	★	★
L BOTTOM BRACKET HEIGHT (CM/IN)	33.2/13.1	★	★	★
M FORK RAKE (CM/IN)	4.5/1.8	★	★	★
N TRAIL (CM/IN)	8.3/3.3	8.0/3.1	7.8/3.1	7.7/3.0

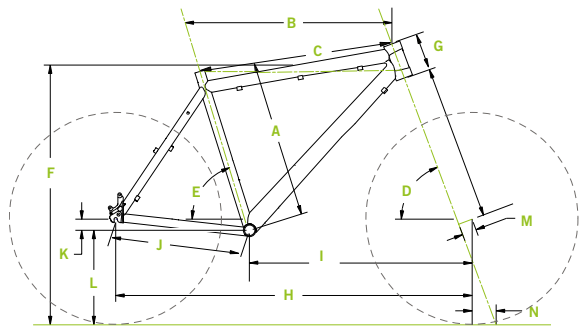

FLASH ALLOY

SPECIFICATIONS	SMALL	MEDIUM	LARGE	X-LARGE
A SEAT TUBE LENGTH (CM/IN)	38.0/15	43.3/17	47.5/18.7	52.5/20.7
B TOP TUBE HORIZONTAL (CM/IN)	55.0/21.7	58.5/23	61.4/24.2	62.9/24.8
C TOP TUBE ACTUAL (CM/IN)	53.8/21.2	56.3/22.2	58.9/23.2	60.8/23.9
D HEAD TUBE ANGLE	70.0°	★	★	★
E SEAT TUBE ANGLE EFFECTIVE	73.5°	73.5°	73.0°	72.5°
F STANDOVER AT TOP TUBE (CM/IN)	74.4/29.3	77.0/30.3	78.9/31.1	81.3/32
G HEAD TUBE LENGTH - (CM/IN)	13.4/5.3	★	★	★
H WHEELBASE (CM/IN)	104.9/41.3	108.4/42.7	110.8/43.6	111.7/44
I FRONT CENTER (CM/IN)	62.7/24.7	66.2/26.1	68.6/27	69.5/27.4
J CHAIN STAY LENGTH (CM/IN)	42.4/16.7	★	★	★
K BOTTOM BRACKET DROP (CM/IN)	3.0/1.2	★	★	★
L BOTTOM BRACKET HEIGHT (CM/IN)	29.5/11.6	★	★	★
M FORK RAKE (CM/IN)	4.5/1.8	★	★	★
N TRAIL (CM/IN)	7.0/2.8	★	★	★

FLASH 29'ER CARBON / ALLOY

SPECIFICATIONS	MEDIUM	LARGE	X-LARGE
A SEAT TUBE LENGTH (CM/IN)	43.3/17	47.5/18.7	52.5/20.7
B TOP TUBE HORIZONTAL (CM/IN)	59.3/23.3	62.2/24.5	64.1/25.2
C TOP TUBE ACTUAL (CM/IN)	57.8/22.8	59.7/23.5	61.2/24.1
D HEAD TUBE ANGLE	71.0°	71.0°	71.5°
E SEAT TUBE ANGLE EFFECTIVE	73.5°	73.0°	72.5°
F STANDOVER AT TOP TUBE (CM/IN)	80.9/31.9	82.9/32.6	85.3/33.6
G HEAD TUBE LENGTH - (CM/IN)	13.4/5.3	13.4/5.3	13.4/5.3
H WHEELBASE (CM/IN)	108.8/42.8	111.1/43.7	111.8/44
I FRONT CENTER (CM/IN)	65.2/25.7	67.5/26.6	68.2/26.9
J CHAIN STAY LENGTH (CM/IN)	44.4/17.5	★	★
K BOTTOM BRACKET DROP (CM/IN)	6.5/2.6	★	★
L BOTTOM BRACKET HEIGHT (CM/IN)	30.5/12	★	★
M FORK RAKE (CM/IN)	4.5/1.8	★	★
N TRAIL (CM/IN)	8.0/3.1	8.0/3.1	7.6/3

★ Indicates same as previous

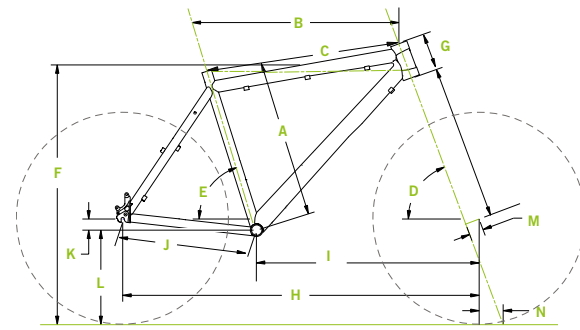

TRAIL SL / TRAIL

SPECIFICATIONS	SMALL	MEDIUM	LARGE	X-LARGE	JUMBO
A SEAT TUBE LENGTH (CM/IN)	38.0/15	43.3/17	47.5/18.7	52.5/20.7	57.0/22.4
B TOP TUBE HORIZONTAL (CM/IN)	55.0/21.7	58.4/23	61.4/24.2	62.9/24.8	63.7/25.1
C TOP TUBE ACTUAL (CM/IN)	53.9/21.2	56.3/22.2	58.9/23.2	60.4/23.8	61.7/24.3
D HEAD TUBE ANGLE	70.0°	★	★	★	★
E SEAT TUBE ANGLE EFFECTIVE	73.5°	73.5°	73.0°	72.5°	72.5°
F STANDOVER (CM/IN)	74.3/29.3	76.8/30.2	78.8/31	82.6/32.5	84.7/33.3
G HEAD TUBE LENGTH (CM/IN)	11.4/4.5	★	★	11.4/5.7	11.4/5.7
H WHEELBASE (CM/IN)	104.7/41.2	108.2/42.6	110.6/43.4	117.7/44	142.4/44.3
I FRONT CENTER (CM/IN)	62.6/24.6	62.6/24.6	62.6/24.6	62.6/24.6	62.6/24.6
J CHAIN STAY LENGTH (CM/IN)	42.4/16.7	★	★	★	★
K BOTTOM BRACKET DROP (CM/IN)	3.5/1.4	★	★	★	★
L BOTTOM BRACKET HEIGHT (CM/IN)	29.0/11.4	★	★	★	★
M FORK RAKE (CM/IN)	4.5/1.8	★	★	★	★
N TRAIL (CM/IN)	7.0/2.8	★	★	★	★

TRAIL SL 29'ER

SPECIFICATIONS	SMALL	MEDIUM	LARGE	X-LARGE
A SEAT TUBE LENGTH (CM/IN)	39.0/15.4	43.3/17	47.5/18.7	52.5/20.7
B TOP TUBE HORIZONTAL (CM/IN)	56.5/22.2	58.3/23	61.3/24.1	63.0/24.8
C TOP TUBE ACTUAL (CM/IN)	55.6/21.9	56.5/22.2	58.8/23.1	60.4/23.8
D HEAD TUBE ANGLE	70.0°	★	★	★
E SEAT TUBE ANGLE EFFECTIVE	73.5°	73.5°	73.0°	72.5°
F STANDOVER (CM/IN)	77.4/30.5	80.0/31.5	82.0/32.3	84.4/33.2
G HEAD TUBE LENGTH (CM/IN)	11.4/4.5	★	★	★
H WHEELBASE (CM/IN)	108.3/42.6	110.1/43.3	112.5/44.3	113.5/44.7
I FRONT CENTER (CM/IN)	63.5/25	65.4/25.7	67.7/26.7	68.8/27.1
J CHAIN STAY LENGTH (CM/IN)	45.4/17.9	★	★	★
K BOTTOM BRACKET DROP (CM/IN)	6.0/2.4	★	★	★
L BOTTOM BRACKET HEIGHT (CM/IN)	30.5/12	31.0/12.2	★	★
M FORK RAKE (CM/IN)	4.5/1.8	★	★	★
N TRAIL (CM/IN)	8.6/3.4	7.0/2.8	★	★

REGISTERED TRADEMARKS © OF THE CYCLING SPORTS GROUP, INC.:

Cannondale, the Cannondale "C" logo, Daytripper, Feel It, Fatty, Gemini, Jekyll, Lefty, Optimo, Perp, Prophet, Scalpel, Slice, Synapse, SystemSix, Hooligan.

TRADEMARKS ™ OF THE CYCLING SPORTS GROUP, INC.:

BB30, CAAD (Cannondale Advanced Aluminum Design), Caffeine, Capo, Chase, CO2, HeadShok, Hi-MOD, Hollowgram, Judge, Just for Women, Moto, PowerPyramid, Quick, Q-Lab, Rize, RZ, Rush, S.A.V.E., Si, SuperSix, System Integration, Taurine, The Cut, BallisTec Carbon, SmartFormed Alloy, ECS-TC (Enhanced Center-Stiffness, Torsion Control) System, Zero Pivot, Lexi, Scarlet, Cannondale Factory Racing.

Liquigas-Doimo, FSA, Mavic, Campagnolo, SRM, Speedplay, Schwalbe, Elite, Sci Con CFR: fi'zi:k, RockShox, SRAM, MET, crankbrothers, Avid, Cannondale - Cyclocrossworld.com: Zipp, Prologo, crankbrothers, TRP, Control Tech are sponsorship partners and their trademarks are used with their permission. FOX and FOX RLC are trademarks of FOX Factory Inc. and are used with their permission. Solo Air, RockShox, XLoc and PopTop are trademarks of SRAM and are used with their permission. X-12 is a trademark of Syntace GmbH and is used with their permission. EVO is a trademark of Aprebic Industry Co. Ltd. and used under license.

WWW.CANNONDALE.COM

Please visit cannondale.com to learn more about Cannondale and the 2012 bikes! Specifications subject to change without notice.

Please refer to www.cannondale.com for the most recent specifications.

NO WEIGHTS?

Don't believe the hype. Scales differ, and marketing departments have been known to fib. The best way to compare bike weights is to head to your local bike shop. Grab two comparably spec'd and built bikes, and ask the proprietor for a scale. Hang 'em high, and see who's the lightest.

SPECIAL THANKS GOES TO:

- | | |
|---|---------------------------------|
| ALE DI LULLO PHOTOGRAPHY | KYLE ARCOMANO |
| ANDREA PATERNO | LOREN SYNDER |
| BRIAN HODES/VELO IMAGES | MARCO TONIOLO |
| BRIAN VERNOR | MATTHEW DELORME |
| CHRIS MILLIMAN PHOTOGRAPHY | MIKE KARCHER/WIX PIX |
| CHRIS VANDERYAJT | NAVONE STUDIOS |
| COMPETITIVE IMAGE | REBECCA MARSHALL |
| DANNY MUNSON | RED BULL |
| DEAN "BLOTTO" GRAY | RICHARD STABLER |
| DH PRODUCTIONS | ROBERTO BETTINI PHOTO |
| EGO PROMOTION/MAASEWERD AND KUESTENBRUECK | SINCERE PHOTO AND DESIGN |
| GARDY RAYMOND | SVEN MARTIN |
| GREG GERMAIN | WIL MATTHEWS |
| HAVERKORT DEKKER FOTOGRAFIE | WTB |
| JAKE HAMM | OUR RIDERS |
| KIRSTEN BEGG-SWIDER | OUR VENDORS |
| | OUR DEALERS |
| | AND YOU FOR RIDING A CANNONDALE |

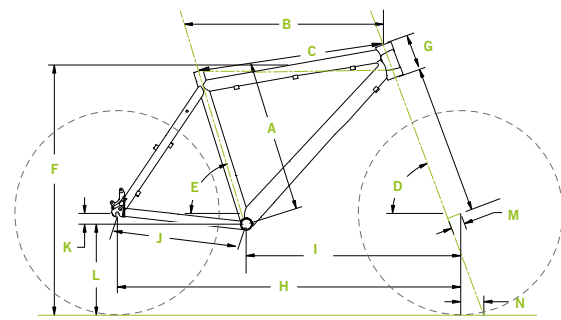

BADBOY HEADSHOK

SPECIFICATIONS	SMALL	MEDIUM	LARGE	X-LARGE
A SEAT TUBE OVERALL LENGTH (CM/IN)	39/15.4	46/18.1	51/20.1	56/22.0
B TOP TUBE HORIZONTAL (CM)	55	57.5	60	62
C TOP TUBE ACTUAL (CM/IN)	52.1/20.5	54.7/21.5	57.3/22.6	59.7/23.5
D HEAD TUBE ANGLE	70	71	★	★
E SEAT TUBE ANGLE	74.5	73.5	73	72.5
F STANDOVER HEIGHT (CM)	77	80.4	82.6	84.7
G HEAD TUBE LENGTH (CM)	11.4	★	★	★
H WHEELBASE (CM)	104.4	105.8	108.1	109.8
I FRONT CENTER (CM)	61.4	62.8	65.1	66.8
J CHAIN STAY LENGTH (CM)	43.5	★	★	★
K BOTTOM BRACKET DROP (CM)	5.1	★	★	★
L BOTTOM BRACKET HEIGHT (CM)	29.5	★	★	★
M FORK RAKE (CM)	4.5	★	★	★
N TRAIL (CM)	7.8	7.2	★	★

BAD BOY

SPECIFICATIONS	SMALL	MEDIUM	LARGE	X-LARGE
A SEAT TUBE LENGTH (CM/IN)	39/15.4	46/18.1	51/20.1	56/22.0
B TOP TUBE HORIZONTAL (CM/IN)	55	57.5	60	62
C TOP TUBE ACTUAL (CM/IN)	52.1/20.5	54.7/21.5	57.3/22.6	59.7/23.5
D HEAD TUBE ANGLE (DEGREES)	70	71	★	★
E SEAT TUBE ANGLE (DEGREES)	74.5	73.5	73	72.5
F STANDOVER AT TOP TUBE MIDPOINT (CM/IN)	73.9	78.2	81.4	84.5
G HEAD TUBE LENGTH (CM/IN)	13	15	17	19
H WHEELBASE (CM/IN)	104.4	105.8	108.1	109.8
I FRONT CENTER (CM/IN)	61.4	62.8	65.1	66.8
J CHAIN STAY LENGTH (CM/IN)	43.5	★	★	★
K BOTTOM BRACKET DROP (CM/IN)	5.1	★	★	★
L BOTTOM BRACKET HEIGHT (CM/IN)	73.9	78.2	81.4	84.5
M FORK RAKE (CM/IN)	4.5	★	★	★
N TRAIL (CM/IN)	7.8	7.2	★	★

HOOLIGAN

SPECIFICATIONS	ONE SIZE
A SEAT TUBE LENGTH (CM/IN)	35/14.6
B TOP TUBE HORIZONTAL (CM/IN)	58.0
C TOP TUBE ACTUAL (CM/IN)	54.7/21.5
D HEAD TUBE ANGLE (DEGREES)	70
E SEAT TUBE ANGLE (DEGREES)	73
F STANDOVER AT TOP TUBE MIDPOINT (CM/IN)	60
G HEAD TUBE LENGTH (CM/IN)	17.1
H WHEELBASE (CM/IN)	106
I FRONT CENTER (CM/IN)	66.2
J CHAIN STAY LENGTH (CM/IN)	40
K BOTTOM BRACKET DROP (CM/IN)	3.6
L BOTTOM BRACKET HEIGHT (CM/IN)	30.5
M FORK RAKE (CM/IN)	4.5
N TRAIL (CM/IN)	2.6

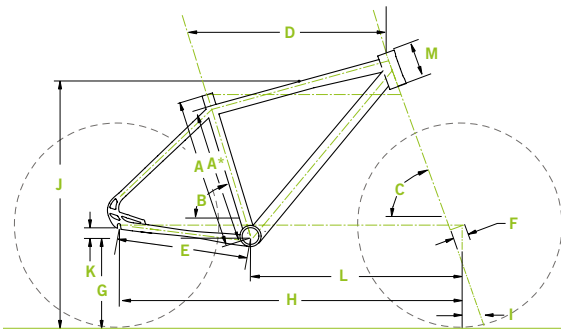

QUICK CARBON

SPECIFICATIONS	SMALL	MEDIUM	LARGE	X-LARGE	JUMBO
WHEEL SIZE	-	-	-	-	-
A* MEASURED SIZE (CM/IN)*	38.5/15.2	41/16.1	46/18.1	51/20.1	57/22.4
B SEAT TUBE ANGLE	75	76	74.5	73	72.5
C HEAD TUBE ANGLE	71	71	71.5	72	72.5
D HORIZONTAL TOP TUBE LENGTH (CM)	53.5	53.5	56	58.5	62
E CHAIN STAY LENGTH (CM)	43	★	★	★	★
F FORK RAKE (CM)	5.0	★	★	★	★
G BOTTOM BRACKET HEIGHT (CM)	27.4	★	★	★	★
H WHEELBASE (CM)	101.4	102.3	103.9	104.8	107.5
I TRAIL (CM)	6.6	6.5	6.2	5.9	5.6
J STANDOVER HEIGHT (CM)	73.8	75.0	78.7	82.8	87.0
K BOTTOM BRACKET DROP (CM)	7.0	★	★	★	★
L FRONT CENTER (CM)	59.5	60.4	61.9	62.8	65.4
M HEAD TUBE LENGTH (CM)	14	13	16	19	22

QUICK SL AND QUICK

SPECIFICATIONS	X-SMALL	SMALL	MEDIUM	LARGE	X-LARGE	JUMBO
WHEEL SIZE	26"	700C	700C	700C	700C	700C
A* MEASURED SIZE (CM/IN)*	32.0/12.6	38.5/15.2	41.0/16.1	46.0/18.1	51.0/20.1	57.0/22.4
B SEAT TUBE ANGLE	76	75	75	74.5	73	72.5
C HEAD TUBE ANGLE	70.5	70.5	70.5	71	71.5	72
D HORIZONTAL TOP TUBE LENGTH (CM)	50.5	535	54.5	56	58.5	62
E CHAIN STAY LENGTH (CM)	43.5	★	★	★	★	★
F FORK RAKE (CM)	5	★	★	★	★	★
G BOTTOM BRACKET HEIGHT (CM)	27.4	★	★	★	★	★
H WHEELBASE (CM)	100.5	102.4	103.7	104.7	105.7	108.4
I TRAIL (CM)	6.2	6.9	6.9	6.6	6.2	5.9
J STANDOVER HEIGHT (CM)	68.9	74.5	75.9	79.3	83.1	87.3
K BOTTOM BRACKET DROP (CM)	5.1	7.0	★	★	★	★
L FRONT CENTER (CM)	57.5	60.0	61.1	62.2	63.2	65.9
M HEAD TUBE LENGTH (CM)	14	14	15	17	20	23

★ Indicates same as previous

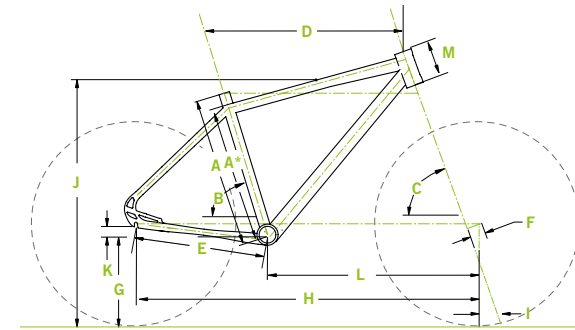

SPECIFICATIONS	SMALL	MEDIUM	LARGE	X-LARGE	JUMBO
A* MEASURED SIZE (CM/IN)*	40.2/15.8	44.2/17.4	48.2/19.5	52.2/20.5	56.2/22.1
B SEAT TUBE ANGLE	74	73.5	73	73	72.5
C HEAD TUBE ANGLE	69	69	70	70.5	71.5
D HORIZONTAL TOP TUBE LENGTH (CM)	54	55	56.5	58	60.5
E CHAIN STAY LENGTH (CM)	45	H	H	H	H
F FORK RAKE (CM)	4.5	H	H	H	H
G BOTTOM BRACKET HEIGHT (CM)	28.0	H	H	H	H
H WHEELBASE (CM)	104.9	105.8	106.2	107.5	108.6
I TRAIL (CM)	8.5	8.5	7.8	7.5	6.9
J STANDOVER HEIGHT (CM)	76.1	79.2	82.2	85.0	87.4
J STANDOVER HEIGHT (CM) HEADSHOK	75.3	77.9	80.0	82.4	85.0
K BOTTOM BRACKET DROP (CM)	6.7	H	H	H	H
L FRONT CENTER (CM)	60.7	61.6	62.1	63.3	64.5
M HEAD TUBE LENGTH (CM) HEADSHOK	11.4	H	H	H	H
M HEAD TUBE LENGTH (CM)	14	15	16	17	18

QUICK CX HEADSHOK AND QUICK CX

ADVENTURE

SPECIFICATIONS	SMALL	MEDIUM	LARGE	X-LARGE	JUMBO
A SEAT TUBE LENGTH OVERALL (CM/IN)	35.6/14.0	40.6/16.0	45.7/18.0	53.3/21.0	61.0/24.0
B SEAT TUBE ANGLE	70	★	★	★	★
C HEAD TUBE ANGLE	69	★	★	★	★
D HORIZONTAL TOP TUBE LENGTH (CM)	56.5	57.2	58	59	60
E CHAIN STAY LENGTH (CM)	46.5	★	★	★	★
F FORK RAKE (CM)	4.5	★	★	★	★
G BOTTOM BRACKET HEIGHT (CM)	28.0	★	★	★	★
H WHEELBASE (CM)	105.4	106.2	107.1	108.2	109.4
I TRAIL (CM)	8.5	★	★	★	★
J STANDOVER HEIGHT (CM)	70	73.2	77.2	82.2	86.3
K BOTTOM BRACKET DROP (CM)	6.8	★	★	★	★
L FRONT CENTER (CM)	59.8	60.6	61.4	62.3	63.7
M HEAD TUBE LENGTH (CM)	13.6	13.6	15.6	17.1	17.1

ADVENTURE 26"

SPECIFICATIONS	SMALL	MEDIUM	LARGE	X-LARGE	JUMBO
A SEAT TUBE LENGTH OVERALL (CM/IN)	35.6/14.0	40.6/16.0	45.7/18.0	53.3/21.0	61.0/24.0
B SEAT TUBE ANGLE	70	★	★	★	★
C HEAD TUBE ANGLE	69	★	★	★	★
D HORIZONTAL TOP TUBE LENGTH (CM)	55	55.7	56.5	58	59.5
E CHAIN STAY LENGTH (CM)	45.7	★	★	★	★
F FORK RAKE (CM)	4.5	★	★	★	★
G BOTTOM BRACKET HEIGHT (CM)	30.3	★	★	★	★
H WHEELBASE (CM)	104.2	105.0	105.9	107.6	109.2
I TRAIL (CM)	8.5	★	★	★	★
J STANDOVER HEIGHT (CM)	70.8	73.9	77.8	82.7	86.7
K BOTTOM BRACKET DROP (CM)	4.5	★	★	★	★
L FRONT CENTER (CM)	59.8	60.6	61.4	62.3	63.7
M HEAD TUBE LENGTH (CM)	13.6	13.6	15.6	17.1	17.1

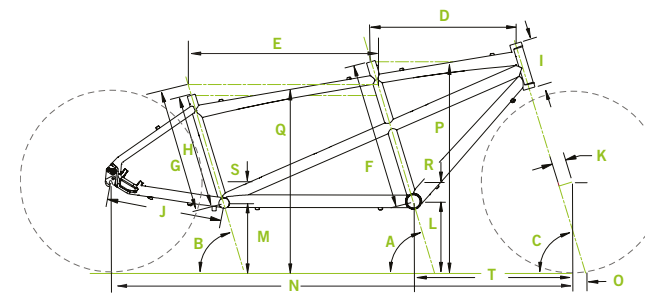

SPECIFICATIONS	M/S	L/S	X/S	J/M
A FRONT SEAT TUBE ANGLE (DEGREES)	73	★	★	★
B REAR SEAT TUBE ANGLE (DEGREES)	73	★	★	★
C HEAD TUBE ANGLE (DEGREES)	73	★	★	★
D HORIZONTAL FRONT TOP TUBE LENGTH (IN/CM)	21.5/54.5	22.0/56.0	22.6/57.5	23.6/60.0
E HORIZONTAL REAR TOP TUBE LENGTH (IN/CM)	28.6/72.6	★	★	29.1/73.9
F FRONT SEAT TUBE OVERALL LENGTH (IN/CM)	19.0/48.3	20.0/50.8	22.0/55.9	23.0/58.4
G REAR SEAT TUBE OVERALL LENGTH (IN/CM)	17.0/43.2	★	★	19.0/48.3
H REAR SEAT TUBE MEASURED LENGTH (IN/CM)	15.6/39.7	15.6/39.7	17.0/43.2	19.0/48.3
I HEAD TUBE LENGTH (IN/CM)	5.9/15.0	6.5/16.5	7.1/18.0	7.9/20.0
J CHAIN STAY LENGTH (IN/CM)	17.4/44.2	★	★	★
K FORK RAKE (IN/CM)	2.1/5.3	★	★	★
L FRONT BOTTOM BRACKET HEIGHT (IN/CM)	10.8/27.4	★	★	★
M REAR BOTTOM BRACKET HEIGHT (IN/CM)	10.5/26.7	★	★	★
N WHEELBASE (IN/CM)	68.4/173.6	69.0/175.1	69.5/176.6	71.0/180.4
O TRAIL (IN/CM)	2.0/5.1	★	★	★
P FRONT STANDOVER AT TOP TUBE MIDPOINT (IN/CM)	28.2/71.7	30.6/77.7	31.6/80.3	32.5/82.6
Q REAR STANDOVER AT TOP TUBE MIDPOINT (IN/CM)	25.4/64.6	26.3/66.8	27.6/70.2	29.5/74.0
R FRONT BOTTOM BRACKET DROP (IN/CM)	2.9/7.4	★	★	★
S REAR BOTTOM BRACKET DROP (IN/CM)	3.2/8.1	★	★	★
T FRONT CENTER DISTANCE (IN/CM)	22.9/58.3	23.5/59.7	24.1/61.2	25.1/63.7